



## FLO-DRI Filters

# G25, M-25 & M-25V Series

## Installation, Maintenance Instructions, & Parts List



**WARNING.** Improper installation adjustment, alteration, excessive vibration, service, or maintenance can cause property damage, injury or death. Read the installation, operating and maintenance instructions thoroughly before installing, operating or servicing this equipment.

### Special Notes

The following special notices highlight important information in the installation, operation and maintenance sections.



CAUTION

This symbol indicates a potentially hazardous situation, which, if not avoided, can result in personal injury or damage to the equipment.



CAUTION

This symbol indicates a potentially hazardous situation, which, if not avoided, may be a shock hazard.



WARNING

This symbol indicates an imminently hazardous situation, which, if not avoided, could result in death or serious injury.

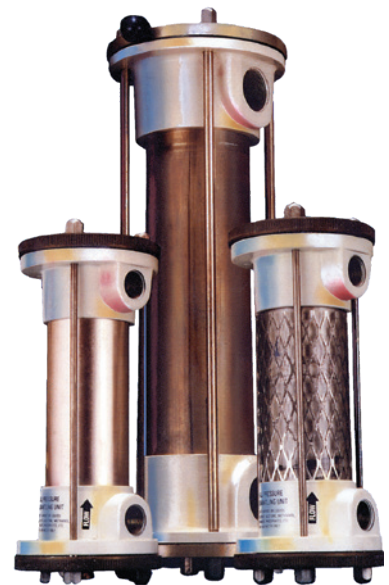

# TABLE OF CONTENTS

A. Filter Maintenance Instructions	3
B. To Change Flo-Dri Cartridges	3
C. Filter Installation Instructions	4
D. Cartridge Media	5
D.1 Natural Gas.....	5
D.2 Compressed Air Cartridge Media.....	5
E. Parts List	5
F. Change-out Schedule for Flo-Dri	6
G. To Order	6

## A. FILTER MAINTENANCE INSTRUCTIONS

1. The following simple maintenance procedures will ensure maximum FLO-DRI filtering efficiency and a longer filter life.
2. FLO-DRI cartridges should be examined frequently until a pattern of usage is established.
3. Failure to replace cartridges in an expedient fashion may result in excessive pressure drop and the possibility of contaminant carry over. Refer to the FLO-DRI Cartridge Change-Out Calculator available on Thermon's website for recommended change out schedules. This calculator allows the user to determine an accurate cartridge replacement schedule based on their specific application. If the calculator is unavailable, replace cartridges every 30 days or when the cartridge appears to be contaminated.
4. Do not subject the unit to vapours or liquids from synthetic solvents, acetone, methanol, esters, lacquer thinners, phosphates, etc.

## B. TO CHANGE FLO-DRI CARTRIDGES



**WARNING.** Never replace filter cartridge when the unit is under pressure. Always follow safe work procedures when working with high pressure.

1. Close inlet, wait for unit to vent, then close the outlet isolation valve to the FLO-DRI filter.
2. To vent filter, open drain cock. Make certain filter is COMPLETELY VENTED and under NO pressure prior to removing the top end cap.
3. To remove the end cap: depress, turn counter clockwise and pull out. DO NOT LOOSEN CASTLE NUTS.
4. Inspect filter media. Replace when completely saturated, or earlier.



**WARNING.** It is essential to positively confirm close of top cap prior to re-pressurizing system.

5. Insert two new FLO-DRI cartridges (sewn end down) into the filter unit.
6. Replace end cap, close drain cock and open isolation valves before returning FLO-DRI unit to service.



**WARNING.** Do not reuse contaminated media.



G-25/M-25

M-25V

Figure 1

## C. FILTER INSTALLATION INSTRUCTIONS

1. For maximum efficiency, FLO-DRI unit should be installed as indicated in Figure 2.
2. Install in a vertical position only.
3. Tighten fittings into casting 6.25 to 6.75 turns. Do not over-tighten threaded connections. This may lead to thread damage or possible cracking of the casting.
4. Ensure flow direction is as indicated on the unit.
5. Installation of drain leg is highly recommended.

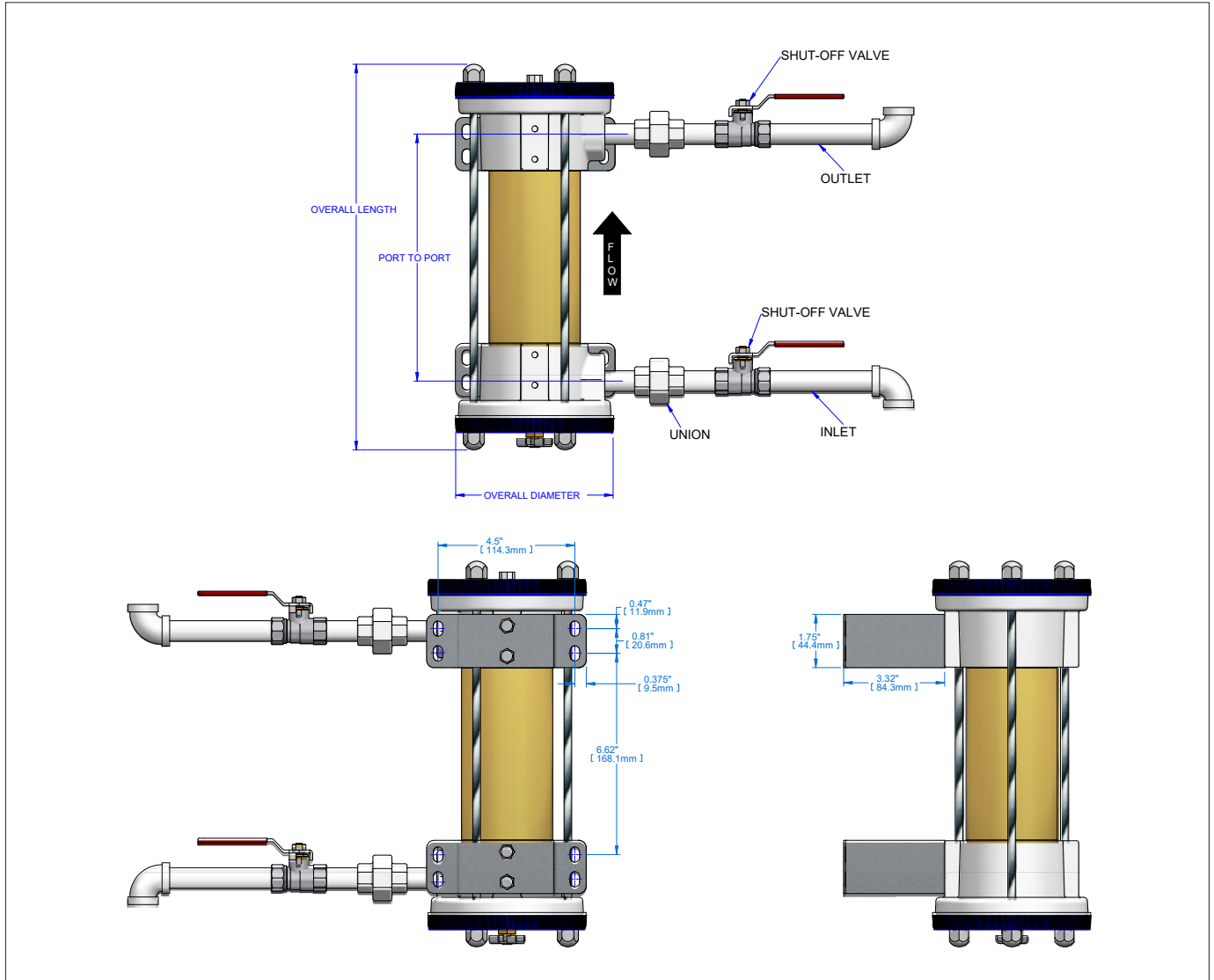

Figure 2 – G-25, M-25, and M-25V Assembly Diagram

Table 1 – Scrubbing System

Scrubbing System	Model No.	PSIG	No. of Cartridges	Overall Length		Overall Diameter		Port to Port		Pipe Size NPT	Bed Cubic in <sup>3</sup>	Cartridge Media Part No.
				in	mm	in	mm	in	mm			
Natural Gas	FLODRI-G25A	250	2	12.88	327	5.25	133	8.13	206	3/4	30.78	FLODRI-25AA
												FLODRI-25AC
												FLODRI-25MS
Compressed Air	FLODRI-M25V	125	2	12.88	327	5.25	133	8.13	206	3/4	30.78	FLODRI-25R
	FLODRI-M25A	250										

## D. CARTRIDGE MEDIA

### D.1 Natural Gas

AA - Moisture Removal

AC - Odor Removal

MS - H<sub>2</sub>S & Moisture Removal

### D.2 Compressed Air Cartridge Media

R - Moisture, Oil and Heavy Liquids Removal, Air Purifier

## E. PARTS LIST

Table 2 – G-25, M-25 & M-25V Parts List

Item	No. Req.	Part No.	Description
A	1	–	Barrel
B	3	–	Tie rod
C	2	–	End cap
D	2	10377	Perforated disc, 25 Series
E	1	10296	Screen, 25 Series, 304SS
F	1	10376	Spring, 25 Series, SST
G	2	10282	O-Ring, End cap, 25 Series, Buna
H	2	12639	O-Ring, Probe, 25 Series, Buna
I	2	–	O-Ring, Body, 25 Series, Buna
J	1	–	Plug, 1/8" Galvanized hex head
K	1	–	Drain cock, Assembly, 1/8 NPT
L	2	–	FLO-DRI cartridge
M	1	10378	Membrane, 25 Series 2" X 0.100" Polyester
N	1	10368	Snap ring, 25 Series, SST
O	2	–	Body

Table 3 – Replacement FLODRI-MTG25

No. Req.	Part No.	Description
2	12426	Bracket, Mounting G25 Scrubber
4	7597	Bolt, 1/4-20 UNC X 1/2" HEX SST
4	A10686-34	1/4" 18-8 Split Lock 304SS
4	9070	Washer, Flat 1/4" 18-8 304SS

Table 4 – Replacement FLODRI-ORING 25 Kit

Item	No. Req.	Part No.	Description
G	2	10282	O-Ring, End cap Lower, 25 Series, Buna
H	2	12639	O-Ring, Probe, 25 Series, Buna
M	1	10378	Membrane, 25 Series 2" X 0.100" Polyester
-	1	10347	O-Ring lube, 6 gram packet

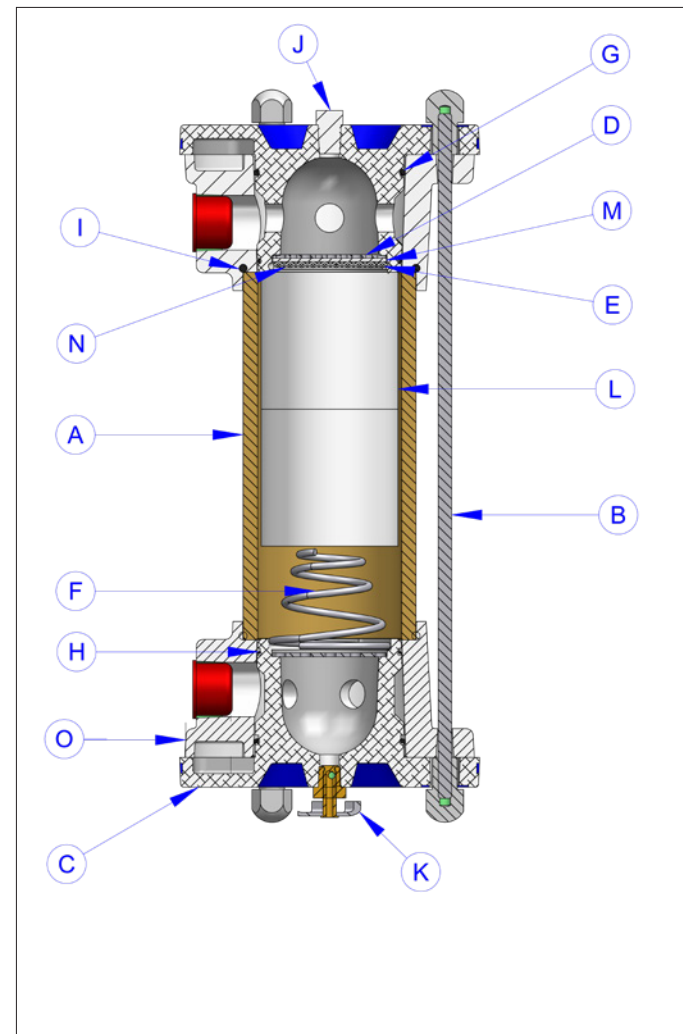

Figure 3 – FLO-DRI cross section view

## F. CHANGE-OUT SCHEDULE FOR FLO-DRI

Table 5, page 6 shows cartridge change-out frequencies in days for each model heater and gas scrubber for H<sub>2</sub>S and moisture.

To determine the cartridge change-out frequency in days for other H<sub>2</sub>S moisture concentrations, use the formulas provided in the examples.

Table 5 – Flo-Dri Cartridge Change Schedule in Days

WX Series	Rating (Btu/hr)	Sour Gas H <sub>2</sub> S		Moisture (50ppm)	
		FloDri-10MS Days	FloDri-25MS Days	FloDri-10MS Days	FloDri-25MS Days
6x6	1,250	450	1,167	360	934
6x12	2,500	225	583	180	467
6x24	5,000	112	291	90	233
8x8	2,222	253	656	202	525
10x12	4,167	135	350	108	280
12x12	5,000	112	291	90	233
12x24	10,000	56	145	45	116
12x36	15,000	37	97	30	77
12x48	20,000	28	72	22	58
12x60	25,000	22	58	18	46
12x72	30,000	18	48	15	38
18x24	15,000	37	97	30	77
18x30	18,750	30	77	24	62
18x36	22,500	25	64	20	51
18x48	30,000	18	48	15	38
18x60	37,500	15	38	12	31
18x72	45,000	12	32	10	25
24x24	20,000	28	72	22	58
24x30	25,000	22	58	18	46
24x36	30,000	18	48	15	38
24x48	40,000	14	36	11	29
24x60	50,000	11	29	9	23
24x72	60,000	9	24	7	19

Example 1: Sour Gas H<sub>2</sub>S

$$\text{Change-out Frequency} = \frac{\text{\# Days (Table 5)}}{\left[ \frac{10 \text{ ppm}}{\text{H}_2\text{S in Gas Supply}} \right]}$$

Your installation has a Cata-Dyne™ heater, model WX 12x24, 10,000 Btu/hr (2.928 kW/hr) natural gas using a model FloDri-10MS cartridge.

- The concentration of H<sub>2</sub>S in your gas supply is 25 ppm.
- The change-out frequency for 10 ppm is 70 days (derived from Table 5).
- COF = 56 days x (10 ppm/25 ppm) = 22 days
- The FloDri-10MS scrubber cartridge should be changed once every 22 days.

Example 2: Moisture

$$\text{Change-out Frequency} = \frac{\text{\# Days (Table 5)}}{\left[ \frac{50 \text{ ppm}}{\text{Moisture in Gas Supply}} \right]}$$

Your installation has a Cata-Dyne™ heater, model WX 12x24, 10,000 Btu/hr (2.928 kW/hr) natural gas using a model FloDri-10MS cartridge.

- The concentration of H<sub>2</sub>S in your gas supply is 25 ppm.
- The change-out frequency for 50 ppm is 45 days (derived from Table 5).
- COF = 45 days x (50 ppm/25 ppm) = 90 days
- The FloDri-10MS scrubber cartridge should be changed once every 90 days.

## G. TO ORDER

Model number and cartridge media part number.

# NOTES

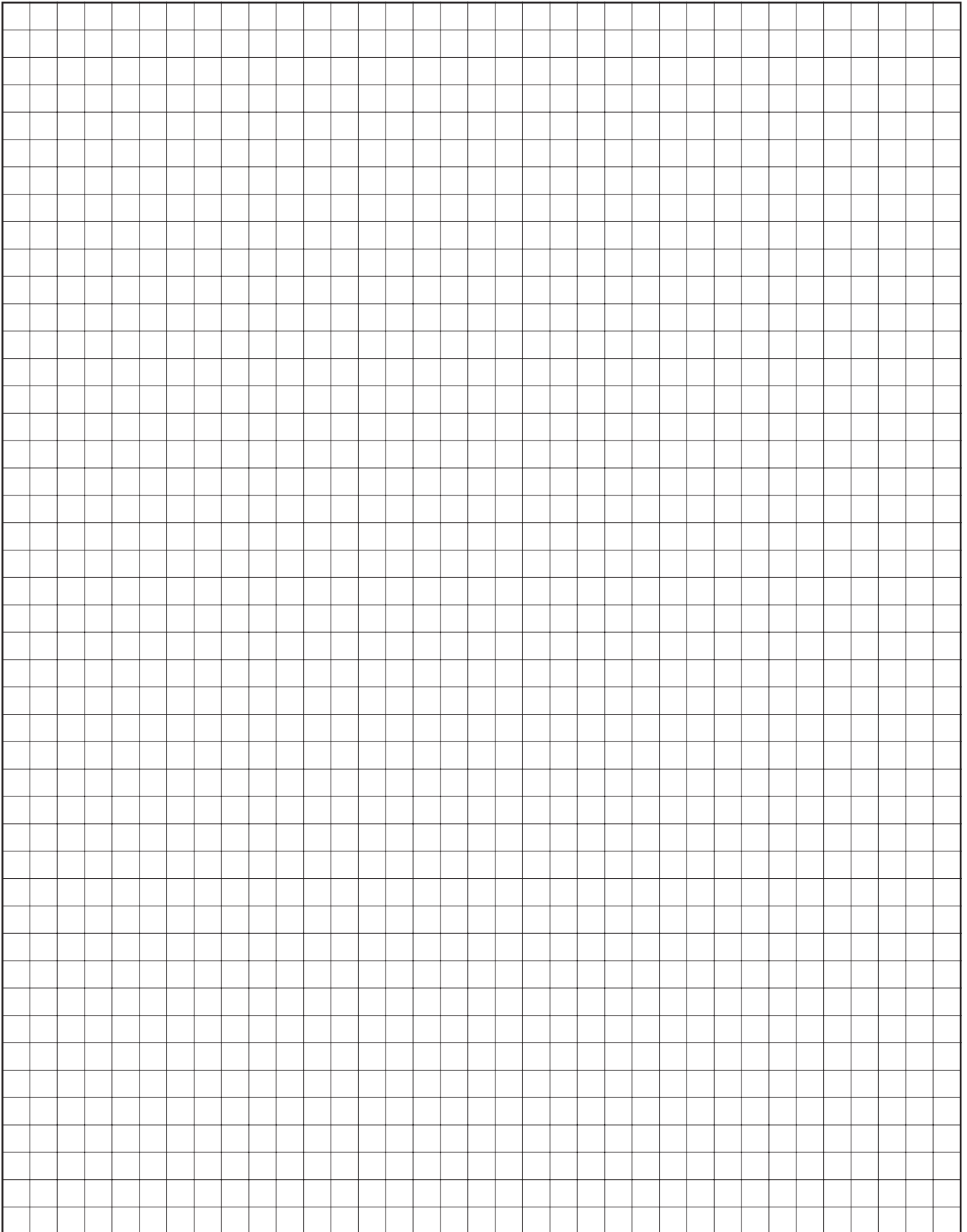



## PLEASE ADHERE TO INSTRUCTIONS IN THIS MANUAL

Failure to do so may be dangerous and may void certain provisions of your warranty.

For further assistance, please call 24hr hotline: 1.800.661.8529 (U.S.A. and Canada)  
Please have model and serial numbers available before calling.

**WARRANTY:** Under normal use the Company warrants to the purchaser that defects in material or workmanship will be repaired or replaced without charge for a period of 18 months from date of shipment, or 12 months from the start date of operation, whichever expires first. Any claim for warranty must be reported to the sales office where the product was purchased for authorized repair or replacement within the terms of this warranty.

Subject to State or Provincial law to the contrary, the Company will not be responsible for any expense for installation, removal from service, transportation, or damages of any type whatsoever, including damages arising from lack of use, business interruptions, or incidental or consequential damages.

The Company cannot anticipate or control the conditions of product usage and therefore accepts no responsibility for the safe application and suitability of its products when used alone or in combination with other products. Tests for the safe application and suitability of the products are the sole responsibility of the user.

This warranty will be void if, in the judgment of the Company, the damage, failure or defect is the result of:

- Vibration, radiation, erosion, corrosion, process contamination, abnormal process conditions, temperature and pressures, unusual surges or pulsation, fouling, ordinary wear and tear, lack of maintenance, incorrectly applied utilities such as voltage, air, gas, water, and others or any combination of the aforementioned causes not specifically allowed for in the design conditions or,
- Any act or omission by the Purchaser, its agents, servants or independent contractors which for greater certainty, but not so as to limit the generality of the foregoing, includes physical, chemical or mechanical abuse, accident, improper installation of the product, improper storage and handling of the product, improper application or the misalignment of parts.

No warranty applies to paint finishes except for manufacturing defects apparent within 30 days from the date of installation.

The Company neither assumes nor authorizes any person to assume for it any other obligation or liability in connection with the product(s).

The Purchaser agrees that all warranty work required after the initial commissioning of the product will be provided only if the Company has been paid by the Purchaser in full accordance with the terms and conditions of the contract.

The Purchaser agrees that the Company makes no warranty or guarantee, express, implied or statutory, (including any warranty of merchantability or warranty of fitness for a particular purpose) written or oral, of the Article or incidental labour, except as is expressed or contained in the agreement herein.

**LIABILITY:** Technical data contained in the catalog or on the website is subject to change without notice. The Company reserves the right to make dimensional and other design changes as required. The Purchaser acknowledges the Company shall not be obligated to modify those articles manufactured before the formulation of the changes in design or improvements of the products by the Company.

The Company shall not be liable to compensate or indemnify the Purchaser, end user or any other party against any actions, claims, liabilities, injury, loss, loss of use, loss of business, damages, indirect or consequential damages, demands, penalties, fines, expenses (including legal expenses), costs, obligations and causes of action of any kind arising wholly or partly from negligence or omission of the user or the misuse, incorrect application, unsafe application, incorrect storage and handling, incorrect installation, lack of maintenance, improper maintenance or improper operation of products furnished by the Company.

Edmonton  
1-780-466-3178  
F 780-468-5904  
5918 Roper Road  
Alberta, Canada T6B 3E1

Oakville  
1-800-410-3131  
1-905-829-4422  
F 905-829-4430

Orillia  
1-877-325-3473  
1-705-325-3473  
F 705-325-2106

Houston  
1-800-654-2583  
1-713-433-2600  
F 713-433-4541

Denver  
1-855-244-3128  
1-303-979-7339  
F 303-979-7350