

Fan-Forced Enclosure Heater - PH



Application

Caloritech™ PH fan-forced enclosure heaters are designed to control the environment within enclosures by maintaining a stable temperature. Effects of low temperatures such as corrosion, freezing or condensation will adversely affect the components inside control panels. The Caloritech™ PH enclosure heater will provide an optimal performance environment for the critical components contained within the control panel.

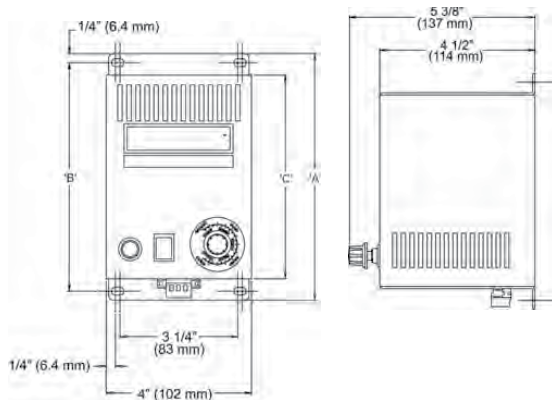

Figure 1

Table 1 – Dimensions

Catalog No.	Dimensions					
	A		B		C	
	in	mm	in	mm	in	mm
PH125/PH200	5.500	140	5.000	127	4.125	105
PH400/PH800	7.500	191	7.000	178	6.188	157

Features

- cCSA_{US} approved
- cUL_{US} certified
- Light weight unit
- Low maintenance
- Aluminum alloy outer casing
- Externally adjustable thermostat 0°F to 100°F (-18°C to 38°C)
- Pilot light for “heat-on” indication
- High temperature safety protection
- Fan on/auto switch to prolong motor life
- Terminal strip provides quick installation and accepts both stranded and solid wire
- Optional DIN rail mounts available

Selection

The wattage requirement is determined from a consideration of the surface area, insulation properties of the enclosure or space and the temperature difference between the ambient and the enclosure. For small enclosures (less than 100 ft² (9.3 m²) surface area) conservative values for heat loss areas shown in Table 2, page C4.

Table 2 – Temperature Difference

Watts/ft ² per 10°F	Indoors	Outdoors
Uninsulated	5	7
Insulated (Min. 1”/25 mm)	1	1.2
Watts/m ² per 5.5°C	Indoors	Outdoors
Uninsulated	54	75
Insulated (Min. 2.5 cm)	11	13

Example: To find wattage requirements in an uninsulated enclosure 2' x 3' x 1' (0.61 m x 0.91 m x 0.3 m), which must be held at 40°F (4°C) in a 10°F (-12°C) outdoor ambient. Internal electrical components use 80 watts.

$$\text{Surface Area (ft}^2\text{)} = 2[(2' \times 3') + (2' \times 1') + (3' \times 1')] = 22 \text{ ft}^2$$

$$\begin{aligned} \text{Surface Area (m}^2\text{)} &= 2[(0.61 \text{ m} \times 0.92 \text{ m}) + (0.61 \text{ m} \times 0.3 \text{ m}) \\ &\quad + (0.92 \text{ m} \times 0.3 \text{ m})] \\ &= 2.0404 \text{ m}^2 \end{aligned}$$

Heat Loss: From Table 2, page C4, an uninsulated outdoor enclosure requires 7 watts for each 10°F temperature difference (75 watts for each 5.5°C temperature difference).

$$\text{Temperature Difference (°F)} = 40^\circ\text{F} - 10^\circ\text{F} = 30^\circ\text{F}$$

$$\text{Temperature Difference (°C)} = 4.4^\circ\text{C} - (-12.2^\circ\text{C}) = 16.6^\circ\text{C}$$

$$\text{Wattage Required} = (30^\circ\text{F} \div 10^\circ\text{F}) \times 7 \times 22 \text{ ft}^2 = 462 \text{ watts}$$

Or:

$$\text{Wattage Required} = (16.6^\circ\text{C} \div 5.5^\circ\text{C}) \times 75 \times 2.0404 \text{ m}^2 = 462 \text{ watts}$$

$$\text{Heater Wattage} = \text{Wattage required less component wattage}$$

Or:

$$462 - 80 = 382 \text{ watts}$$

Use one PH400 rated at 400 watts. For enclosures requiring more than 800 watts, two or more PH heaters may be used.

Installation

The Caloritech™ PH fan-forced enclosure heater should be installed in the centre of the cabinet and as low as practicable for the best possible heat dissipation. The optimum efficiency is obtained when the unit is mounted in a vertical position allowing the top air vents to release the heated air in the most effective manner. The control panels should be sealed and free from dust and dirt. Do not install the heaters on wood, cardboard or other flammable panels. Heat sensitive components should not be placed near the heat discharge area. For larger enclosures, two or more heaters may be used.

Table 3 – PH Series Fan-Forced Enclosure Heater

Catalog Number	Watts	Voltage	Hertz	Phase	Weight	
					lbs	kg
PH12511	125	120	60	1	2.2	1.0
PH12531	125	240	60		2.2	1.0
	105	220	50		2.2	1.0
PH20011	200	120	60		2.2	1.0
PH20031	200	240	60		2.2	1.0
	168	220	50		2.2	1.0
PH40011	400	120	60		3.0	1.4
PH40031	400	240	60		3.0	1.4
	336	220	50		3.0	1.4
PH80011	800	120	60		3.0	1.4
PH80031	800	240	60		3.0	1.4
	672	220	50		3.0	1.4