

# Immersion Heaters CX Series

## Installation, Operation, & Maintenance Instructions For CE/ATEX and IECEx Models. Models with Increased Safety (Type eb) Protection Method

### Special Notes



**CAUTION.** This document presents the minimum requirement pertaining to the installation, operation, and maintenance of the respective equipment as required by the manufacturer only. Any additional considerations, including but not limited to any design consideration, in-service inspection, and fitness-for-service assessment for all pressure boundary components to meet any safety principles and local jurisdictional regulatory requirements, shall be the responsibility of the user.



**ELECTRIC SHOCK HAZARD.** All electric heating equipment installations must be performed by qualified personnel in accordance with the local electrical codes and standards and must be effectively grounded to eliminate shock hazard.



**FIRE/EXPLOSION HAZARD FOR EXPLOSIVE ATMOSPHERE HEATERS.**

This heater shall be used with protection controls as follows:

#### Liquid Immersion Applications

- Liquid level control to maintain all the heating elements totally immersed at all times, in conjunction with temperature controls to limit the liquid temperature below the maximum allowable process design temperature.
- Terminal box internal surface temperature control to limit the surface temperature of the terminal box
- Heater flange surface temperature control to limit the surface temperature of the flange.
- Heating elements sheath temperature controls to limit to the maximum allowable sheath design temperature
- Earth fault or earth leakage current protection device to protect against arcing and sparking during an earth fault.

#### Gaseous and/or vapour phase immersion applications

- Heating elements sheath temperature controls to limit to the maximum allowable sheath design temperature.
- Terminal box internal surface temperature control to limit the surface temperature of the terminal box
- Heater flange surface temperature control to limit the surface temperature of the flange.
- Earth fault or earth leakage current protection device to protect against arcing and sparking during an earth fault.





**Fire/Explosion Hazard.** Do not exceed the ratings of the flange as listed in ANSI B16.5. In case of code stamped or registered heater, do not exceed the rating as stated in the data report and/or registration documents. Do not operate the heater in the presence of combustible gases, vapours, dusts or fibres unless the heater is specifically marked for the hazardous location and heater operating temperature does not exceed the temperature code rating. Corrosion of the sheath could result in a ground fault which, depending upon the fluid being heated, could cause a fire or an explosion.



**Fire Hazard.** If a thermostat is provided, it is designed for temperature control service only. Since the thermostat does not fail safe, it should not be used for temperature limiting duty. Wiring to this device is the users' responsibility.

Heaters are capable of developing high temperatures, therefore extreme care should be taken to:

- a. Use explosion-proof terminal enclosures in explosive atmospheres.
- b. Maintain distance between heater and combustible materials.

The heater must be installed and operated in accordance with the following specific conditions of use:

1. The heater shall be installed with electrical safety devices as described in the Installation, Operating and Maintenance manual and in accordance with local codes and standards.
2. It is the user's responsibility to connect the installed temperature sensors to safety devices as defined in IEC 60079-0, that are fail-safe and can only be reset manually. The temperature monitoring circuit shall be set according to the controller set point label on the equipment and used to disconnect the supply when operated.
3. Anti-condensation heater, if used, shall be prevented from operating while the immersion heater is in operation.
4. The temperature classification of the heater is based on the complete immersion of the heater elements in either a fluid or gas. Depending on the use of the heater, a flow or liquid level device must be used to ensure immersion in the process medium. Refer to the Installation, Operating and Maintenance manual for details.
5. The heater must be installed in accordance within the operating parameters taken from the nameplate, caution labels, instruction manual and condition of use documentation.
6. An electrical protection device must be installed to protect against earth related faults in accordance with the Installation, Operating and Maintenance manual.

# TABLE OF CONTENTS

A. Diagrams .....	4
B. Description .....	6
C. Installation .....	7
D. Operation .....	8
E. Maintenance .....	8

# A. DIAGRAMS

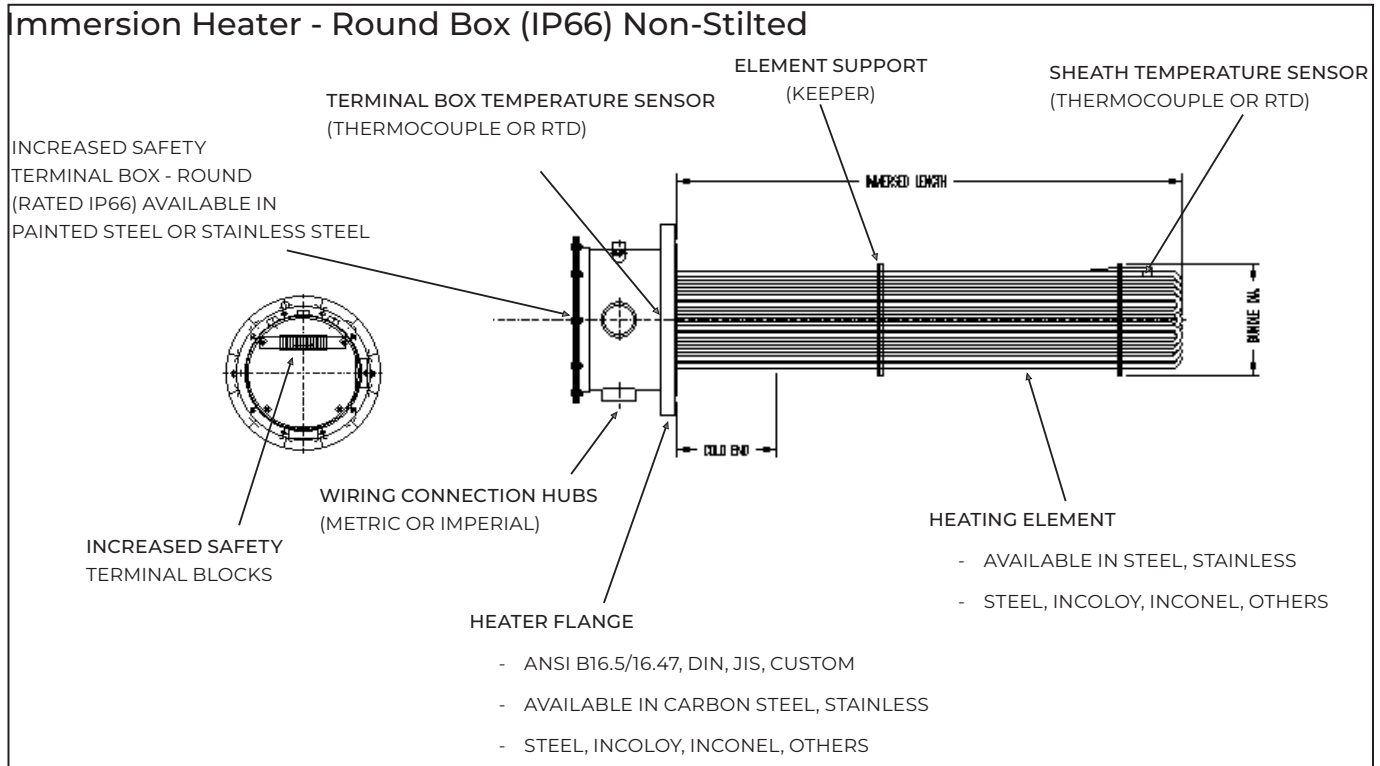

Figure 1

Electrical Ratings: Voltages up to 690 Vac, 1 or 3 PH., Wattages Up To 4,000KW, 50 or 60Hz  
 Ambient Temperature Rating: -60 °C to +80 °C  
 Markings: IECEx Ex eb IIC Gb, T1 to T6  
 ATEX ⚠ II 2 G Ex eb IIC T1 TO T6 Gb  
 Mounting Orientation: Horizontal or Vertical

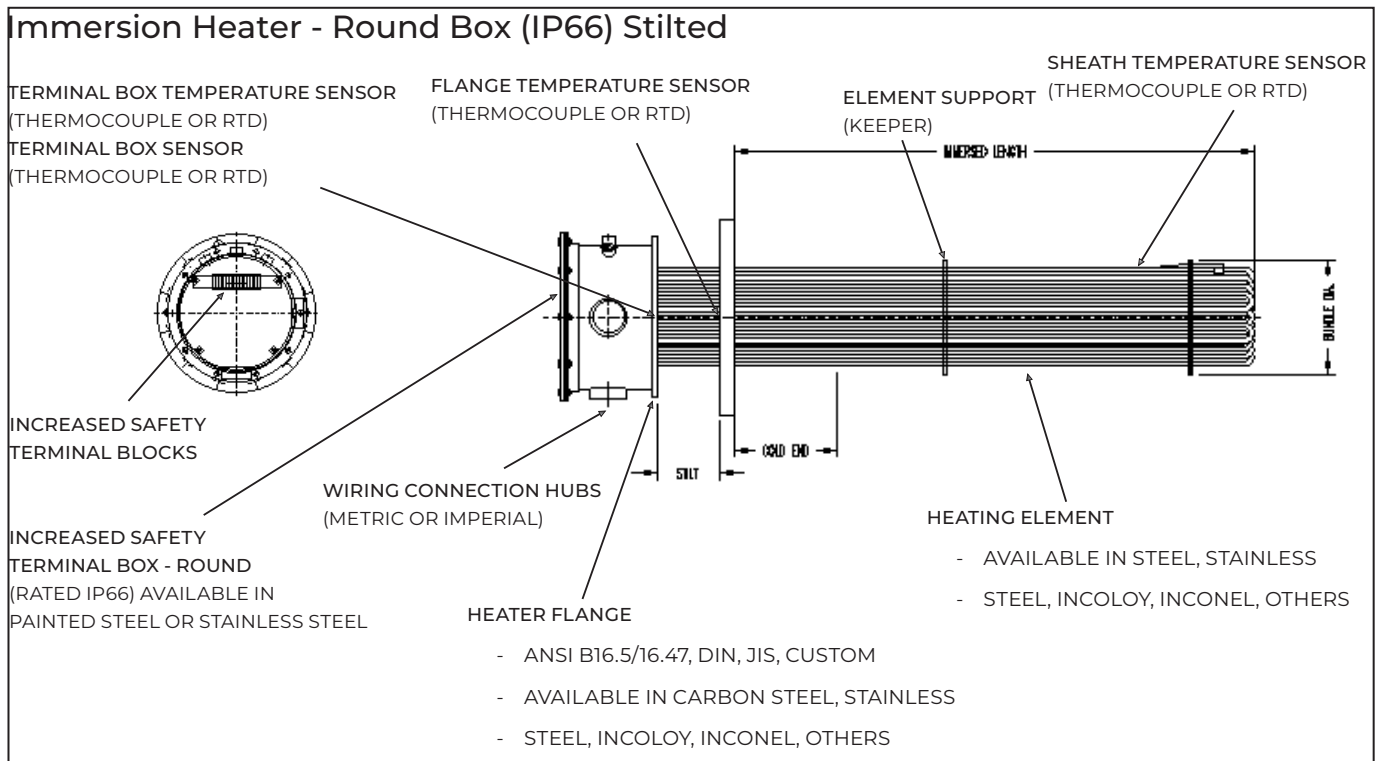
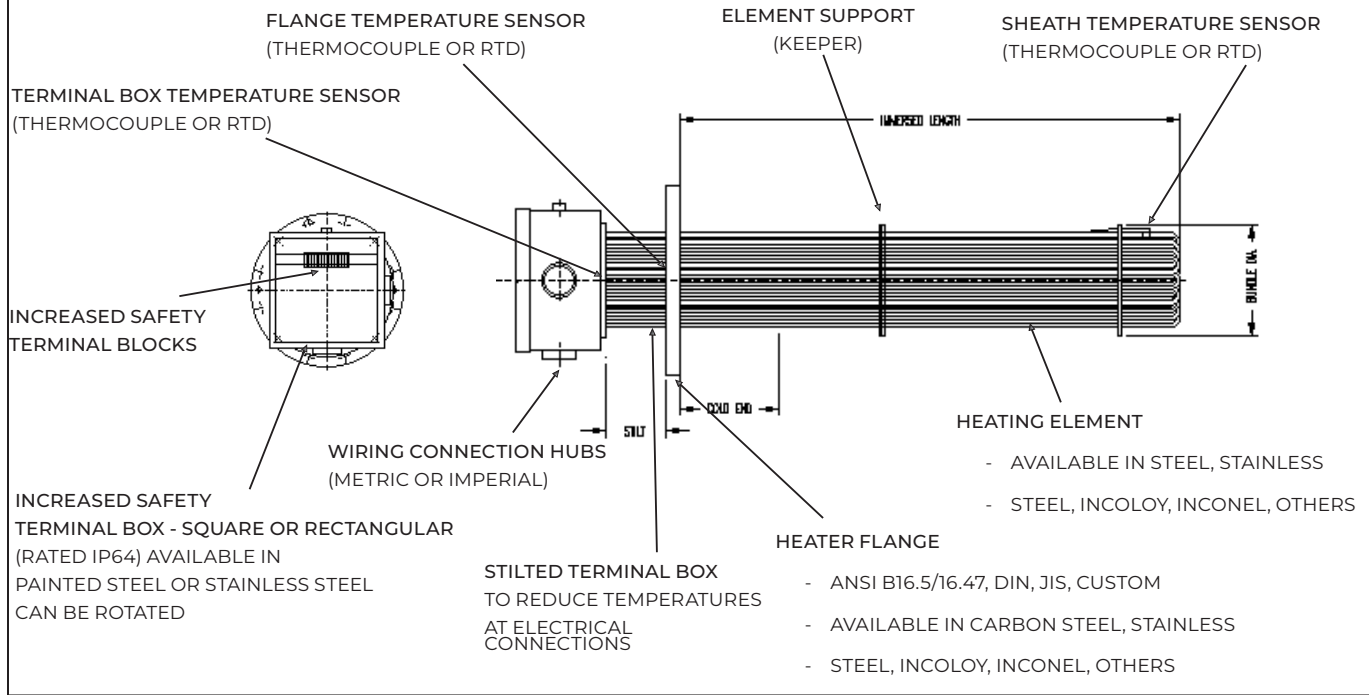

Figure 2

Electrical Ratings: Voltages up to 690 Vac, 1 or 3 PH., Wattages Up To 4,000KW, 50 or 60Hz  
 Ambient Temperature Rating: -60 °C to +80 °C  
 Markings: IECEx Ex eb IIC Gb, T1 to T6  
 ATEX ⚠ II 2 G Ex eb IIC T1 TO T6 Gb  
 Mounting Orientation: Horizontal or Vertical

# Immersion Heater - Square or Rectangular Box (IP64) - Stilted



Electrical Ratings: Voltages up to 690 Vac, 1 or 3 PH., Wattages Up To 4,000KW, 50 OR 60Hz

Ambient Temperature Rating: -60 °C to +80 °C

Markings: IECEx Ex eb IIC Gb, T1 to T6

ATEX II 2 G Ex eb IIC T1 TO T6 Gb

Mounting Orientation: Horizontal or Vertical

Figure 3

## B. DESCRIPTION

1. Immersion heaters for liquid service are designed for operation only while completely immersed in liquids. Never allow the heating elements to be exposed while energized or failure will result.

 **CAUTION** Use the heater only in liquids and at pressures for which it was designed (unless specifically designed for non-liquid applications). Normally copper sheath is recommended in water, steel or alloy sheath in oil, and the appropriate alloy sheath for heating chemical solutions. Check factory for recommendations.

2. In the case of flanged (and some screwplug type) heaters where a gasket seal is required, the gasket surface should be clean and dry before the heater is seated.

 **WARNING** DO NOT insulate over the heater flange, stilted area and terminal enclosure.

3. The terminals must be protected at all times from moisture or vapour. In explosive atmospheres, explosion resistant terminal housings must be used. In outdoor locations, moisture resistant housings are required. It is recommended to use a drip loop to prevent moisture from entering the terminal box via the wire or cable.
4. Protect terminals of heating elements from drippings, condensation, fumes, spray or any other substance which could result in element contamination.
5. When melting solids by direct immersion, a surface vent should be provided to allow gases to escape. Operate the heater on ½ voltage until melted material completely covers the heating elements. Heaters used for this purpose may require special design features. Check factory for recommendations.

6. For  and/or IECEx Certification:

 II 2 G Ex eb IIC T6...T1 Gb

In accordance with:

EN IEC 60079-0:2018      IEC 60079-0:2017  
EN 60079-7:2017      IEC 60079-7:2017

**Caloritech™**  
Engineered Electric Heat  
2721 PLYMOUTH DR. OAKVILLE, ON. CANADA

 2813

 II 2 G

CAT. NO.

PART NO.  TYPE

S.O. NO.  DATE

CSANe 20ATEX3165X  
EX eb IIC T\*\*\* Gb  
IECEX CSA 19.0013X  
Ex eb IIC Gb T\*\*\*

VAC  PH.  KW  Hz

HAZARDOUS LOCATION

CLASS  ZONE  GR.

CLASS  ZONE  TEMP. CODE

IP RATING  \*\*\*\*\*

PROCESS TEMP. MAX.  °C  °F

AMBIENT TEMP. -60° TO 80°C  
-76° TO 176°F

MADE IN CANADA  
THERMON HEATING SYSTEMS, INC.  
www.thermon.com

O      22506-01

## C. INSTALLATION



**CAUTION** Heaters with overtemperature devices require specific installation orientation. Overtemperature devices are required to be installed in accordance with local codes and standards and be designed to de-energize the heater on an overtemperature event.



**Electric Shock Hazard** Disconnect all power before installing or servicing the heater. Failure to do so could result in personal injury and/or property damage. All maintenance and installation should be done by qualified personnel in compliance with local codes.



**Fire or Shock Hazard** Moisture accumulation on the dielectric material of the elements, sheath corrosion or overtemperature on the heaters could cause a fault to ground generating arcing and molten metal. Install proper ground fault protections to prevent personal injury or property damage.



**WARNING** The end user is responsible for the proper integration of the electrical systems, including protections, backups, and controls.



**CAUTION** For explosive atmospheres an approved liquid level and/or temperature limiting control must be used to de-energize in the event of system malfunction. Unless otherwise specified, use supply wire suitable for 90°C min.



**WARNING** Creepage and clearance for electrical connections to the heater must be maintained in accordance with local codes and standards for IECEx and ATEX Increased Safety installations.

1. Unpack and check heater for any damage that may have been caused during shipping.
2. Remove any protective packaging in the screw or flange connecting fitting.
3. Remove any dessicant material in the electrical box.
4. Insert heater into vessel/reservoir and verify that the heating elements are not making contact with the surface of the vessel.
5. Check that all terminal connections are tight.



**CAUTION** Use copper conductors only with sufficient current carrying capacity for the heater circuit load and in accordance with the local electrical code. Check the heater nameplate for minimum conductor temperature rating. Temperature deration factors must be applied for heaters operating above 30°C (86°F).

6. Check supply voltage for compliance with heater nameplate voltage. DO NOT connect the heater to a voltage source other than listed on the heater nameplate.
7. If the heater is immersed in liquid, a level control switch or overtemperature sensing device affixed to the uppermost heating element is required. Check factory for recommendations.
8. If the heater is installed in a pressurized system, a safety relief valve must be used to prevent a hazardous pressure buildup.
9. Horizontal element support bundles may be necessary with an immersed length over 1270 mm (50"). Refer to the heater drawings for details.
10. For flange heaters installed in a pressurized system, proper bolting hardware must be used that is suitable for the pressures and temperatures of the equipment. Use an appropriate gasket for the pressure and temperature; torque the bolts on an even clockwise or counter clockwise pattern. Refer to the heater drawings for details.
11. Heaters with explosion resistant terminal housings must only be used in locations for which the heaters are certified.
  - Check heater nameplate information for approval code.
  - Never energize an explosion resistant heater unless the terminal housing cover is properly tightened.
  - An immersion heater for explosive atmospheres is approved for use only if an approved liquid level control and/or temperature limiting device is used to de-energize the heater under low liquid conditions.
12. On ATEX/CE certified heaters which are being installed in the EU, the installation of heater shall be in accordance with the requirements of the local jurisdiction.
13. Temperature sensors supplied are required to be used with an overtemperature protection device in order to maintain the Temperature Code (T-Code) of the heater.



**WARNING** Do not set the overtemperature protection device above the setpoint indicated on the heater nameplate. Refer to the heater drawings for more information.

14. The heaters must be protected against abnormal earth fault and earth leakage current. Depending on the electrical power system, the following protection device must be installed with the heater:

**TT and TN Systems:**

A residual current protection device with a trip setting not exceeding 100mA. The residual current protection device shall disconnect power supply to the heater when residual current above the trip setting has been detected.

**IT Systems:**

An insulation monitoring device designed to trip when the insulation between any phase of the electrical power supply to ground is less than 50Ω/V.

## D. OPERATION



**RISK OF EXPLOSION** Do not operate heater at voltages higher than the rating specified on the nameplate. Failure to do this will cause elevated temperatures.



**WARNING** Prior to operation an insulation resistance check must be performed. Heater with values less than 500,000 ohms should follow a drying process. Please contact factory for details on procedure if heater is under 500,000 ohms



**FIRE HAZARD** Heater should be submersed in the fluid for proper operation and to avoid element overheating that could result in fire or damage of the heater.



**WARNING** When operating the heaters in a closed system or vessel, system designers must ensure that proper controls are used to maintain the temperature and pressure at normal levels.



**WARNING** Low megohm on heating elements with epoxy or hermetic seals cannot be serviced in the field. Typical resistance values when sealed are 1000 MΩ or greater.

1. Check that all connections are tight.
2. If a thermostat is provided, verify that it is operating properly by cycling it and verifying cutout.
3. Perform an IR test prior to energization and verify that levels are acceptable (500,000 ohms min).
4. Energize the heater and check for signs of hotspots in the electrical connections or vessel.
5. Retorque all bolted fitting connections and all electrical connections after 10 cycles.
6. For heaters installed in a tank, maintain a minimum of 51mm (2") of liquid above the heated portion of the element or element failure may result. Heating elements should be kept above sediment deposits or it may overheat and shorten life expectancy.

## E. MAINTENANCE



**WARNING** Disconnect all power before servicing the heater or heated equipment. Failure to do so could result in personal injury and/or property damage. All maintenance and installation should be done by qualified personnel in compliance with local codes.

1. Heaters stored for prolonged periods may absorb moisture. Using a 500V DC megger (insulation resistance tester) check the value of the insulation resistance to ground for each circuit. Initial readings of over 500,000 ohms to ground are normally acceptable. Should lower readings be observed, check factory for instructions.
2. Periodically check electrical connections for tightness and check wire insulation for any damage and replace if necessary.
3. Remove the immersion heater periodically to inspect for corrosion, sludge build-up and for scale removal. Do not continue to use a heater showing visible signs of damage.



# NOTES

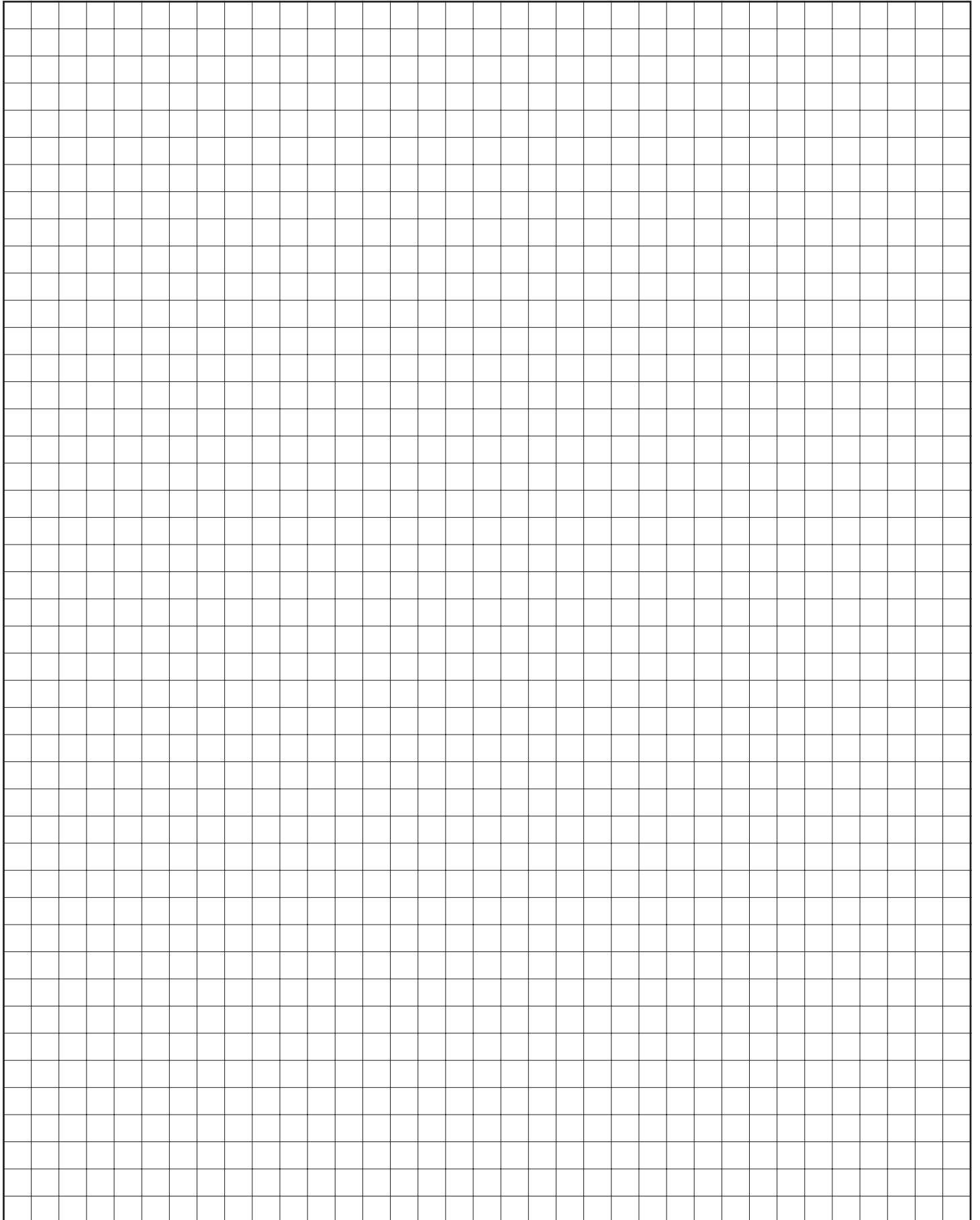

# NOTES

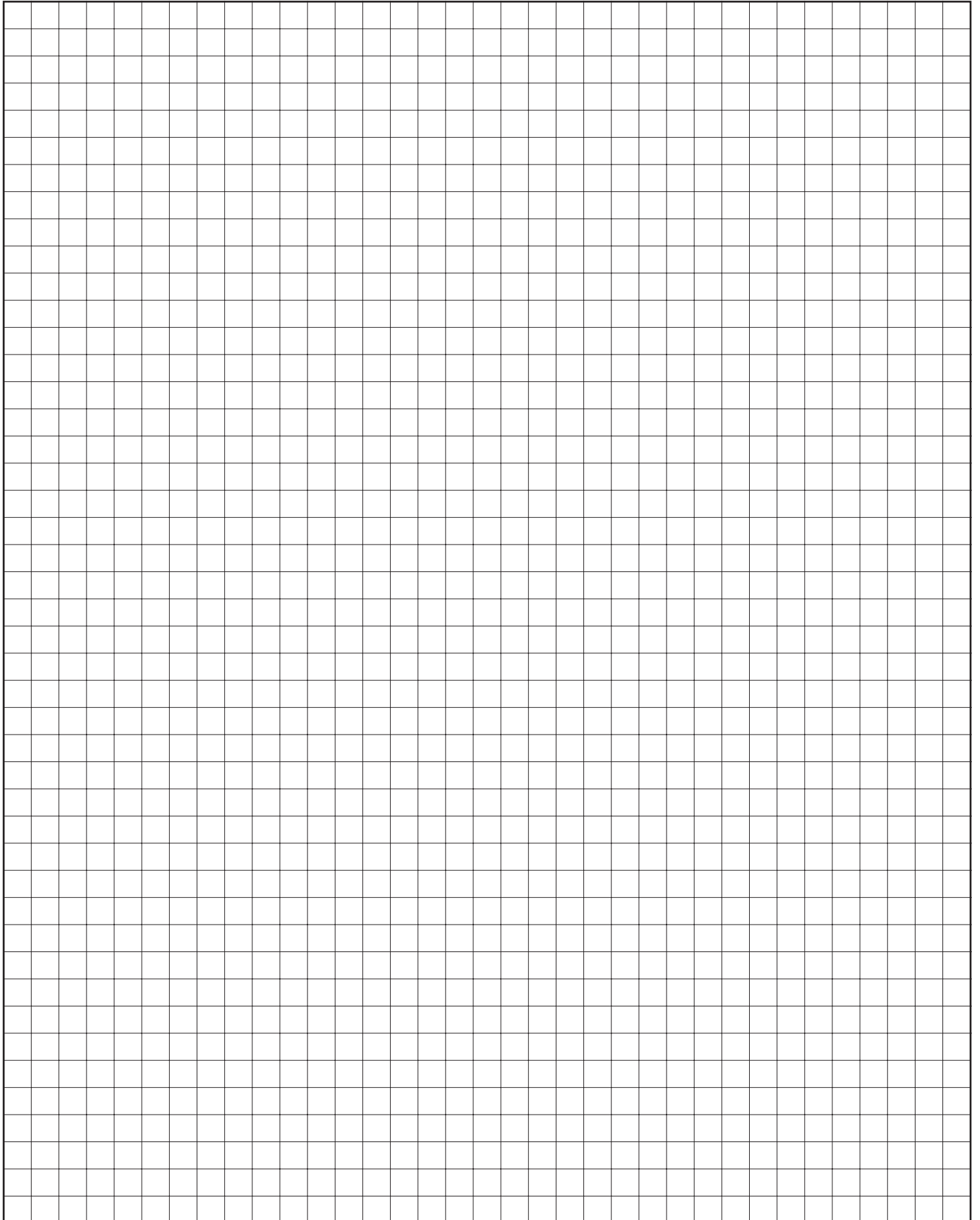

# NOTES

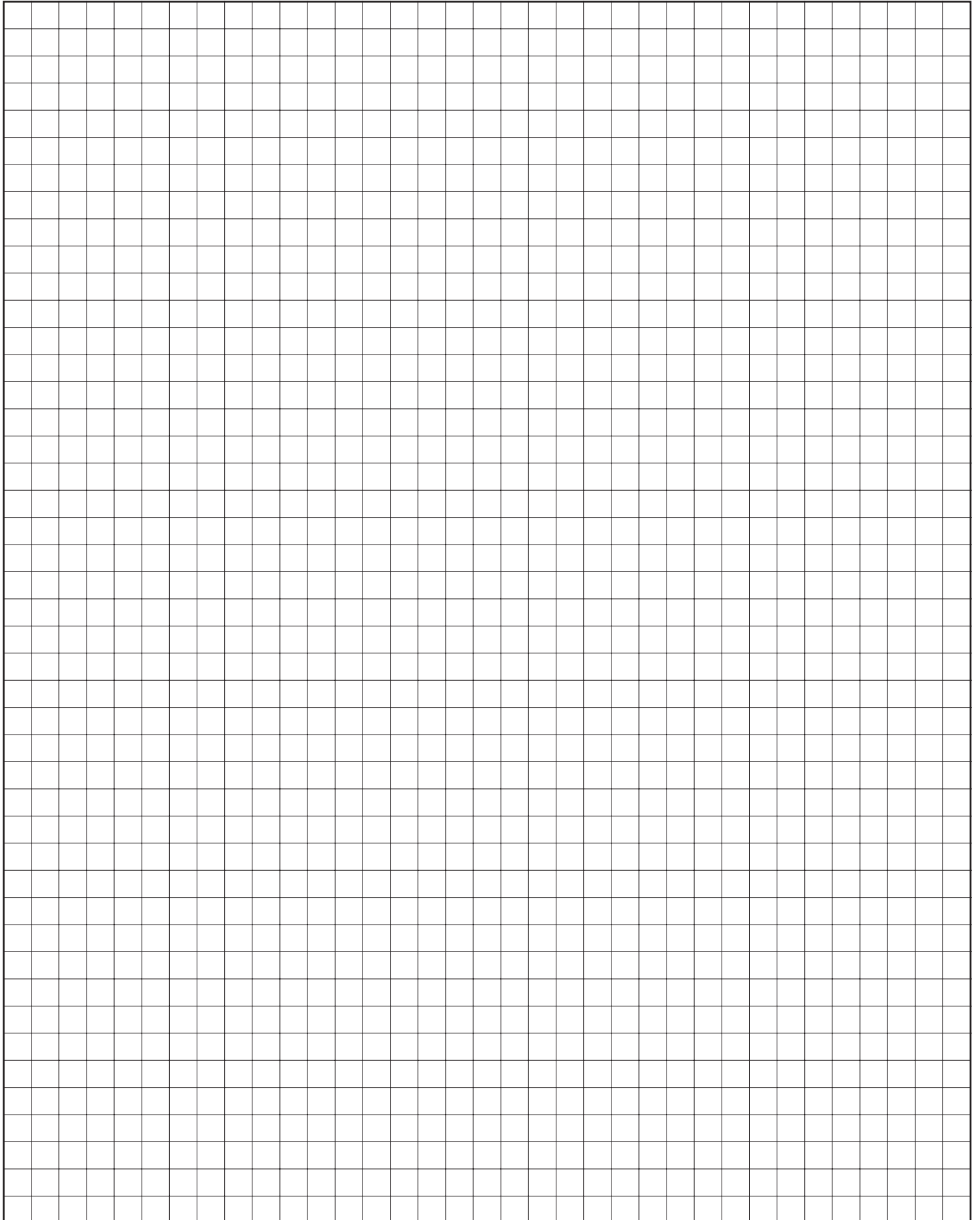



For further assistance, please call 24-hr hotline: 1-877-325-3473 (U.S.A. and Canada)  
Please have model and serial numbers available before calling.

**WARRANTY:** Under normal use the Company warrants to the purchaser that defects in material or workmanship will be repaired or replaced without charge for a period of 18 months from date of shipment, or 12 months from the start date of operation, whichever expires first. Any claim for warranty must be reported to the sales office where the product was purchased for authorized repair or replacement within the terms of this warranty.

Subject to State or Provincial law to the contrary, the Company will not be responsible for any expense for installation, removal from service, transportation, or damages of any type whatsoever, including damages arising from lack of use, business interruptions, or incidental or consequential damages.

The Company cannot anticipate or control the conditions of product usage and therefore accepts no responsibility for the safe application and suitability of its products when used alone or in combination with other products. Tests for the safe application and suitability of the products are the sole responsibility of the user.

This warranty will be void if, in the judgment of the Company, the damage, failure or defect is the result of:

- Vibration, radiation, erosion, corrosion, process contamination, abnormal process conditions, temperature and pressures, unusual surges or pulsation, fouling, ordinary wear and tear, lack of maintenance, incorrectly applied utilities such as voltage, air, gas, water, and others or any combination of the aforementioned causes not specifically allowed for in the design conditions or,
- Any act or omission by the Purchaser, its agents, servants or independent contractors which for greater certainty, but not so as to limit the generality of the foregoing, includes physical, chemical or mechanical abuse, accident, improper installation of the product, improper storage and handling of the product, improper application or the misalignment of parts.

No warranty applies to paint finishes except for manufacturing defects apparent within 30 days from the date of installation.

The Company neither assumes nor authorizes any person to assume for it any other obligation or liability in connection with the product(s).

The Purchaser agrees that all warranty work required after the initial commissioning of the product will be provided only if the Company has been paid by the Purchaser in full accordance with the terms and conditions of the contract.

The Purchaser agrees that the Company makes no warranty or guarantee, express, implied or statutory, (including any warranty of merchantability or warranty of fitness for a particular purpose) written or oral, of the Article or incidental labour, except as is expressed or contained in the agreement herein.

**LIABILITY:** Technical data contained in the catalog or on the website is subject to change without notice. The Company reserves the right to make dimensional and other design changes as required. The Purchaser acknowledges the Company shall not be obligated to modify those articles manufactured before the formulation of the changes in design or improvements of the products by the Company.

The Company shall not be liable to compensate or indemnify the Purchaser, end user or any other party against any actions, claims, liabilities, injury, loss, loss of use, loss of business, damages, indirect or consequential damages, demands, penalties, fines, expenses (including legal expenses), costs, obligations and causes of action of any kind arising wholly or partly from negligence or omission of the user or the misuse, incorrect application, unsafe application, incorrect storage and handling, incorrect installation, lack of maintenance, improper maintenance or improper operation of products furnished by the Company.

Visit [www.thermon.com](http://www.thermon.com) to contact a Thermon representative near you.