

NOTES:

1. ALL DIMENSIONS IN INCHES, UNLESS OTHERWISE SPECIFIED.
2. BOLT ON LEGS AND ACCESS PANELS SHOWN.
3. HEATER TO BE MOUNTED ON SECURE FOUNDATION.
4. SCADA NETWORK CONNECTIVITY VIA. RS-485 & MODBUS ASCII OR RTU.
5. HEAT OUTPUT RANGE:  
204,000 BTU/HR TO 900,000 BTU/HR LPG, OR  
230,000 BTU/HR TO 900,000 BTU/HR NG
6. BURNER EFFICIENCY: MIN. 95%
7. MATERIAL:  
CABINET - 14 Ga. GALVANIZED STEEL  
BURNER - 18 Ga. STAINLESS STEEL
8. NET WEIGHT: 650 lbs (295 Kg)  
SHIPPING WEIGHT: 730 lbs. (331 Kg)

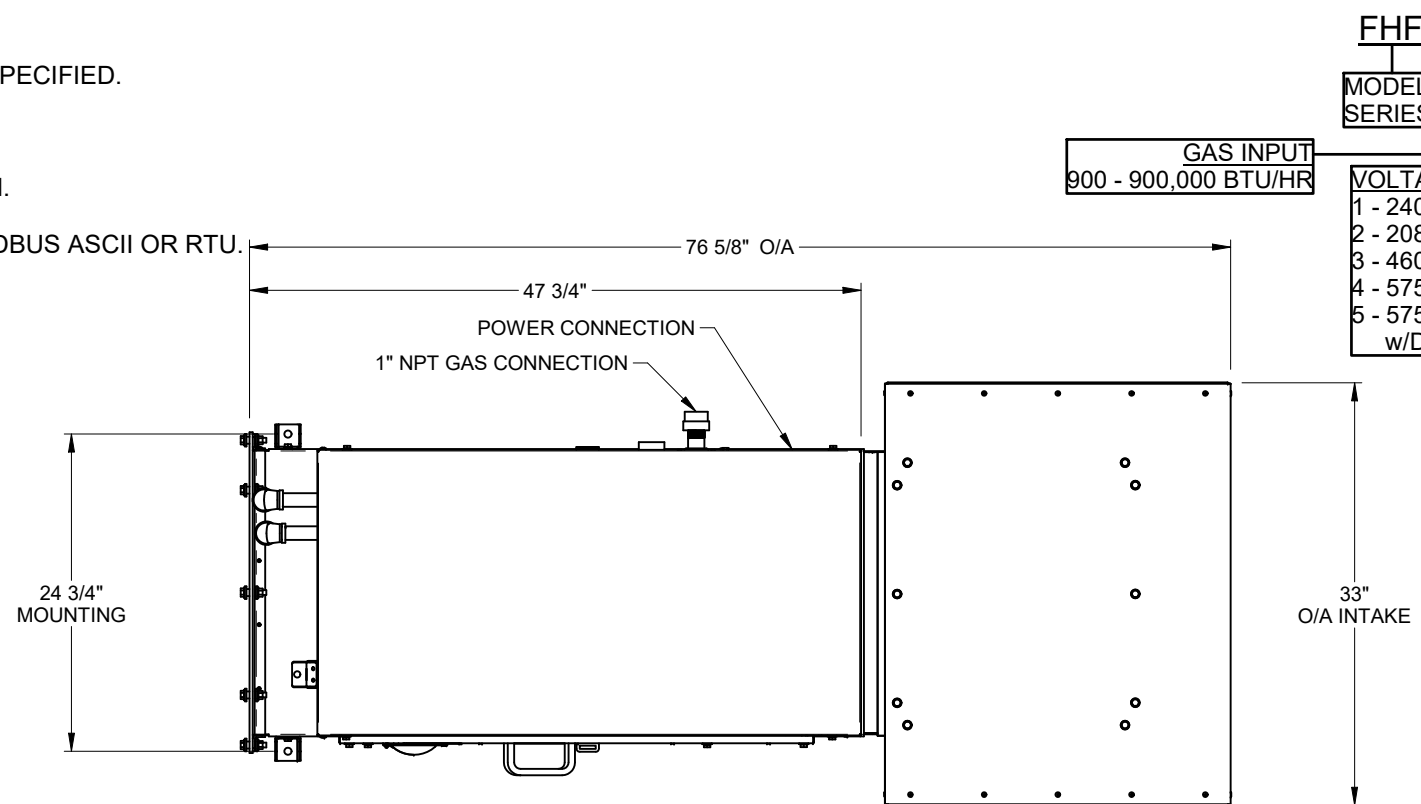

**FHF 905 - 1 1 - L B A - EMS - DG**

**MODEL SERIES**

**GAS INPUT**  
900 - 900,000 BTU/HR

**VOLTAGE**  
1 - 240  
2 - 208  
3 - 460  
4 - 575  
5 - 575  
w/DUPLEX

**PHASE**  
1 - 1 PH\*\*  
3 - 3 PH

**INTAKE**  
H - HIGH  
L - LOW

**LEVELLING LEGS**  
B - BOLT ON  
S - SCREW TYPE

**CONTROL ACCESS**  
A - BOLT ON  
Q - QUICK RELEASE

**ACCESSORIES**  
D - DIRT TRAP  
F - 48" GAS HOSE  
G - 72" GAS HOSE  
L - LOCKING BAR  
R - 2nd STAGE GAS REGULATOR  
M - MOTOR CURRENT KIT  
B - BUNGALOW  
S - SAFETY SHUTDOWN\*  
C - MOTOR CURRENT LIMITER\*\*  
P - POWERED RUN INDICATION

**ENERGY MANAGEMENT SYSTEM**  
EMS - SNOW AND RAIL T'STAT  
S - SNOW DETECTION  
T - RAIL T'STAT

\*\* ONLY AVAILABLE IN 240V  
\* ONLY AVAILABLE WITH BUNGALOW OPTION

GAS FIRING INFORMATION		
	PROPANE	NATURAL GAS
INPUT RATING, BTU/HR (kW)	204,000 - 900,000 (60-264)	230,000 - 900,000 (67-264)
MANIFOLD PRESSURE, INCHES OF WATER (kPa)	5-11.5 (1.25-2.86)	6-18 (1.49-4.48)
SUPPLY PRESSURE, PSI (kPa)	5-20 (34-138)	5-20 (34-138)

ELECTRICAL INFORMATION					
VOLTAGE	PHASE	WIRING	RUNNING AMPS	FREQUENCY (Hz)	MOTOR HP
240	1	3 WIRE, L1, L2, N	27	60	5
208	3	4 WIRE, L1, L2, L3, N	15.2	60	5
460	3	3 WIRE, L1, L2, L3	7	60	5
575	3	3 WIRE, L1, L2, L3	5.6	60	5

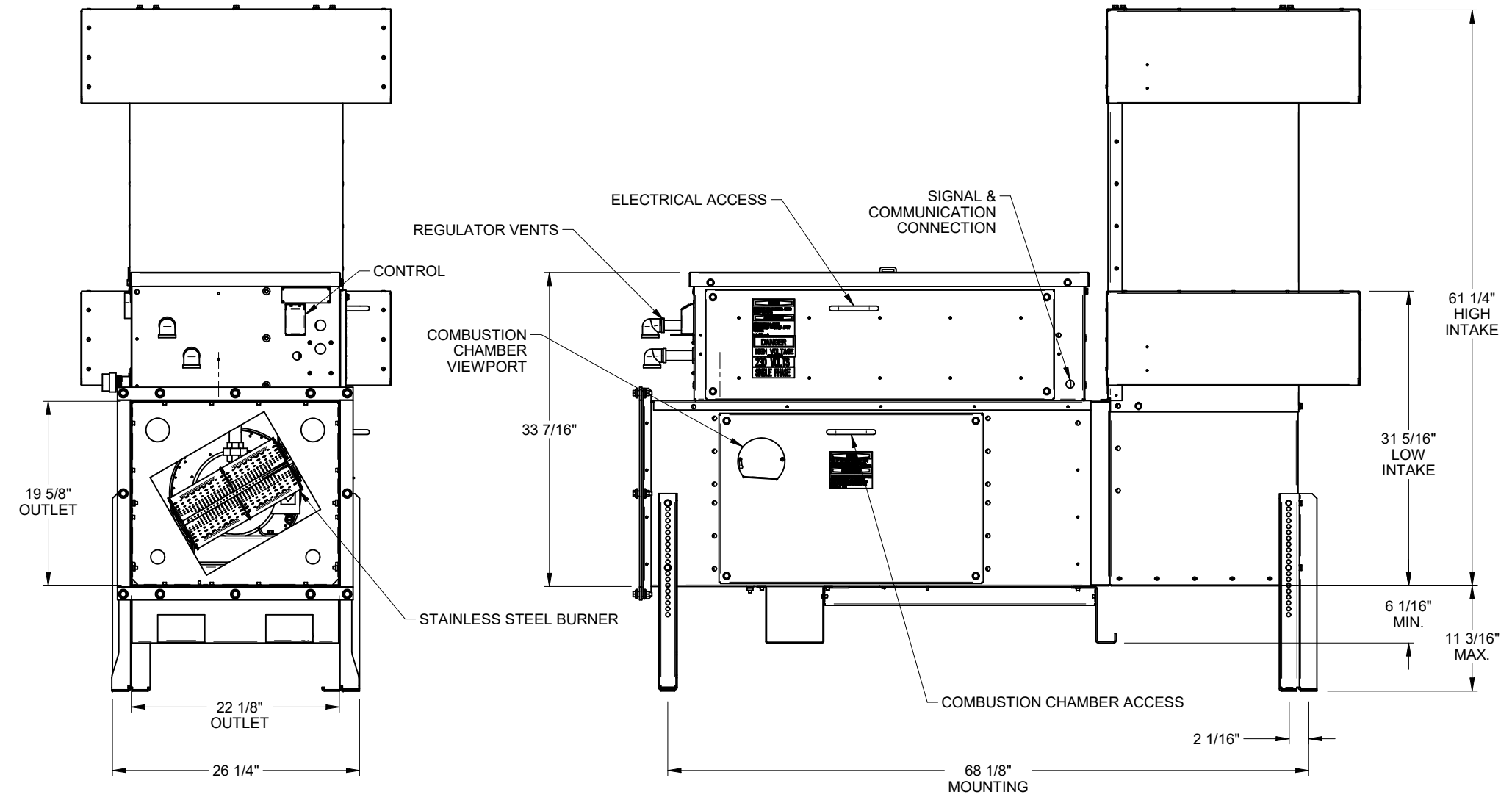

1	GAS FIRING INFO UPDATED	23AUG2021	GM
REV.	REVISION DESCRIPTION	DATE	BY
TITLE: <b>HF905 5HP GENERIC APPROVAL DWG</b>			
DWG NO.: 52597	SHEET: 1 of 2	TOLERANCE UNLESS NOTED OTHERWISE	
P/N: FHF905	SCALE: NTS	± 1/2" ANGULAR	± 0.005" DECIMAL
DRN BY: GMillard	26 JUL 2021	± 1/16" FRACTIONAL	± 1 mm METRIC
CHK'D BY: DJ			
APP'D. BY: N/A			

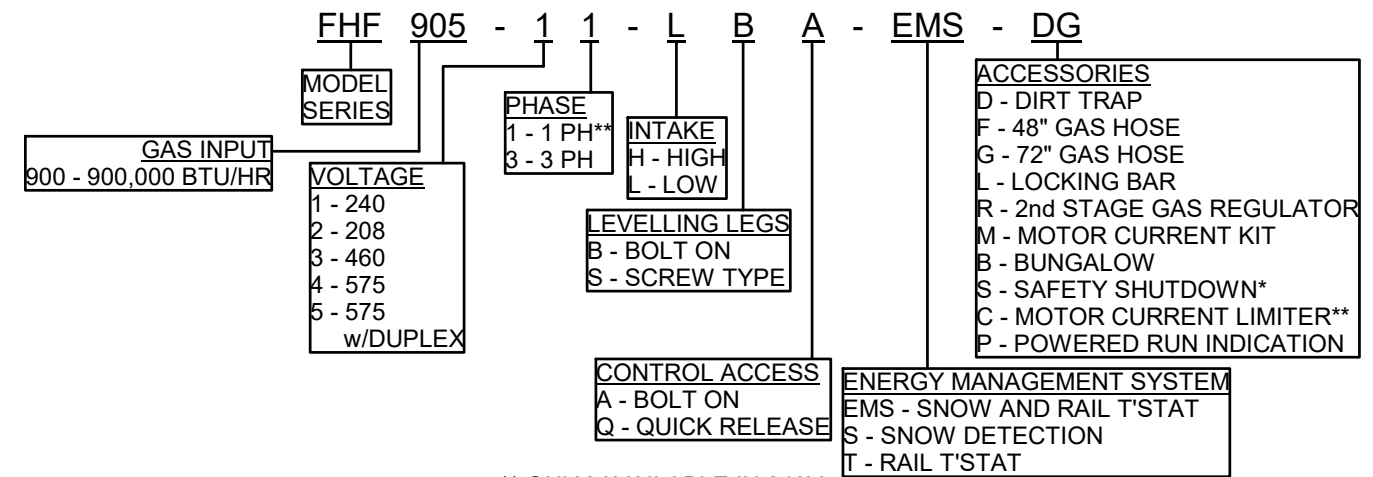

\*\* ONLY AVAILABLE IN 240V  
\* ONLY AVAILABLE WITH BUNGALOW OPTION

**ACCESSORIES OPTIONS:**

- F - HF15900-02 - 72" FLEX GAS HOSE
- G - HF15900-01 - 48" FLEX GAS HOSE
- D - HF16984 - DIRT TRAP AND STRAINER
- L - HF17436-01 - LOCKING BARS

**ENERGY MANAGEMENT OPTIONS:**

- EMS - HF19030 - EMS SYSTEM
- OR
- S - HF19031 - SNOW DETECTION ONLY
- OR
- T - HF19032 - RAIL THERMOSTAT ONLY

**LEVELLING LEGS OPTIONS:**

- B - HF19027 - BOLT ON MOUNTING LEGS
- S - HF16357 - SCREW TYPE MOUNTING LEGS

**CONTROL ACCESS OPTIONS:**

- Q - HF20053 - QUICK RELEASE ACCESS PANELS
- A - HF20056 - BOLT ON ACCESS PANELS

**INTAKE OPTIONS:**

- H - HF20043-02 - HIGH INTAKE
- L - HF20043-01 - LOW INTAKE

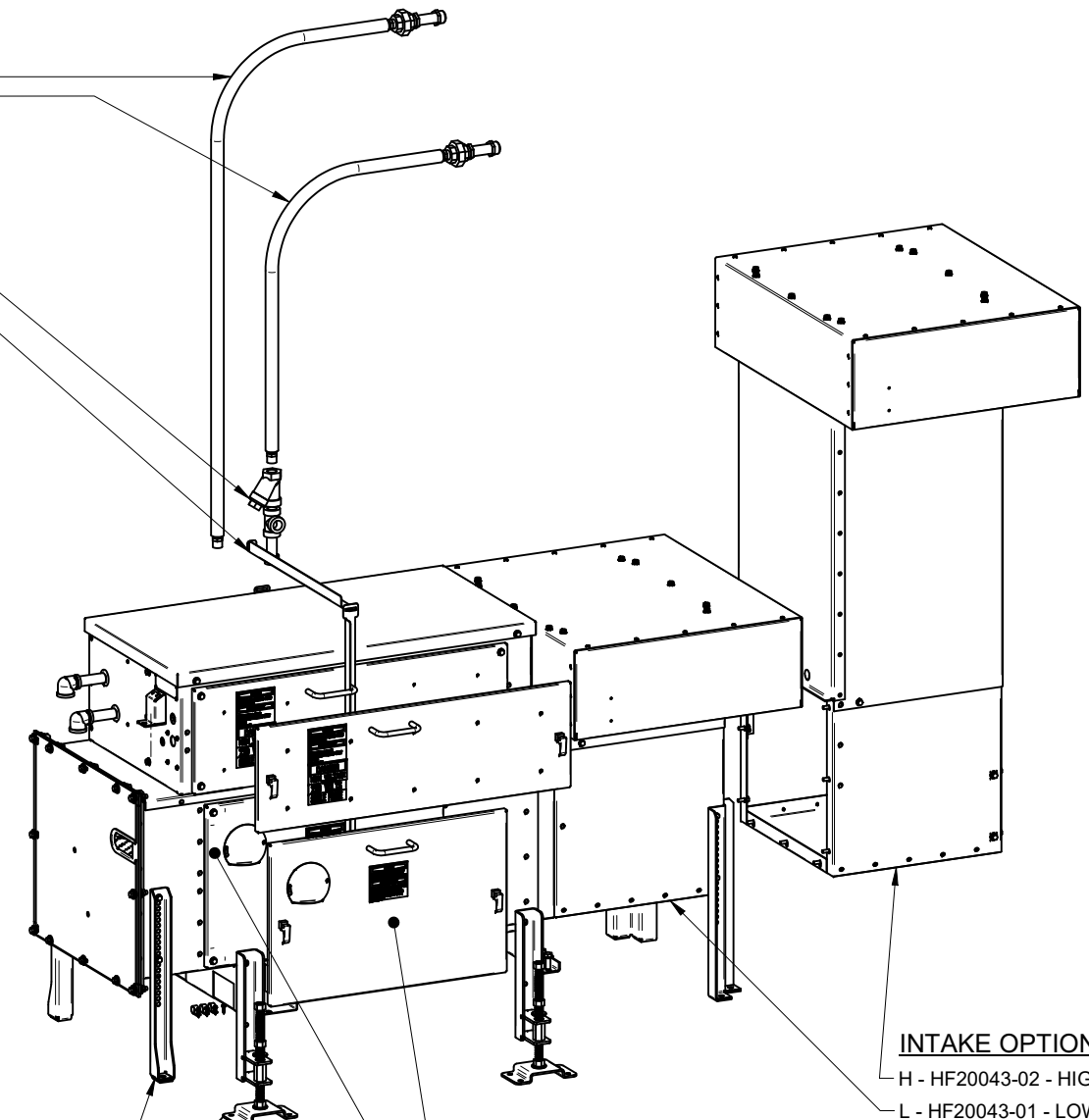

1	GAS FIRING INFO UPDATED	23AUG2021	GM
REV.	REVISION DESCRIPTION	DATE	BY
TITLE: <b>HF905 5HP GENERIC APPROVAL DWG</b>			
DWG NO.: 52597	SHEET: 2 of 2	TOLERANCE UNLESS NOTED OTHERWISE	
P/N: FHF905	SCALE: NTS	± 1/2" ANGULAR	± 0.005" DECIMAL
DRN BY: GMillard	26 JUL 2021	± 1/16" FRACTIONAL	± 1 mm METRIC
CHK'D BY: DJ			
APP'D. BY: N/A			