



## IMPORTANT INSTRUCTIONS - SAVE THESE INSTRUCTIONS

Read all instructions before installing or using the heater. Please adhere to instructions published in this manual. Failure to do so may be dangerous and may void certain provisions of your warranty.



## Gas Fired Railway Switch Heater

# 2020 HELLFIRE 905

## Installation, Operation, & Maintenance Instructions



# TABLE OF CONTENTS

<b>A. Important Notices And Warning Symbols</b>	<b>4</b>	E.15	Failure Shutdowns and Alarm Indications...	18	
<b>B. Identification</b>	<b>6</b>	E.16	Fault Conditions .....	18	
B.1	Heater Labels.....	6	E.17	Aggressive Retry Feature.....	19
B.2	Model and Serial Number Tag.....	6	E.18	Reset.....	19
B.3	Components Diagram.....	7	E.19	Energy Management System (EMS) .....	20
B.4	Control Panel Diagram - 240V Single Phase Example Shown.....	7	E.20	Terminal Blocks .....	21
B.5	Gas Manifold Diagram .....	8	E.21	Inputs and Outputs .....	21
<b>C. Pre-Operation Inspection</b>	<b>9</b>	E.22	Soft Starter Operation and Parameters .....	21	
C.1	Important Notices .....	9	E.23	Powered Run Indication Option.....	21
C.2	Prior to Heater Start-Up .....	9	<b>F. Troubleshooting</b>	<b>22</b>	
<b>D. Operation</b>	<b>11</b>	<b>G. Installation</b>	<b>26</b>		
D.1	Introduction.....	11	G.1	Overview.....	26
D.2	Modes.....	11	G.2	Recommended Tools.....	26
D.3	Start-Up Sequence (All Modes) .....	12	G.3	Site Preparation - Typical Clearances .....	26
D.4	Occurrences During Normal Operation.....	12	G.4	Site Preparation.....	29
D.5	Heat Output Adjustment.....	13	G.5	Heater Installation.....	29
<b>E. Controls &amp; Indications</b>	<b>14</b>	G.6	Gas Supply Piping and Minimum Pressure Drop .....	29	
E.1	AAR Signal Wiring - For non SCADA installations.....	14	G.7	Electrical Power Connections.....	29
E.2	Controller .....	14	G.8	Power Connections.....	30
E.3	Controls.....	15	G.9	Thermostat Installation.....	32
E.4	Indications.....	15	G.10	Energy Management System (EMS) Options .....	32
E.5	Terminal Blocks.....	16	G.11	Inspection and Commissioning.....	35
E.6	Data Communications.....	17	<b>H. Heater Specifications</b>	<b>36</b>	
E.7	Controller EEPROM Memory.....	17	H.1	Performance .....	36
E.8	Activating a COMMUNICATION Parameter .....	17	H.2	Gas Firing .....	36
E.9	Mode Parameters.....	17	H.3	Gas Conversion .....	36
E.10	Activating MODE Parameter .....	18	H.4	Electrical.....	36
E.11	Fan Mode.....	18	H.5	Controls.....	36
E.12	Local EMS Mode .....	18	H.6	Wiring Terminations.....	36
E.13	RAIL THERMOSTAT Mode, Normal .....	18	H.7	Safety Features.....	36
E.14	RAIL THERMOSTAT Mode, Reverse.....	18	H.8	Controller Terminal Identification.....	37
			H.9	Schematics .....	38

<b>I. Maintenance</b>	<b>46</b>
I.1 Thermostat Removal.....	46
I.2 Motor/Impeller/Base Removal.....	46
I.3 Impeller Removal .....	46
I.4 Flame Rod and Spark Igniter Removal.....	47
I.5 Burner Removal.....	47
I.6 Burner Defroster Removal .....	47
<b>J. Service</b>	<b>48</b>
J.1 Recommended Service Schedule .....	48
J.2 Gas Supply Pressure .....	49
J.3 Gas Supply Leak Test.....	49
J.4 Manifold Leak Test.....	49
J.5 Main And Safety Gas Solenoid Valves Leak Test .....	49
J.6 Dirt Trap And Strainer .....	49
J.7 Motor.....	49
J.8 Vibration Specifications and Measurement.....	50
J.9 Lubrication .....	50
J.10 Flame Safety Relay (FSR) .....	50
J.11 Flame Signal .....	50
J.12 Air Switch.....	51
J.13 Air Switch Calibration .....	51
J.14 High Temperature Limit.....	51
J.15 AAR Terminals, Signals, and Communications.....	51
J.16 Burner.....	52
J.17 Defroster .....	52
<b>K. Parts</b>	<b>53</b>
K.1 Parts - Heater Body.....	53
K.2 Parts - Control Panel, 240V Single Phase.....	54
K.3 Parts - Control Panel, 208V Three Phase .....	54
K.4 Parts - Control Panel, 460V/575V Three Phase.....	55
K.5 Parts - Control Panel, 460V/575V Three Phase with 120V Duplex Receptacle Control Panel Parts List.....	55
K.6 Gas Train .....	56

## A. IMPORTANT NOTICES AND WARNING SYMBOLS

Keep this manual with the machine at all times. The purpose of this manual is to provide owners, operators, and installers with the precautions and procedures essential for the safe and proper operation for its intended purpose.



**CAUTION.** This symbol indicates a potentially hazardous situation, which, if not avoided, may result in personal injury or damage to the equipment.







**WARNING.** This symbol indicates an imminently hazardous situation, which, if not avoided, can result in serious injury or damage to the equipment.









**DANGER.** Read and adhere to the following. FAILURE TO DO SO MAY RESULT IN SEVERE OR FATAL INJURY. Warranty will be void.

**NOTE:** "NOTE:" indicates information or a company policy that relates directly or indirectly to the safety of personnel or protection of property.

Table 1 – Operation Warning/Avertissements (Intended for Signal Maintainers)

Symbol	Description	
	English	French
	<p>Risk of electrical shock or electrocution.</p> <p>Disconnect electrical power prior to servicing.</p>	<p>Risque de choc électrique ou d'électrocution.</p> <p>Couper le courant avant d'entreprendre l'entretien.</p>
	<p>The heater is designed and approved for use as a commercial heater (gas) – railway switch, class 2902 05 in accordance with ANSI Z83.7 / CSA 2.14. Check with local authority, if you have questions about applications.</p>	<p>Cet appareil a été conçu et approuvé pour être utilisé comme radiateur commercial (gaz) - aiguillage de voie ferrée de classe 2902 05, conformément à la norme ANSI Z83.7 / CSA 2.14. Communiquez avec les autorités locales pour plus de renseignements sur le lieu d'utilisation de cet appareil.</p>
	<p>General hazard warning failure to comply with the precautions and instructions provided with this heater, can result in death, serious bodily injury and property loss or damage from hazards of fire, explosion, burn, asphyxiation, carbon monoxide poisoning, and / or electrical shock.</p> <p>Only persons who can understand and follow the instructions should use or service this heater. If you need assistance or heater information such as an instructions manual label, etc. Contact the manufacturer.</p>	<p>Mises en garde générales le non-respect des mises en garde et des instructions fournies avec ce radiateur peut entraîner la mort, des graves blessures et des pertes matérielles ou des dommages à la propriété résultant d'un incendie, d'une explosion, de brûlures, d'asphyxie, d'empoisonnement au monoxyde de carbone et/ou d'un choc électrique.</p> <p>Seules les personnes aptes à comprendre et à suivre les instructions devraient se servir de ce radiateur ou le réparer. Si vous avez besoin d'aide ou d'informations concernant ce radiateur, soit une notice d'instructions, une étiquette, etc., Prière de communiquer avec le fabricant.</p>
	<p>Fire, burn, inhalation, and explosion hazard. Keep solid combustibles, such as building materials, paper, or cardboard, a safe distance away from the heater as recommended by the instructions. Never use the heater in spaces which do or may contain volatile or airborne combustibles, or products such as gasoline, solvents, paint thinner, dust particles or unknown chemicals.</p>	<p>Risque d'incendie, de brûlures, d'inhalation et d'explosion. Garder les combustibles solides, tels les matériaux de construction, le papier et le carton, à bonne distance de ce radiateur, comme il est recommandé dans les instructions.</p> <p>Ne jamais utiliser cet appareil dans des endroits qui contiennent ou pourraient contenir des combustibles volatiles ou en suspension dans l'air tels l'essence, les solvants, les diluants pour peinture, les particules de poussières ou des produits chimiques inconnus.</p>
	<p>Not for home or recreational vehicle use.</p>	<p>Ne pas utiliser dans une maison ou un véhicule de camping.</p>
	<p>All persons employed in handling propane or natural gas shall be trained in proper handling and operating procedures, as required by local authorities having jurisdiction.</p>	<p>Toute personne qui manipule le propane ou le gaz naturel doit avoir suivi une formation sur les bonnes procédures de manipulation et d'utilisation qui est conforme aux exigences des autorités locales compétentes.</p>

Symbol	Description	
	English	French
	If you smell gas; immediately extinguish all sources of ignition and turn off gas source. Call qualified service technician to repair leak.	S'il y a une odeur de gaz : fermer immédiatement toute source d'allumage et de gaz. Faire réparer la fuite par un technicien qualifié.
	Do not attempt to manually light burner. Heater equipped with an automatic electronic ignition system.	Ne pas allumer le brûleur manuellement. Radiateur équipé d'un système d'allumage électronique.
	Risk of cutting fingers or hand. Disconnect fan power prior to removing combustion chamber access panel or air intake.	Risque d'amputation des doigts ou de la main. Couper le courant au ventilateur avant d'enlever le panneau d'accès à la chambre de combustion ou l'entrée d'air.
	Heater can start automatically. Exercise caution when in close proximity.	Attention : le radiateur peut démarrer automatiquement. Faire preuve de prudence près du radiateur.
	Burn hazard / hot surfaces. Do not touch track ducts, nozzles or any non-insulated duct connected downstream of heater during operation.	Surface chaude; risque de brûlure. Ne pas toucher les conduits latéraux à la voie ferrée, les buses ni aucun conduit non isolé branchés en aval d'un radiateur en marche.
	Sheet metal edges can be sharp. Wear protective clothing when handling track duct, insulated ducts and any other sheet metal components.	Risque de coupure. Les rebords de la tôle sont coupants. Porter des vêtements protecteurs lors de la manipulation des conduits isolés et tout autre composant en tôle.
	For use with ductwork only.	Pour utilisation avec réseau de gaines seulement.
	Retain manual for future reference.	Conserver le manuel pour consultation ultérieure.

## B. IDENTIFICATION

### B.1 Heater Labels

- Each heater has a ratings label, a logo label, a model and serial number tag and a voltage label.
- The ratings label contains all identification and safety information. It is fastened by a lanyard and stored in the manual pocket inside the control enclosure next to the gas manifold. The electrical specifications are indicated with a punch mark.

- The logo, located on the side of the air intake hood identifies the series as HELLFIRE, and the size, either 400, 900 or 905.
- The model / serial number tag is a blue aluminum plate. The model number is applied to an adhesive backed label bonded to the tag, and the serial number is engraved. The serial number is a sequential 6-digit number.

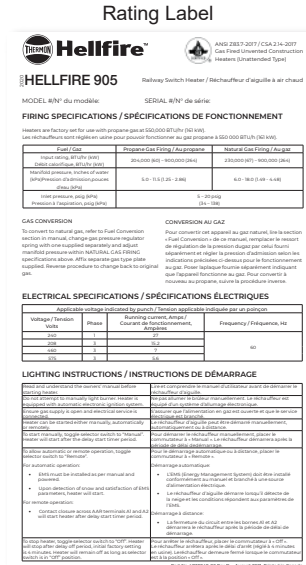
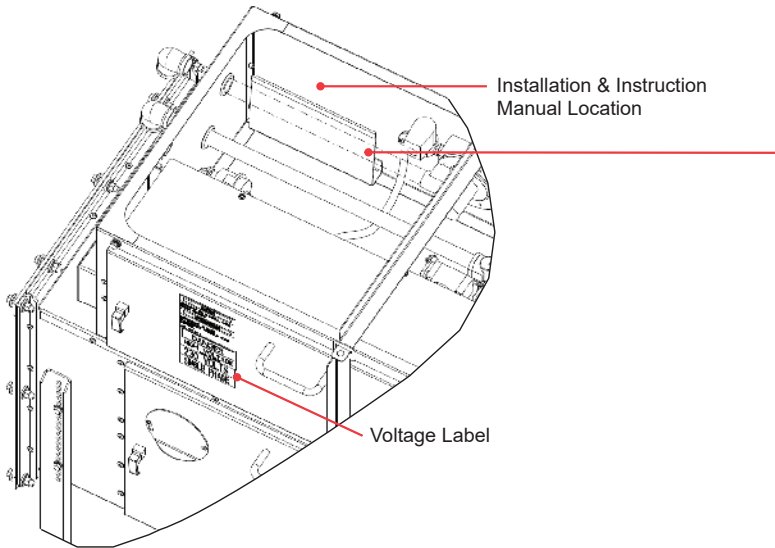

### B.2 Model and Serial Number Tag

- The tag is located on the front and above the selector switch.
- This is true for all configurations including heaters supplied with the bungalow option.
- Configurations are identified on the tag as model "HF 905" followed by a 5-digit number, an optional 2-digit dash number and a revision letter. For example, HF905 12345-01A (HF905 BUNG XXXXX-XXX - for bungalow enclosed heaters).

- The operating voltage label is found on the electrical access panel. Have this information available when requesting parts or service.

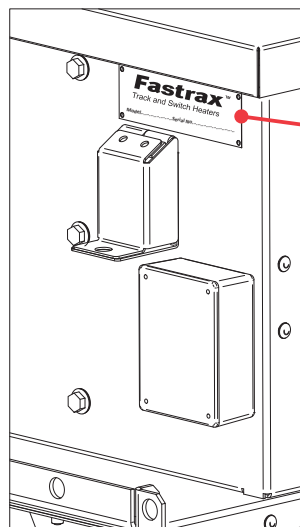

**Identification Tag with Model and Serial Number**  
Stand- Alone & Bungalow Enclosed Configurations



### B.3 Components Diagram

1. The following component names are referred to in this manual. See Section L - Parts for part numbers and ordering.

No.	Label
1	Track duct
2	Track duct elbow
3	Rail mounting spring clip and pad
4	Ballast retainer
5	Thermostat box
6	Precipitation detector
7	Burner
8	Regulator vents
9	Condensation vent
10	Gas manifold
11	Control cabinet lid
12	Air intake hood
13	Ambient air temperature sensor
14	Air intake extension
15	Identification tag
16	Mode selector switch

No.	Label
17	Electrical control access panel
18	Air intake plenum
19	Leveling leg
20	Control panel
21	Motor/Impeller/Base
22	Combustion chamber access panel
23	Transition duct
24	Sensor duct
25	Square to round adapter
26	Flex duct
27	Track duct deflector
28	Tie duct
29	Rail thermostat
30	Point nozzle
31	Track duct mounting bracket

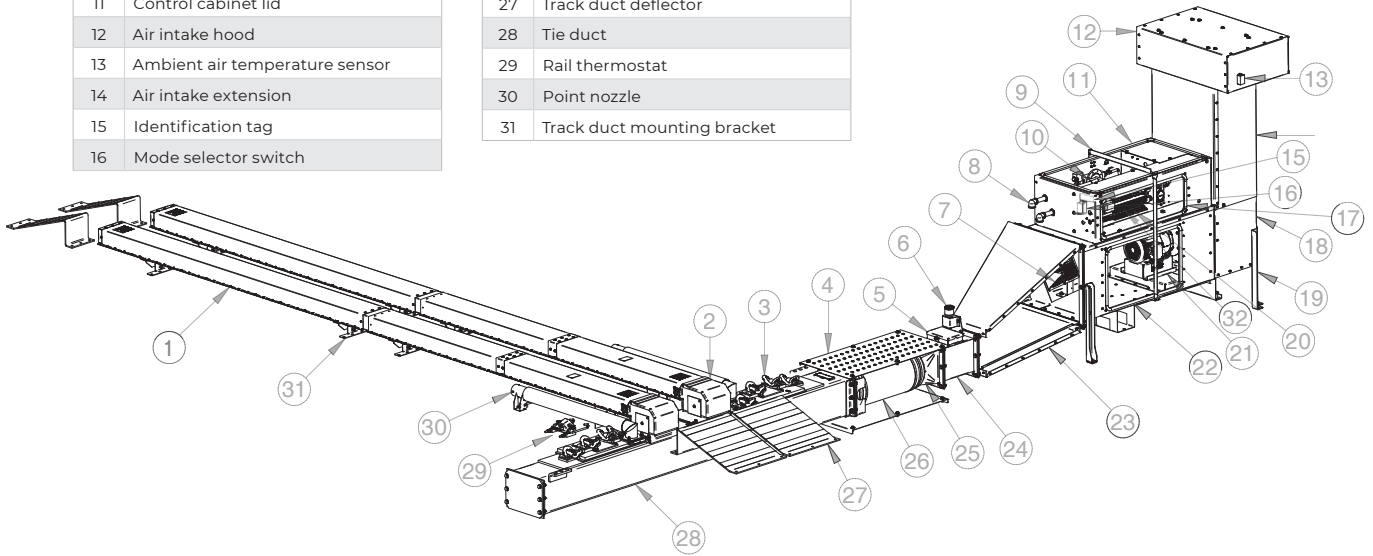

### B.4 Control Panel Diagram - 240V Single Phase Example Shown

No.	Label
1	Ignition transformer
2	Burner control / Flame Safety Relay
3	Purge timer card
4	Reset module
5	Controller
6	Programming key
7	EMS module
8	Control circuit breaker
9	Motor circuit breaker
10	120V receptacle
11	Contactors
12	Control transformer
13	Power terminal block
14	Mode selector switch
15	Hour meter
16	Receptacle circuit breaker
17	Tank valve circuit breaker
18	Control and indication terminal block

No.	Label
19	Resettable fuse, burner defroster
20	Manifold terminal block
21	Rail thermostat receptacle
22	Precipitation detector receptacle
23	Flame signal amplifier
24	Motor Soft Starter
25	Relay
26	24 VDC Power Supply

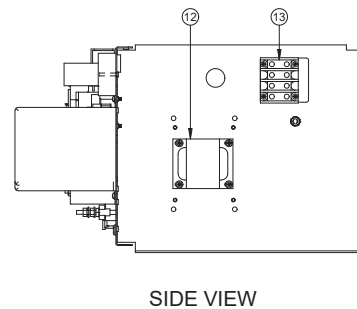
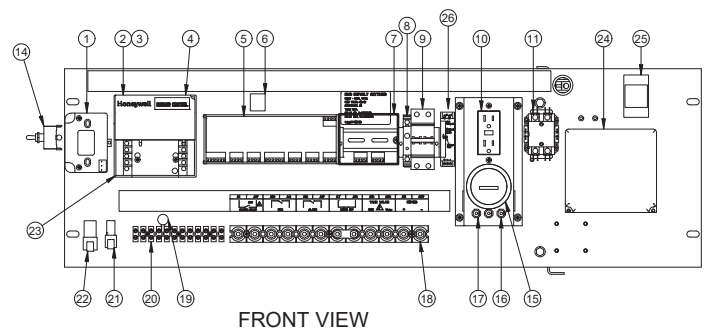

## B.5 Gas Manifold Diagram

No.	Label	No.	Label
1	Regulator vent	11	Main manual shutoff valve
2	Regulator vent pipe	12	Union
3	Pilot gas solenoid valve	13	Burner mounting bracket
4	Pilot gas pressure regulator	14	Burner defroster
5	Pilot manual shutoff valve	15	Igniter
6	Gas supply inlet	16	Flame rod
7	Gas supply pressure gage	17	Burner
8	Main gas pressure regulator		
9	Main and safety gas solenoid valves		
10	Manifold gas pressure gage		

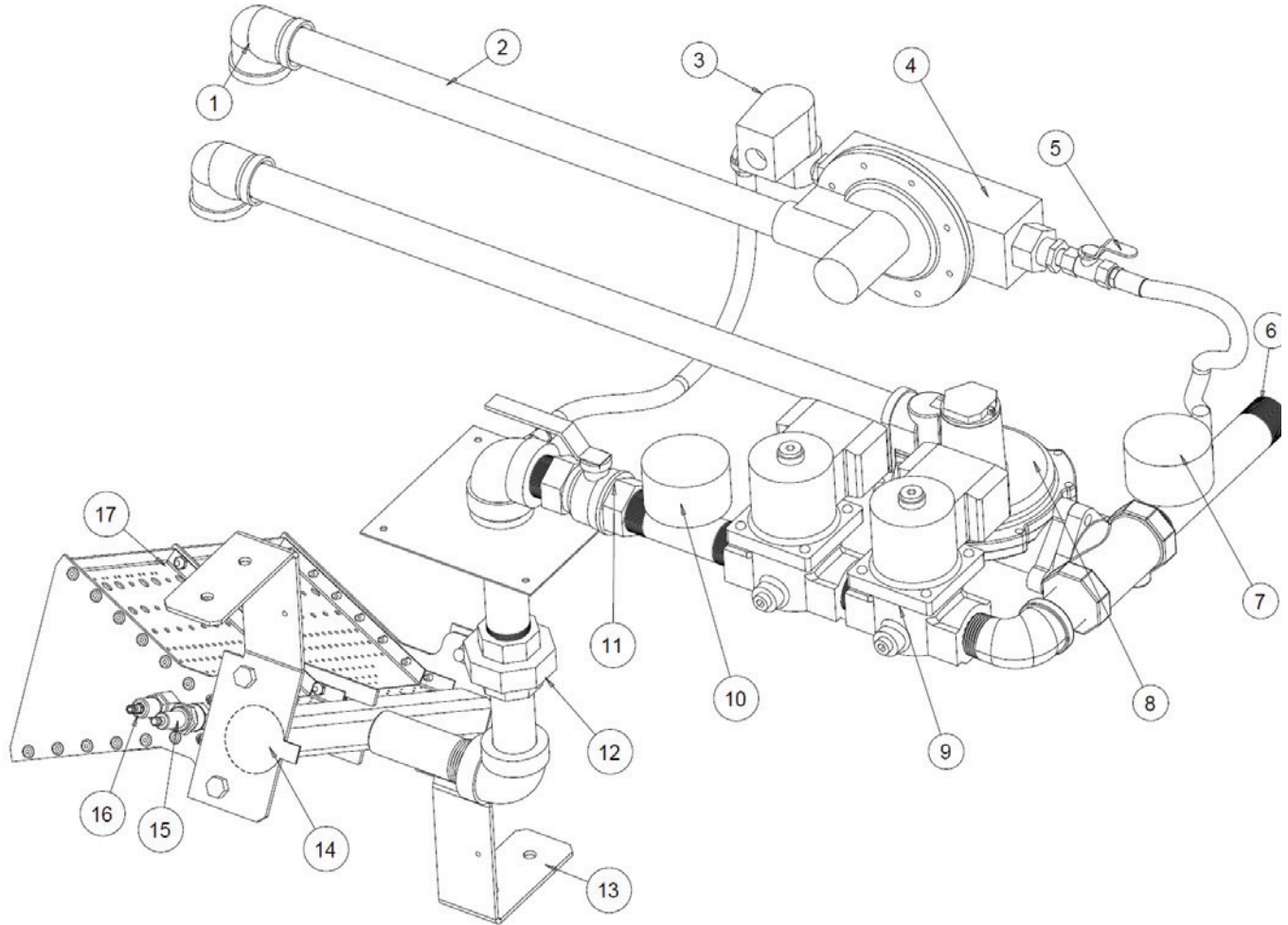



## C. PRE-OPERATION INSPECTION

### C.1 Important Notices



**WARNING.** All persons employed in handling propane or natural gas shall be trained in proper handling and operating procedures, as required by local authorities having jurisdiction.

Gas leaks shall be repaired immediately or, gas supply valve closed until repairs can be made.

All work performed on railway property must be carried out in accordance with local railway authorities instructions.

**NOTE:** Perform inspection and operations in accordance with the instructions provided in the service section of this manual.

**NOTE:** This inspection guide assumes that all applicable service bulletins have been implemented on the heater being inspected.

**NOTE:** The outcome of any inspection items that differ from that expected indicates further service is required.



**CAUTION.** Do not operate this machine until it has been installed and commissioned according to requirements specified in the installation section of this manual.

### C.2 Prior to Heater Start-Up

Table 2 – Heater Inspection List

Inspect	Action
Condition of all ducting, particularly any flex ducts	Repair or replace damaged ductwork.
Inside of all tie duct and cross ducts	Remove any blockages, such as debris and mud.
Track duct vents	Close vents that do not direct air at tie plates or rods. Set vent openings to 1/8" - 1/4" maximum.
Track duct mounting	Verify track ducts do not interfere with normal movement of the switch points and do not interfere with the signal system.
Flame rod and spark igniter	Remove and visually inspect for cracks in the ceramic, and evidence of soot. Replace any with cracked ceramic. If evidence of soot is found, clean rod and investigate condition of burner, gas manifold, and inspect tie duct, cross ducts and air intake for blockage.
Flame rod and ignition wires	Inspect boot for degradation, cracks and poor seals. Replace if necessary. Inspect connectors for signs of corrosion. Clean connections, or replace wire if necessary.
Combustion chamber	Verify it is clear of any obstructions or debris, ie. animal nests.
Cycling and high limit thermostat installation	Verify thermostats are fastened and are in full contact with duct surface. Replace any with damaged wire insulation. Verify thermostat enclosure is sealed and dry inside.
Service surge protection	Verify electric service has functioning surge protection.
Air switch port and vent	Remove any obstruction.
Gas regulator vents	Remove any obstruction.
Flame Safety Relay	Verify it is installed and is in standby mode with 'POWER' LED blinking, and 'ALARM' LED off.
Gas source	Verify propane tank is filled, or natural gas service is open and has pressure. Open all manual gas shut off valves and inspect all gas lines for leaks.
Electrical service	Verify electric service power is on. Close supply circuit breakers.

Inspect	Action		
Flame Safety Relay Burner Control fault histories	Using Honeywell display module S7800A1001 (Part number 9040-0021). Review and record the last 6 stored fault history error codes. See Honeywell manual for description of faults.		
	H1 Code	Hour	Cycle
	H2 Code	Hour	Cycle
	H3 Code	Hour	Cycle
	H4 Code	Hour	Cycle
	H5 Code	Hour	Cycle
	H6 Code	Hour	Cycle
Electrical supply	Verify correct line voltages at each heater. Must be within +/- 5% of nominal voltage. Verify current draw is less than or equal to nameplate rating.		
Gas supply	Verify supply and manifold gas pressures are within nameplate limits when heater and all connected loads are operating.		
Flame signal strength	Verify flame signal strength is stable (+/- 0.5) and between 3.0 and 5.0 Vdc. If signal strength is low: <ul style="list-style-type: none"> <li>- Clean or replace flame rod.</li> <li>- Clean flame rod wire connections, or replace wire.</li> </ul> If cleaning or replacement of flame rod and wire does not increase strength, have burner serviced or replaced.		
Burner operation	Note current manifold pressure. Set manifold pressure to maximum nameplate setting, measure point nozzle temperature, if point nozzle temperature is 140°F or less above ambient air temperature have burner serviced or replaced. Return manifold pressure back to desired setting.		
Air switch calibration	Block air intake 80%. Verify heater still operates. Then block 90% and verify FSR alarms. If heater fails with 80% or less blockage, recalibrate air switch.		
Control and indication wiring	Verify the correct control and indication wiring between the heater and the signal bungalow.		
Energy Management System (EMS)	If heater is operated automatically by an Energy Management System: <ul style="list-style-type: none"> <li>- Verify EMS module is installed and connected with POWER LED lit.</li> <li>- Verify controller is in AUTO mode.</li> <li>- Verify precipitation detector and ambient temperature sensor installed and connected.</li> <li>- Verify rail thermostat is mounted on rail and connected to surge isolator.</li> <li>- Verify its operation.</li> </ul>		
Aggressive retry	Verify operation. Turn gas supply off, toggle heater to "Manual". Verify three attempts made followed by lockout. Return heater to desired operating mode. Open gas supply. Reset controller. Verify display reads between 9 and 14A once motor is running at full speed.		
Motor Soft Starter (If Equipped)	Verify Motor Soft Starter is configured correctly as specified in Soft Starter Operation and Parameters Manual (Document No. THS3010-0621)		

## D. OPERATION

---

### D.1 Introduction

The switch heater is a gas fired, hot air heating system that keeps a turnout clear of ice and snow during winter storms by blowing hot air, between the stock rail and moving points, at the tie plates on which the points slide, and at the gage rods.

### D.2 Modes

The heater can be operated in the following modes:

1. **MANUAL** - by toggling the mode selector switch to "MANUAL", the heater will turn on and operate continuously. If installed, the rail thermostat will cycle the burner on and off as required to maintain the rail temperature.
2. **AUTO** – With the controller configured for LOCAL AUTO MODE, toggling the mode selector switch to "AUTO/REMOTE", and with an EMS module, precipitation and ambient temperature sensor installed, the heater will turn on or off as required based on the weather conditions. If installed, the rail thermostat will cycle the burner on and off as required to regulate the rail temperature.
3. **REMOTE RTC**- by toggling the mode selector switch to "AUTO/REMOTE" and with a Rail Traffic Control, RTC (dispatcher) operated control relay contact wired to terminals A1 and A2 of the control and indication terminal block. With RTC timer disabled, the heater will operate continuously while the RTC contact is closed, if the RTC timer is enabled, the heater will run for the duration of the RTC timer then stop. RTC can restart the heater for additional run time by resetting the request. If installed, the rail thermostat will cycle the burner on and off as required to maintain the rail temperature.
4. **REMOTE SCADA** - With the controller configured for REMOTE SCADA MODE, toggling the mode selector switch to "AUTO/REMOTE" with the heater connected to a Supervisory Control and Data Acquisition, SCADA, network via the controllers' RS-485 communications port, and configured with a Remote Control and Monitoring System (RCMS), software, the heater will operate automatically.  
  
If installed, the EMS module, precipitation detector, ambient temperature sensor and rail thermostat provides inputs to the RCMS software.
5. **OFF** – to disable the heater, toggle selector switch to "OFF".

### D.3 Start-Up Sequence (All Modes)

Once a start request is received the control sequence begins.

**NOTE:** If the controller is in 'REMOTE RTC' mode then it waits for the 'DELAY START' time before initiating.

Table 3 – All Modes

Conditions/Sequence	Status LED
Heater is in an operational mode not OFF.	ENABLE
Cycling thermostat is cold or closed.	CYCLING
Motor contactor closed, fan starts.	MOTOR
Air pressure develops, air switch closes.	AIR SW
FSR requested, trial for ignition, burner lit.	HEAT
Main gas valve opens.	FSR CHECK
Run indication contact closed.	RUN
To confirm the heater operation, the burner remains lit and the rail thermostat status is ignored for the first 2 minutes.	
Normal operation Heater runs as long as requested.	

### D.4 Occurrences During Normal Operation

**NOTE:** The rail thermostat closes when the rail temperature is above 9°C (49°F) and opens when below 3°C (37°F).

6. As long as the rail is cold and the thermostat is open, the burner remains lit. Once the rail warms and the thermostat closes, the burner is extinguished. This cycle repeats as required while the heater operates. If the rail temperature remains warm for more than the post purge time then the fan is turned off. The run indication is maintained during this time.

7. If the heater is in 'REMOTE SCADA' mode and the 'Fastrax® RCMS' software is requesting performance operation, the burner will remain lit regardless of rail thermostat status.

**NOTE:** The cycling thermostat limits the heated air temperature to a maximum of 193°C (380°F). Under normal circumstances the air temperature remains below this limit.

8. If the heated air temperature becomes excessively hot, the cycling thermostat limit opens, and the burner is extinguished immediately. Once the air cools and the thermostat closes the burner is lit and heating resumes. Run indication is maintained during this time.

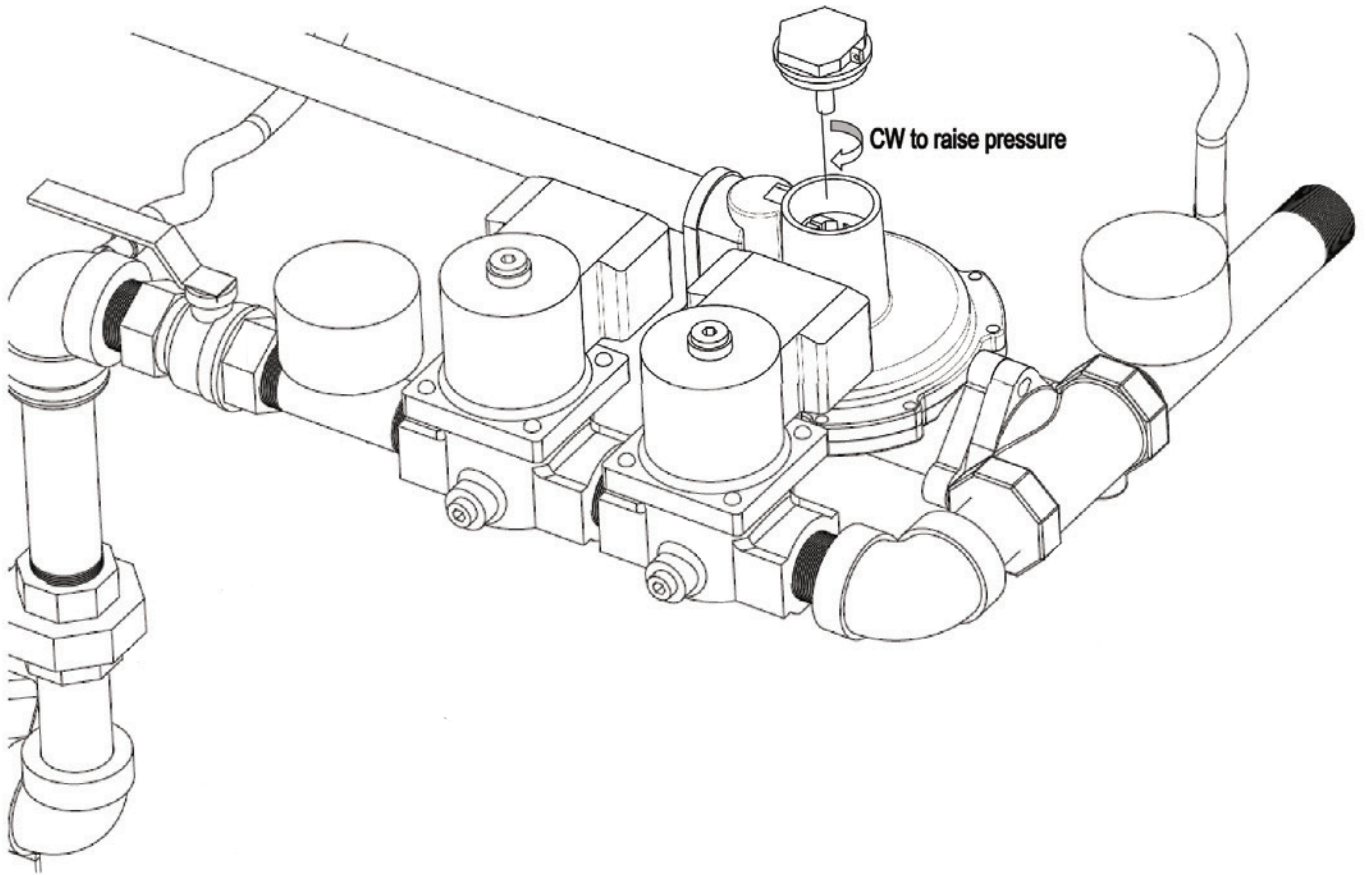

## D.5 Heat Output Adjustment

1. Depending on the length of switch points, its' priority, local climate conditions, and experience, the operator can increase or decrease the heat output accordingly. The recommended heat output is in the range of 10,000 to 22,000 BTU/hr per foot of turnout length.
2. The factory default setting is 550,000 BTU/hr when operated on LPG, or 390,000 BTU/hr on NG.
3. The heat output can be adjusted as follows:
  - 3.1 With the heater running, unscrew and remove the main regulator (8) cap.
  - 3.2 Use a flat blade screwdriver to turn the internal nut clockwise to raise (shown) or counterclockwise to lower pressure as indicated on the manifold pressure gage (10).
  - 3.3 Screw cap closed.
  - 3.4 As a starting point, with the heater operating, adjust the manifold gas pressure to attain an air temperature of 121°C (250°F) above ambient as measured at the near point nozzle.



**WARNING.** Do not operate above maximum manifold pressure as this can produce carbon monoxide in excess of maximum allowable of 0.08 AFCO.



**WARNING.** Do not operate above or below the rated manifold pressure limits. Operating outside limits will result in weak flame signal and unreliable operation.



**WARNING.** Install cap once regulator adjustment is complete. In the event of pressure relief, the cap must be closed to vent gas to the exterior.

## E. CONTROLS & INDICATIONS

### E.1 AAR Signal Wiring - For non SCADA installations

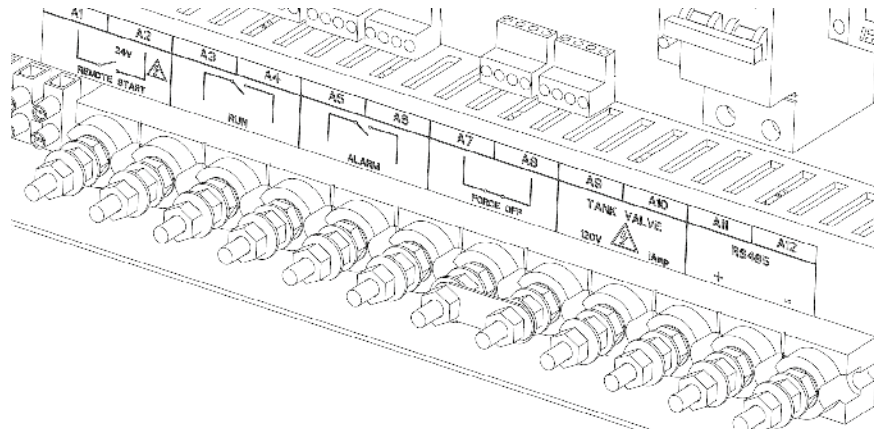

Table 4 – AAR Signal Wiring

Terminals	Label	Description
A1 - A2	REMOTE START	A contact closure across these terminals starts the heater when the heater is in REMOTE RTC mode.
A3 - A4	RUN	Standard - Dry contact closes to provide alarm indication. Optional Powered Run Indication (P) - 24 VDC is supplied to provide run indication.
A5 - A6	ALARM	Dry contact closes to provide alarm indication.
A7 - A8	FORCE OFF	Default is closed. If FORCE OFF function is desired, remove shorting link and replace with customer supplied relay contact. Open contact disables heater.
A9 - A10	TANK VALVE	These terminals are intended to operate a 120V AC gas supply solenoid shut off valve. They energize when the motor contact closes.
A11	RS-485 (+)	Communications, RS-485 positive terminal (for RCMS operation only)
A12	RS-485 (-)	Communications, RS-485 negative terminal (for RCMS operation only)

### E.2 Controller

1. The controller manages the operation of the heater and allows it to either operate on its own or be part of a network of heaters.
2. The controller monitors various inputs, controls the heater functions, communicates status and provides indication LEDs.
3. The controller is DIN rail mounted and all wiring connections are made with plug connectors to allow quick replacement in the event of a failure.
4. With the addition of the EMS package, a stand alone heater can operate automatically based on weather conditions, or when connected to a network, act as a weather station providing input to a SCADA system.
5. Its' RS-485 serial communications port allows the heater to interface with SCADA systems, and be operated and managed by a Remote Control and Monitoring System.

NOTE: Controllers are not interchangeable between HELLFIRE 400 (24V AC) and HELLFIRE 900 (120V AC).

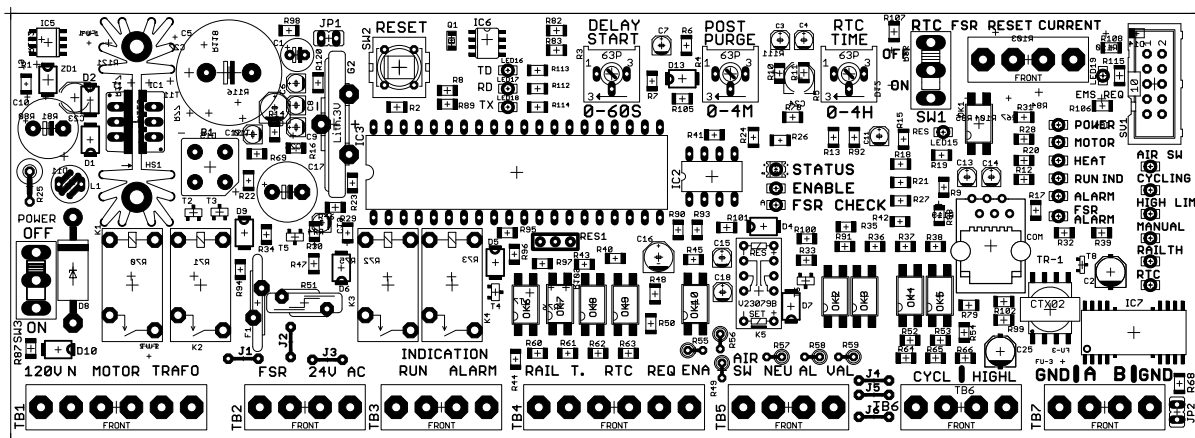

### E.3 Controls

1. **Power:** This switch turns the power supply to the board 'ON' or 'OFF'.



**WARNING.** 120V AC inputs to controller can remain energized.

2. **Reset:** This push button is used to reset the controller in case of a lockout.
3. **Delay Start:** This dial sets the length of the delay, 0 to 60 seconds, before starting the heater. It is intended to allow the stagger start of multiple heaters connected to one power service thereby reducing the maximum current draw. This setting is true for REMOTE RTC mode only. Under MANUAL, AUTO and REMOTE SCADA modes there is no delay.

**NOTE:** This setting is overridden when operated in REMOTE SCADA mode by the corresponding Fastrax® RCMS software parameter.

4. **Post Purge:** This dial sets the length of the delay, 5 seconds to 4 minutes, once the heater is no longer requested, before stopping the fan. It is intended to purge the remaining heat and moisture from the combustion and duct system. This setting is true for all modes.
5. **RTC Time:** (RTC stands for Rail Traffic Control dispatch) This dial limits the run time between 20 minutes to 4 hours, when requested by RTC dispatcher, and with the RTC SW switch ON, and the heater is in REMOTE RTC mode. When the RTC request exceeds the time limit, the heater turns off, and the run indication is maintained as long as the heater is requested.

Timer is reset once the RTC request is removed. RTC can then request the heater for another cycle.

It is intended to save fuel by avoiding unnecessary heater operation by the dispatcher. This setting is true for RTC MODE only. Under MANUAL, AUTO, and REMOTE SCADA modes there is no limit.

6. **RTC SW:** This switch enables the RTC TIME function when in the ON position. When switched OFF, RTC TIME is disabled and the heater runs as long as requested.
7. **JUMPER, JPI:** Used to configure controller parameters.

### E.4 Indications

1. On the controller are a number of status LEDs intended to aid the user's understanding of the heater state of operation. See Table 6 - Controller LED Descriptions for full description.

**NOTE:** With the exception of the communications TD, RD, and TX LED's. Solid green, solid green with a red pulse, or yellow LED's indicates normal status. Solid red and alternating LED's indicate a failure. This is true for the controller only, not the EMS module.

2. Refer to Section F - Troubleshooting for explanation of problem condition LED codes.
3. The LEDs listed can be found on the controller from top left to bottom right on the board.

Table 5 – Controller LED Descriptions

LED Name	Description	State	Indication
TD, RD, TX	RS-485 communications	TD, RD on and pulsing TX off and pulsing	Heater in REMOTE SCADA mode.
		TX off TD and RD on	Heater in LOCAL AUTO mode.
		TD, TX off and pulsing RD on	8N1 COM communications mode.
Status	Processor status	Solid green with a red pulse	Normal operation.
		Alternating red and green	FSR failure alarm. Aggressive retry mode in process.
		Solid red	Failure alarm. Note any alternating LEDs and refer to Section F - Troubleshooting. Controller must be reset.
		Solid green or off	Processor has stopped functioning.
ENABLE	Heater enable	On	Mode selector switch is either in MANUAL or REMOTE/AUTO position. Heater can be started in AUTO REMOTE RTC or REMOTE SCADA modes.
		Off	Mode selector switch is in OFF position. Heater is in OFF mode and will not start.
FSR CHECK	Flame Safety Relay check	On	Gas valve energised. Used to confirm correct operation of FSR.
		Alternating	The FSR did not energized the main gas solenoid valves when expected.
RES	FSR Reset	On	Controller clears FSR alarm.

LED Name	Description	State	Indication
EMS REQ	EMS request	On	EMS module request for heater to run. Heater only acts on this request if in AUTO mode.
POWER	Power supply	On	Controller energized.
MOTOR	Motor	On	Contact closed, motor turned on.
HEAT	Controller request for heat	On	FSR requested. Ignition sequence started or burner operating.
RUN IND	Heater run indication	On	Indication contact closed. Turns on after 60 seconds of normal operation.
ALARM	Heater alarm indication	On	Alarm indication contact closed. Heater off and locked out. Controller must be reset manually.
FSR ALARM	Flame safety relay alarm	On	FSR in ALARM, or controller is preventing its operation.
		Alternating	FSR is in ALARM. Heater failed 4 times in 5 minutes.
AIR SW	Air pressure switch	On	Contact closed. Sufficient air flow to allow burner operation.
		Alternating	Air switch did not operate as intended. Air switch either did not close with fan ON or did not open with fan OFF.
		Off with pulse on	Continuous fan mode with selector switch in OFF position.
		On with pulse off	Continuous fan mode with selector switch in MANUAL or REMOTE/AUTO position.
CYCLING	Cycling thermostat	On	Thermostat closed. Heated air temperature is BELOW set point.
		Alternating	Cycling thermostat open for more than 10 minutes.
HIGH LIM	High limit thermostat	On	Thermostat closed. Heated air temperature ABOVE set point.
		Alternating	High limit thermostat closed momentarily indicating air temperature exceeded set point.
MANUAL	Manual operation	On	Selector switch in "MANUAL" position. Heater in MANUAL mode.
RAIL TH	Rail thermostat	On	Thermostat open. Rail temperature is BELOW set point.
RTC	Rail traffic control mode	On	Indicates selector switch is in "REMOTE/AUTO" position and AAR terminals 1 and 2 are closed.
		Off with pulse on	Indicates selector switch is in "REMOTE/AUTO" position and requested by RCMS.
		On with pulse off	Indicates selector switch is in "REMOTE/AUTO" position and requested by RCMS and AAR terminals 1 and 2 are closed.

## E.5 Terminal Blocks

- The controller interconnects with the control panel by means of 8 board level headers, TB1 to TB8, which accept the various wire harness plug connectors. The controller and EMS module connect via a ribbon cable that plugs into the 10-pin header found on each.

Table 6 – Terminal Block Description

Name	Description
JP1	Jumper. Used to configure EEPROM settings
TB1	120V power, transformer primary and motor contactor coil output
TB2	Transformer secondary 24V power and FSR request output
TB3	RTC run and alarm indication contacts outputs
TB4	Rail thermostat, RTC request, Manual, and Enable inputs
TB5	Air switch, FSR/DSI alarm, gas valve inputs
TB6	Cycling and high limit thermostats inputs
TB7	Communication port, RS-485
TB8	FSR reset and current transformer inputs
10-pin header*	EMS module power and signal connection

\*Located in the upper right corner next to TB8.



## E.6 Data Communications

1. The RS-485 serial communications port, and an EEPROM, allows the heater to be part of a Supervisory Control and Data Acquisition (SCADA) network and Remote Control and Monitoring System (RCMS) software.
2. The RS-485 port runs at 9600 baud and allows communication over long distances of up to 1000' and possibly longer.

**NOTE:** Cable construction: Cat5 24 AWG twisted pair is a very common cable type used for RS-485 systems. Adding shielding to the cable enhances noise immunity, and thereby allows greater distance. If used, connect one end only of shield to ground.

3. The 8-bit memory address allows a maximum of 254 heaters to connect to the same communications bus.

## E.7 Controller EEPROM Memory

1. EEPROM memory chip stores parameters and an address.
2. EEPROMs can be switched between controllers. In the event a controller needs to be replaced the EEPROM can be removed from the old and put in the replacement. The parameters and address remain with the heater and no RCMS software modifications are required.



**WARNING.** Electrostatic discharge can damage ICs. Have qualified personnel remove and install EEPROM IC.

3. Parameters activated locally or remotely by the RCMS software are stored on the EEPROM.

**NOTE:** There are two parameter types, 'COMMUNICATION' and 'MODE'.

**Table 7 – Communication Parameters (Activated Locally)**

Name	Setting <sup>1</sup>	Function
LOCAL AUTO MODE	1	Disables communications and enables local EMS control.
REMOTE SCADA MODE	2	Enables RS-485 MODBUS communication. Disables local EMS control. Enables weather station mode.
DEFAULT ADDRESS	3	Writes 254 to processor address. <sup>2</sup>
ADDRESS SET	4	Writes new address to EEPROM <sup>2</sup>
8N1 COM	5	Enables 8N1 communication. <sup>3</sup> Enables local EMS control.
LOCAL EMS, enabled	6	Enables local EMS control.
LOCAL EMS, disabled	7	Disables local EMS control.
FAN MODE	----	When enabled, the fan runs continuously. <sup>4</sup> When disabled, the fan runs only when heating is requested.

<sup>1</sup> Setting number equals alarm LED/relay count.

<sup>2</sup> One time functions.

<sup>3</sup> The 8N1 configuration allows the heater to send status information only and is intended to aid service technicians. This configuration does not allow the heater to be part of a network.

<sup>4</sup> See CONTINUOUS FAN MODE section for instructions.

## E.8 Activating a COMMUNICATION Parameter

**NOTE:** Read and understand the following procedure before starting. COMMUNICATION parameters require a hardware programming key to make changes, MODE parameters do not.

1. Toggle mode selector switch to "OFF". If installed, disconnect EMS cable from controller. Plug programming key into the mating EMS 10-pin connector. Then the red LED on the key lights.
2. Press the RESET button, and short jumper JP1.
3. Release the RESET button. The RTC, MANUAL, CYCLING, and AIR SWITCH LEDs will each pulse, one after the other for one sequence. Then the RUN indication LED pulses and the green LED on the programming key alternates on and off.
4. After five RUN indication pulses, the red ALARM LED lights for 3 seconds. This cycle continues as long as the jumper, JP1, is shorted.
5. Count the number of times the red ALARM LED lights.
6. Once the count equals the parameter number, remove the jumper before the ALARM LED turns off. For example, when the ALARM LED lights for the second time removing the jumper will activate REMOTE SCADA MODE, parameter #2.
7. Function performed.
8. Parameter or new address is stored on the EEPROM.
9. Repeat sequence as required to activate other parameters.

## E.9 Mode Parameters

**Table 8 – Mode Parameters**

Name	Parameter <sup>1</sup>	Function
FAN MODE ENABLE	1	Turns the motor on and keeps it running continuously.
FAN MODE DISABLE	2	Motor runs only when heater is requested.
LOCAL EMS MODE ENABLE	3	Local EMS controls the heater.
LOCAL EMS MODE DISABLE	4	The local EMS will not turn the heater on.
RAIL THERMOSTAT MODE NORMAL	5	Configures operation to new thermostat, open when cold, closes on temperature rise (COR).
RAIL THERMOSTAT MODE REVERSED	6	Configures operation to older rail thermostats that are closed when cold, open on temperature rise (OOR).

<sup>1</sup> Parameter number equals alarm LED/relay count.

### E.10 Activating MODE Parameter

**NOTE:** Read and understand the following procedure before starting.

1. The controller must be powered on for a minimum of 60 seconds, the mode selector switch toggled OFF, and terminals A1 A2 open (i.e. no RTC request).
2. Short jumper JP1. The RUN indication relay and LED pulses on and off. After five RUN indication pulses, the red ALARM LED lights for 3 seconds. This cycle continues as long as the jumper, JP1, is shorted.
3. Count the number of times the red ALARM LED lights.
4. Once the count equals the parameter number, remove the jumper before the ALARM LED turns off. For example, when the ALARM LED lights for the second time removing the jumper will activate FAN MODE DISABLE, parameter #2.
5. Function performed.
6. Parameter or new address is stored on the EEPROM.
7. Repeat sequence as required to activate other parameters.

### E.11 Fan Mode

1. When enabled for continuous operation, this mode can be beneficial for locations with difficult to detect drifting snow conditions that cause snow accumulation in the turnout and or in the duct system.
2. When enabled, and with the mode selector switch in either the MANUAL or REMOTE/AUTO position, the fan will run continuously, with heating requested or not.

**NOTE:** The fan will stop when the mode selector switch is in the OFF position.

3. This parameter can be set, either, locally, or remotely by the RCMS software.
4. Refer to RCMS documentation for remote activation.

### E.12 Local EMS Mode

1. This parameter enables the locally installed EMS module to control the heater according to the module set points. If connected to a SCADA system, all weather data will be transmitted to the system. No other functions are affected by this mode.
2. The HEAT LED pulses to indicate that the local EMS module can turn on the heater.
3. When disabled, the HEAT LED will not pulse. It will light up when conditions are met, but it will not turn on the heater.

### E.13 RAIL THERMOSTAT Mode, Normal

1. With the introduction of the 2014 model Hellfire, the rail thermostat operation was reversed. The thermostat now opens when cold and closes when warm.
2. When enabled, the controller is configured to operate with the new, close on rise (COR), thermostat.

### E.14 RAIL THERMOSTAT Mode, Reverse

1. When enabled, the controller is configured to operate with the previous, open on rise (OOR), thermostat.

### E.15 Failure Shutdowns and Alarm Indications

1. In the event of a failure, the controller ceases the heater operation and indicates alarm.
2. While the heater is shutdown and indicating alarm the controller continues communications with the RCMS software. All start requests, local or through the RCMS software, are ignored until the problem is resolved.
3. The controller indicates the nature of the failure in three ways. LED's on the controller, an alarm contact closure, and error codes communicated via the RS-485 serial port when under RCMS control.

**NOTE:** With the exception of the communications TD, RD, and TX LED's. Solid green, solid green with a red pulse, or yellow LED's indicates normal status. Solid red and alternating LED's indicate a failure. This is true for the controller only, not the EMS module.

4. There are two types of failure alarms, minor and major. Both cease the heater operation, however, minor alarms clear when the condition that caused the failure rectifies itself. Major alarms, which are more serious and require inspection, must be manually reset.

### E.16 Fault Conditions

1. A failure exists when the STATUS and the ALARM LED's are solid red.
2. In addition, an alternating LED of equal duration on and off, or red and green indicates the failure condition.
3. Heaters connected via the RS-485 port to a network and RCMS software will communicate fault codes.

Table 10 – Fault Condition Codes and LED States

Code	Alarm Type	Fault Condition	LED	State
1	Minor	Selector switch left in OFF position for more than 60 minutes.	ENABLE	Dark
2	Major	Air switch does not open after fan motor turned off.	AIR SW	Alternating
3	Major	Air switch does not close after fan motor turned on.	AIR SW	Alternating
10	Major	Flame failure at start up.	FSR ALARM	Alternating
11	Major	Loss of flame signal while running.	FSR ALARM	Alternating
12	Major	4 FSR alarms within 2 minutes.	FSR ALARM	Alternating
13	Major	Gas valve does not energize when expected.	FSR CHECK	Alternating
14	NA	FSR in alarm.	FSR ALARM	Solid Red
20	Minor	Cycling thermostat failed to close after 10 minutes.	CYCLING	Alternating
21	Major	Maximum output air temperature exceed. High limit thermostat closed momentarily.	HIGH LIM	Alternating
30	Minor	Controller in configuration mode. JPI jumper shorted.	(none)	
31	Minor	EMS module TEST switch on.	SENSOR WET	Solid Red

### E.17 Aggressive Retry Feature

1. The controller has an aggressive retry feature. It is intended to avoid nuisance failure shutdowns and alarm indications due to temporary conditions, such as condensation on the igniter and or flame rod, which are rectified with repeated attempts.
2. In the event of an FSR alarm, as indicated by the FSR ALARM LED, occurring at start up or under normal operation, this feature will reset the FSR and allow up to 4 trials for ignition attempts within 2 minutes.
3. Between attempts the STATUS LED alternates red and green and after 20 seconds the FSR is reset, as indicated by a pulse of the RES LED and the clearing of the FSR ALARM LED.
4. After 4 failures within 2 minutes, the heater ceases operation, the controller locks out, the STATUS LED turns solid red, the run indications are removed and the alarm indications applied with the ALARM FSR LED alternating on and off.

### E.18 Reset

1. Prior to performing a reset:



**WARNING.** If you smell gas; Immediately extinguish all sources of ignition and turn off gas source.

Call qualified service technician to repair leak.

- 1.1 Toggle the selector switch to OFF.
- 1.2 Gain access to the controller by removing the electrical access panel.

**NOTE:** Note the status of the controller LEDs, contactor thermal overload relay reset (three phase models only), control panel circuit breaker, and motor circuit breaker. Connect a display module to the FSR and note the current and past fault histories.

- 1.3 Close any tripped or open breakers. Green means safe and red means danger circuit energized.
- 1.4 In the case of three phase models, if found tripped, reset the thermal overload relay located on the panel and connected to the contactor.



**WARNING.** Risk of cutting fingers or hand.

Open motor circuit breaker before opening combustion chamber access panel. Keep clear of fan.

- 1.5 In the case of single phase models, OPEN THE MOTOR CIRCUIT BREAKER. Remove the combustion chamber access panel and, if tripped, reset the thermal overload switch found on the motors junction box. Close the combustion chamber access panel and close the motor circuit breaker.

2. Press and release the controller reset.

## E.19 Energy Management System (EMS)

Adding the EMS allows a heater to operate automatically, or to act as a weather station when part of a network of heaters controlled by the Fastrax® RCMS.

The system includes a module, a precipitation detector, ambient temperature sensor, and rail thermostat. Once installed, the controller recognizes the EMS module and works in conjunction with it.

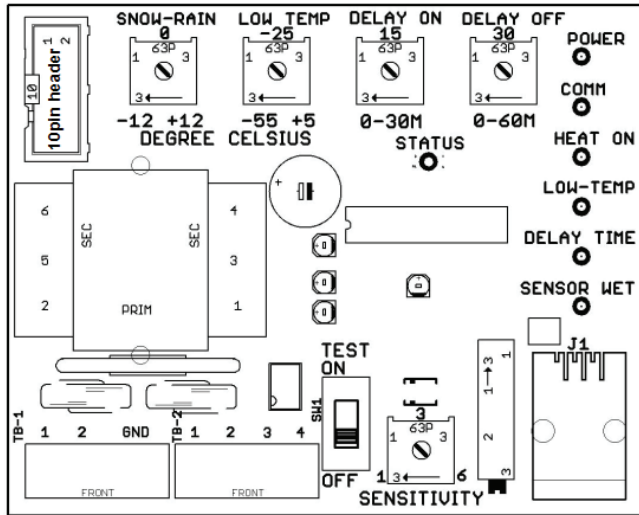

### Controls:

**NOTE:** These settings are true for AUTO mode only, with the exception of the TEST switch.

These settings are overridden when operated in REMOTE SCADA mode by the corresponding Fastrax® RCMS software parameter.

#### 1. SNOW-RAIN:

- 1.1 This dial adjusts the temperature set point between -12°C to +12°C.
- 1.2 Precipitation detected when the ambient temperature is below this set point is considered snow or above it is rain.

#### 2. LOW TEMP:

- 2.1 This dial adjusts the temperature set point between -55°C to +5°C.
- 2.2 The EMS will not request the heater to operate when the ambient temperature is below this set point and snow is detected.

#### 3. DELAY ON:

- 3.1 This dial sets the length of the delay, 0 to 30 minutes, before making the heater request.
- 3.2 When snow is sensed continuously for the duration of the delay on period the heater request is made. If at any time during the delay snow is not sensed the timer is reset.

#### 4. DELAY OFF:

- 4.1 This dial sets the length of the delay, 0 to 60 minutes, before removing the heater request.

4.2 When snow is no longer sensed the heater request is held for the duration of the timer. If at any time during the delay snow is sensed the timer is reset.

#### 5. TEST:

5.1 This switch simulates precipitation when ON. Used to test the module operation.

#### 6. SENSITIVITY:

6.1 This dial adjusts the precipitation detector sensitivity between the least, 1, and most, 6. For example, when set at 1 the detector has to be very wet to indicate precipitation.

#### 7. INDICATIONS:

7.1 On the module are a number of status LED's intended to aid the user's understanding of the state of operation. See table for full description.

Table 11 – Status LED's

LED Name	Description	State	Indication
STATUS	Processor status	Green with a red pulse	Processor functioning normally.
		Off	Processor failed.
		Solid green Solid red	
POWER	Power supply	On	Module energized.
COMM	Communications	Flashing	Indicates communications with controller.
HEAT ON	Heater request	On	EMS request to turn on heater.
LOW TEMP	Low Temperature	On	Ambient temperature is below set point. Heater will turn off or not turn on if requested.
		Off	
DELAY TIME	Delay Time	On with a pulse off	Delay active. Delay on when HEAT ON is off. Delay off when HEAT ON is on.
		Off with a pulse on	No delay.
SENSOR WET	Precipitation sensor wet	On	Precipitation above set point.

## E.20 Terminal Blocks

1. The controller interconnects with the control panel by means of 2 board level headers, TB-1 and TB-2, which accept wire harness plug connectors.

Table 12 – Terminal Blocks

Name	Description
TB-1	Precipitation detector 24V AC power supply
TB-2	Precipitation detector
JP1	Ambient air temperature sensor RJ11 header
10-Pin header*	EMS power and signal connection

\* Located in the upper left corner.

## E.21 Inputs and Outputs

1. **PRECIPITATION DETECTOR:** As its name implies, it senses precipitation that can be in the form of rain or snow.  
  
Snow landing on the detector's heated sensing head melts to form water drops. The 360° sensing surfaces detect blowing snow detect blowing snow as well as falling snow.  
  
See the installation section for mounting instructions. There are no adjustments on the detector itself. Sensitivity adjustments are made on the controller.
2. **AMBIENT TEMPERATURE SENSOR:** The ambient temperature sensor is mounted beneath the air intake hood. The controller compares the measured temperature to the SNOW-RAIN and the LOW TEMP set point.
3. **RAIL THERMOSTAT:** The rail thermostat optimizes fuel consumption and performance while the heater is requested. It functions independently of the EMS module, cycling the heater off when the rail temperatures rises above 9°C (49°F) then back on again once the temperature drops below 3°C (37°F).

2. The controller and EMS module connect via a ribbon cable that plugs into the 10-pin header found on each. The ambient temperature sensor connects via the RJ11 header.

## E.22 Soft Starter Operation and Parameters

Please refer to document THS3010-0621 for Soft Starter functional description and operation parameters.



**WARNING.** The soft starter's purpose is to reduce inrush and startup currents. It should not be used to adjust the blower speed. Operating the blower at a reduced speed may potentially create a safety hazard and/or damage to the equipment.

## E.23 Powered Run Indication Option

Powered run indication is an optional configuration available for those installations that require a 24V DC feedback signal to communicate heater operational status. See section 4.9, page 39 for a diagram of this wiring configuration

## F. TROUBLESHOOTING

\* The resets made by aggressive retry function are not described in the conditions.

\*\*Reset controller only after observing the condition of all status indicators then follow reset instructions.

Problem	Conditions*	Possible Cause	Remedy**	
Heater not running when expected. NO alarm indications. NO Soft Starter faults if equipped	No LEDs are on.	No line power.	<ul style="list-style-type: none"> <li>Verify panel and motor breaker are closed. (Ref. B.4 item 9)</li> <li>Verify supply voltage at power terminal block. (Ref. B.4 item 13)</li> </ul>	
	<ul style="list-style-type: none"> <li>Selector switch in manual position. (Ref. B.4 item 14)</li> <li>Controller and FSR POWER LEDs are on. (Ref. B.4 item 5 and 2.)</li> <li>RUN LED on. (Ref. E.2)</li> <li>Ambient temperature is above 3°C (37°F).</li> </ul>	Rail thermostat is closed. (Ref. B.3 item 29)	<ol style="list-style-type: none"> <li>Wait for ambient temperature to drop and the rail to cool.</li> <li>To verify heater operation, toggle selector switch OFF, then back to MANUAL. The heater starts, disregarding the rail thermostat status for the first 2 minutes of operation. (Ref. B.4 item 14)</li> </ol>	
	<ul style="list-style-type: none"> <li>Selector switch in REMOTE/AUTO. (Ref. B.4 item 14)</li> <li>EMS module installed. (Ref. B.4 item 7)</li> <li>Controller, EMS and FSR POWER LEDs are on. (Ref. B.4 item 5 and 2)</li> <li>Controller in AUTO mode. (Ref. E.2 and E.3 Table 5 - LEDs TD,RD,TX)</li> <li>Snowing.</li> </ul>	EMS module SNOW-RAIN set point below -1°C (30°F) and ambient temperature sensor disconnected.	Install ambient temperature sensor. Raise set point above 0°C (32°F). (Ref. E.19 and G.10.1 and .2)	
		SNOW-RAIN set point too low, i.e. 0°C (32°F).	Raise set point, i.e. 3°C (37°F). (Ref. E.19.1)	
		Precipitation detector damaged.	Replace detector head and/or cable.	
		Precipitation detector disconnected.	Verify connection to panel. (Ref. G.10.3)	
		Controller / EMS ribbon cable disconnected.	Verify presence of cable and connections. (Ref. G.10.1.5)	
		SENSITIVITY set point too low, i.e. 1	Raise set point to increase sensitivity. (Ref. E.19)	
		<ul style="list-style-type: none"> <li>Selector switch in REMOTE/AUTO. (Ref. B.4 item 14)</li> <li>EMS module installed. (Ref. B.4 item 7)</li> <li>Controller, EMS and FSR POWER LEDs are on. (Ref. B.4 item 5 and 2)</li> <li>Snowing.</li> <li>LOW TEMP LED on.</li> </ul>	Controller in AUTO mode and LOW TEMP set point too high.	<ul style="list-style-type: none"> <li>Verify set point. (Ref. E.19.2)</li> <li>For natural gas installations set to minimum, -55°C (-67°F).</li> <li>For LPG installations without tank heaters, set to -30 (-22°F).</li> </ul>
		<ul style="list-style-type: none"> <li>Selector switch in REMOTE/AUTO. (Ref. B.4 item 14)</li> <li>Controller, EMS and FSR POWER LEDs are on. (Ref. B.4 item 7)</li> </ul>	Controller in REMOTE SCADA mode and RCMS has not requested heater. (Ref. E.2 and E.3 Table 5 - LEDs TD,RD,TX)	Contact RCMS software operator and verify status.
Fan running. No heat. No alarm.	<ul style="list-style-type: none"> <li>Controller LEDs (Ref. B.4 item 5 and E.2)                             <ul style="list-style-type: none"> <li>POWER on.</li> <li>RUN on.</li> <li>HEAT on.</li> </ul> </li> <li>FSR LEDs (Ref. J.10)                             <ul style="list-style-type: none"> <li>Power on.</li> <li>PILOT on.</li> <li>HEAT on.</li> <li>MAIN on.</li> </ul> </li> </ul>	<ul style="list-style-type: none"> <li>Main ball valve closed.</li> <li>Pilot ball valve open.</li> </ul>	Open main ball valve. (Ref. B.5 item 11)	
		Main and/or safety solenoid valve not opening.	Verify operation of solenoid valves. (Ref. B5 Item 9)	
		<ul style="list-style-type: none"> <li>Cycling thermostat open. (Ref. E.3 Table 5 "CYCLING" LED)</li> </ul> (Heater will operate for 10 minutes before controller indicates alarm).	<ul style="list-style-type: none"> <li>Inspect cycling thermostat and wiring connections. (Ref. G.9)</li> <li>Replace failed thermostat. (Ref. I.1)</li> <li>Repair any damaged wiring.</li> <li>Connect any disconnected terminals.</li> </ul>	

Problem	Conditions*	Possible Cause	Remedy**
Heater operating but does not deliver adequate heat. No alarm.	Manifold pressure at maximum for propane.	Heater connected to natural gas.	The as delivered heater is set for LPG operation. Increase manifold pressure to within natural gas limits. (Ref. D.5)
	Manifold pressure at maximum for appropriate fuel.	Corrosion, dirt or other debris restricts burner orifices.	<ul style="list-style-type: none"> <li>Service burner. (Ref. J.16)</li> <li>Drill out each orifice with #47 drill (0.0785" diameter)</li> </ul>
		Duct system restricted.	Inspect tie duct or cross ducts for mud. (Ref. Manual 16359)
		(If Equipped) Soft Starter not configured correctly.	Configure Soft Starter operating parameters per Soft Starter Operation and Parameters Document No. THS3010-0621
	Gas manifold and supply pressure slowly drop while operating. (Ref. B.5 Item 7 and 10)	Vapour withdrawal causes refrigeration effect that lowers LPG tank pressure.	Remove snow accumulation on propane tanks.
Heater fails to start. Alarm indicated.	<ul style="list-style-type: none"> <li>Fan does not start.</li> <li>Controller LEDs (Ref. B.4 item 5 and E.2) <ul style="list-style-type: none"> <li>POWER on.</li> <li>ALARM red.</li> <li>AIR SW alternating.</li> </ul> </li> </ul>	Motor thermal overload relay open.	<ol style="list-style-type: none"> <li>240V single-phase models: Reset overload located on motor junction box. (Ref. E.18, 1.1 to 1.5)</li> <li>Three-phase models: Reset thermal overload relay located on control panel below contactor. (Ref. E.18.1.4)</li> </ol>
		Motor breaker open.	Close breaker.
		(If Equipped) Soft Starter fault	Refer to Soft Starter Operation and Parameters Document No. THS3010-0621
		<ul style="list-style-type: none"> <li>Air switch closed when expected open.</li> <li>Air switch jumped.</li> <li>Air switch frozen.</li> <li>Air switch out of calibration.</li> </ul>	Inspect air switch. (Ref. J.12)
			Remove jumper.
			Clear any ice or debris from air switch ports.
	Calibrate air switch. (Ref. J.13)		
	<ul style="list-style-type: none"> <li>Fan does not start.</li> <li>Controller LEDs (Ref. B.4 item 5 and E.2) <ul style="list-style-type: none"> <li>POWER on.</li> <li>ALARM red.</li> <li>AIR SW alternating.</li> </ul> </li> <li>High limit exceeded. (Ref. E.2 and E.3 Table 5 - LED HIGH LIM)</li> </ul>	Cycling thermostat loose inside sensor duct and high limit thermostat limit reached.	Fasten thermostats in place. (Ref. G.9 and I.1)
		Cycling thermostat leads shorted and high limit thermostat limit reached.	<ol style="list-style-type: none"> <li>Remove any test jumper shorting thermostat leads. (Ref. I.1 Figure 1)</li> <li>Verify leads are not shorted together between sensor box and control panel.</li> <li>Inspect wire insulation for damage and verify no shorts to ground.</li> <li>Verify manifold pressure is within nameplate limits. (Ref. B.5, H.2 Table 15)</li> </ol>
		High limit thermostat leads shorted.	<ol style="list-style-type: none"> <li>Remove any test jumper shorting thermostat leads. (Ref. I.1 Figure 1 and G.9)</li> <li>Verify leads are not shorted together between sensor box and control panel.</li> <li>Inspect wire insulation for damage and verify no shorts to ground.</li> <li>Verify interior of sensor box is dry.</li> <li>Seal or replace any damaged or missing gasket. Close lid.</li> </ol>

Problem	Conditions*	Possible Cause	Remedy**
Heater fails to start. Alarm indicated. (cont'd)	<ul style="list-style-type: none"> <li>Fan starts, runs briefly then stops.</li> <li>Controller LEDs (Ref. B.4 item 5 and E.2)               <ul style="list-style-type: none"> <li>POWER on.</li> <li>ALARM red.</li> <li>AIR SW alternating.</li> </ul> </li> </ul>	Heater NOT connected to duct system.	Complete heater installation.
		Air intake severely blocked.	Clear intake screen of blockage, i.e. ice, snow, paper. (Ref. B.3 item 12 and 14)
		Duct system blocked.	Remove any blockage such as mud, ice, or debris from: (Ref. Manual 16359) <ol style="list-style-type: none"> <li>Cross duct</li> <li>Tie duct</li> <li>Nozzles</li> <li>Rodent screens</li> </ol>
		Air switch fails to close when fan operating.	Calibrate air switch. See manual for instructions. (Ref. J.13)
		(If Equipped) Soft Starter not configured correctly.	Refer to Soft Starter Operation and Parameters Document No. THS3010-0621
	<ul style="list-style-type: none"> <li>Fan starts.</li> <li>Controller LEDs (Ref. B.4 item 5 and E.2)               <ul style="list-style-type: none"> <li>POWER on.</li> <li>MOTOR on.</li> <li>HEAT on.</li> </ul> </li> <li>FSR LEDs sequence: (Ref. J.10)               <ol style="list-style-type: none"> <li>POWER on.</li> <li>PILOT on.</li> <li>PILOT off.</li> <li>ALARM on.</li> </ol> </li> <li>Controller LEDs               <ul style="list-style-type: none"> <li>POWER on.</li> <li>ALARM red.</li> <li>FSR ALARM alternating.</li> </ul> </li> <li>Fan runs for post purge duration then stops.</li> </ul>	Inadequate gas pressure.	<ul style="list-style-type: none"> <li>Verify supply pressure is within nameplate rating. (Ref. B.5, H.2 Table 15)</li> <li>Verify pilot solenoid valve operation. (Ref. B.5 item 4)</li> <li>Verify manual pilot valve is open. Handle in line with body. (Ref. B.5 item 5)</li> </ul>
		Air in line.	Purge air from gas supply line. (Ref. G.6.5)
		No spark.	<ul style="list-style-type: none"> <li>Inspect igniter and ignition wire. (Ref. I.4)</li> <li>Replace any damaged items, fouled igniter, corroded wire or cracked boot.</li> </ul>
		Inadequate flame signal.	Inspect flame rod and wiring. (Ref. I.4) Replace any damaged items, fouled rod, corroded wire or cracked boot.
		<ul style="list-style-type: none"> <li>Controller LEDs (Ref. B.4 item 5 and E.2)               <ul style="list-style-type: none"> <li>POWER on.</li> <li>ALARM red.</li> <li>FSR CHECK alternating.</li> </ul> </li> </ul>	FSR missing.
FSR failed. Unable to energize solenoids.			Replace FSR. (Ref. B.4 item 2)
Open circuit between FSR 9-pin and main and safety solenoid.			Trace wiring. Repair damaged wires. Tighten any loose connections.
Heater starts, runs for 10 minutes with no heat, stops and then alarm indicated.	<ul style="list-style-type: none"> <li>Controller LEDs (Ref. B.4 item 5 and E.2)               <ul style="list-style-type: none"> <li>POWER on.</li> <li>ALARM red.</li> <li>CYCLING alternating.</li> </ul> </li> <li>FSR LED. (Ref. J.10)               <ul style="list-style-type: none"> <li>Power on.</li> </ul> </li> </ul>	Cycling thermostat failed open.	Replace thermostat. (Ref. I.1 Figure 1 and G.9) <b>NOTE:</b> If thermostat closes the alarm is cleared and the heater resumes normal operation.
		Cycling thermostat disconnected.	<ul style="list-style-type: none"> <li>Connect thermostat. (Ref. I.1 Figure 1 and G.9)</li> <li>Inspect for damaged wiring between control panel and thermostat box.</li> </ul>



Problem	Conditions*	Possible Cause	Remedy**
Heater cycles excessively. (Less than 30 second cycle time). No alarm.	<ul style="list-style-type: none"> <li>• Fan starts.</li> <li>• Controller LEDs (Ref. B.4 item 5 and E.2) <ul style="list-style-type: none"> <li>– POWER on.</li> <li>– MOTOR on.</li> <li>– HEAT on.</li> <li>– RUN IND on.</li> </ul> </li> <li>• FSR LEDs sequence (Ref. J.10) <ol style="list-style-type: none"> <li>1. PILOT on.</li> <li>2. HEAT on.</li> <li>3. MAIN on.</li> <li>4. HEAT off.</li> <li>5. MAIN off.</li> <li>6. PILOT off.</li> </ol> </li> <li>• FSR sequence repeats indefinitely.</li> </ul>	Marginal flame signal. PILOT signal above and MAIN signal below 1.2 micro amps.	<ul style="list-style-type: none"> <li>• Inspect flame rod and wiring. (Ref. I.4)</li> <li>• Replace any damaged items, fouled rod, corroded wire or cracked boot.</li> </ul>
		Manifold gas pressure set too high.	Reduce gas pressure to within nameplate setting. (Ref. B.5, H.2 Table 15)
		Air intake blocked.	Clear intake screen. (Ref. B.3 item 12 and 14)
		(If Equipped) Soft Starter not configured correctly.	Refer to Soft Starter Operation and Parameters Document No. THS3010-0621
		Duct system blocked.	Remove any blockage such as mud, ice, or debris from: (Ref. Manual 16359) <ol style="list-style-type: none"> <li>1. Cross duct.</li> <li>2. Tie duct.</li> <li>3. Nozzles.</li> <li>4. Rodent screens.</li> </ol>
Insufficient number of track duct vents open.	Open vents as per Switch Heater Duct Package, Installation instructions. 16359		
Heater starts and runs normally for a period of time then stops unexpectedly. Alarm indicated.	<ul style="list-style-type: none"> <li>• Controller LEDs (Ref. B.4 item 5 and E.2) <ul style="list-style-type: none"> <li>– POWER on.</li> <li>– ALARM red.</li> <li>– FSR ALARM alternating.</li> </ul> </li> <li>• FSR LEDs (Ref. J.10) <ul style="list-style-type: none"> <li>– POWER green.</li> <li>– ALARM red.</li> </ul> </li> </ul>	<ul style="list-style-type: none"> <li>• Marginal flame signal.</li> <li>• PILOT signal and MAIN signal occasionally dropping below 1.2 volts.</li> </ul>	<ul style="list-style-type: none"> <li>• Measure flame signal. (Ref. I.4)</li> <li>• Inspect flame rod and wiring.</li> <li>• Replace any damaged items, fouled rod, corroded wire, or cracked boot.</li> </ul>
		Manifold gas pressure set too high.	Reduce gas pressure to within nameplate rating. (Ref. B.5, H.2 Table 15)
		FSR reset module disconnected No retries possible.	Verify reset module is correctly plugged into FSR. (Ref. B.4 item 4)
		FSR detected fault.	<ul style="list-style-type: none"> <li>• Leave heater in ALARM. (Ref. C.2 Table 2)</li> <li>• Install FSR display module. Review fault history and refer to Honeywell documentation for further explanation.</li> </ul>
	Gas manifold and supply pressure slowly drop while operating. (Ref. B.5 Item 7 and 10)	Vapour withdrawal causes refrigeration effect to lower LPG tank pressure.	Remove snow accumulation on propane tanks.
Heater runs continuously. NO alarm.	Unable to stop the heater remotely. Mode selector switch in manual position. (Ref. B.4 item 14)	Heater accidentally left on.	Toggle selector switch to REMOTE/AUTO. (Ref. B.4 item 14)
	<ul style="list-style-type: none"> <li>• Mode selector switch in REMOTE/AUTO position.</li> <li>• Controller LEDs (Ref. B.4 item 5 and E.2) <ul style="list-style-type: none"> <li>– Power on.</li> <li>– MOTOR on.</li> <li>– HEAT on.</li> <li>– RUN on.</li> <li>– RTC on.</li> </ul> </li> </ul>	RTC has heater requested.	Notify RTC dispatcher.

## G. INSTALLATION



**WARNING.** Install and use Heater in accordance with owners manual and local codes.

In the absence of local codes, installation must comply with CAN/CSA-B149 Installation code and National Fuel Gas Code ANSI Z223.1 / NFPA 54, or Standard for the Storage and Handling of Liquefied Petroleum Gases, ANSI / NFPA 58.

For outdoor use only.

For use with ductwork only. Only duct work supplied by Thermon Heating Systems shall be used with the heater. Minimum clearance from combustibles: 2 inches.

Failure to comply with warnings may lead to serious personal injury or death.

To be installed in accordance with railroad and all applicable local governing regulations by persons approved by the railroad having authority.

Lift only in accordance with recognized safe lifting practices, as defined by applicable local laws and regulations.

Read and fully understand these instructions prior to attempting installation.

**NOTE:** Open combustion chamber access panel and remove loose packaged contents including large gasket kit, and if included with order, the precipitation detector, rail thermostat and flexible gas line.

### G.1 Overview

The following are general guidelines for the installation of typical HELLFIRE gas fired systems. They should be followed in conjunction with the specific site layout drawings provided with each heater.

Instructions are intended for track forces, construction, gas technicians, electricians, and signal maintainers.

### G.2 Recommended Tools

- A source of power to operate drills (portable generator)
- Impact Drill, 1/2" drive with 1/2", 9/16" and 3/4" sockets
- Drill, 3/8" drive
- Two 9/16" wrenches and/or socket wrench
- Lining and Tamping bars
- Sledge hammer
- Shovels
- Cold chisel and hammer
- 3" duckbill pliers
- Measuring tape
- 4 foot level
- Pipe wrenches
- Pipe thread sealant

### G.3 Site Preparation - Typical Clearances

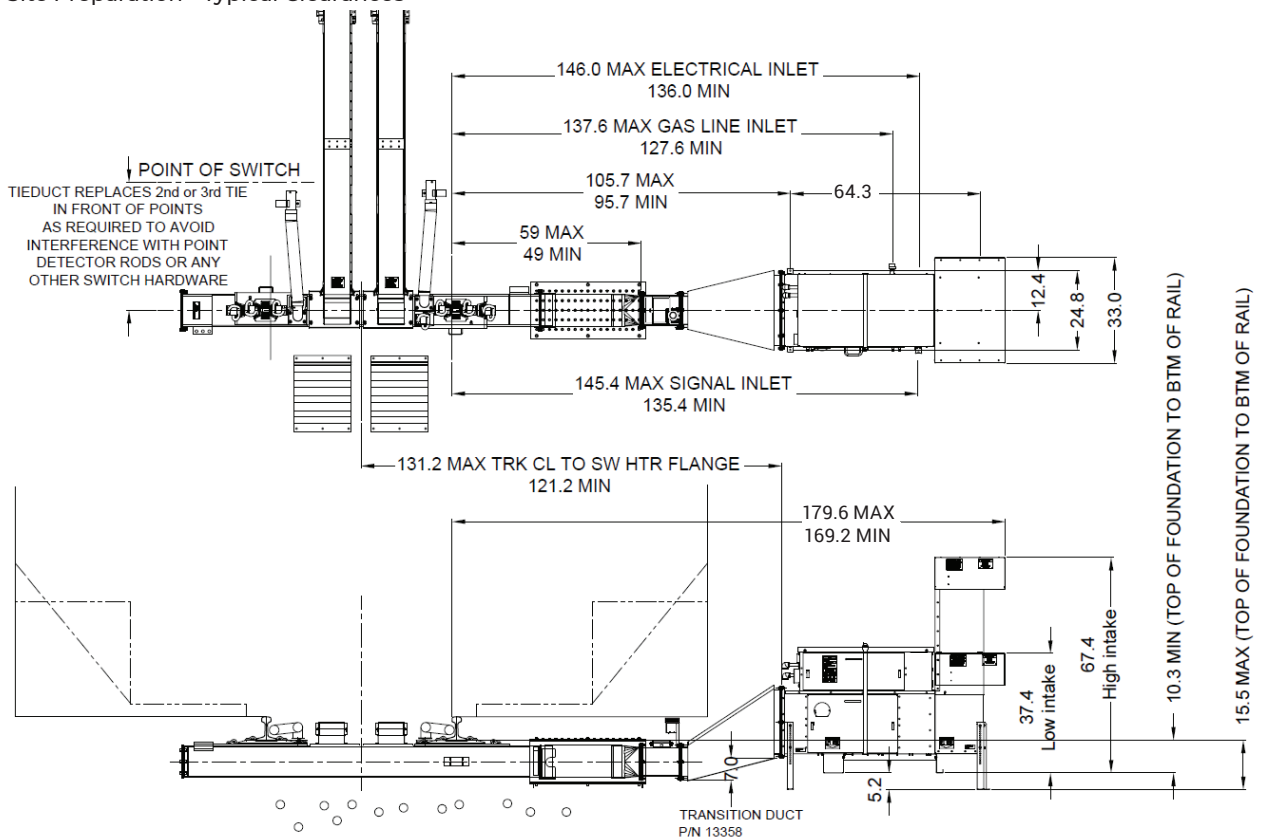

Figure 1 – 131" Clearance

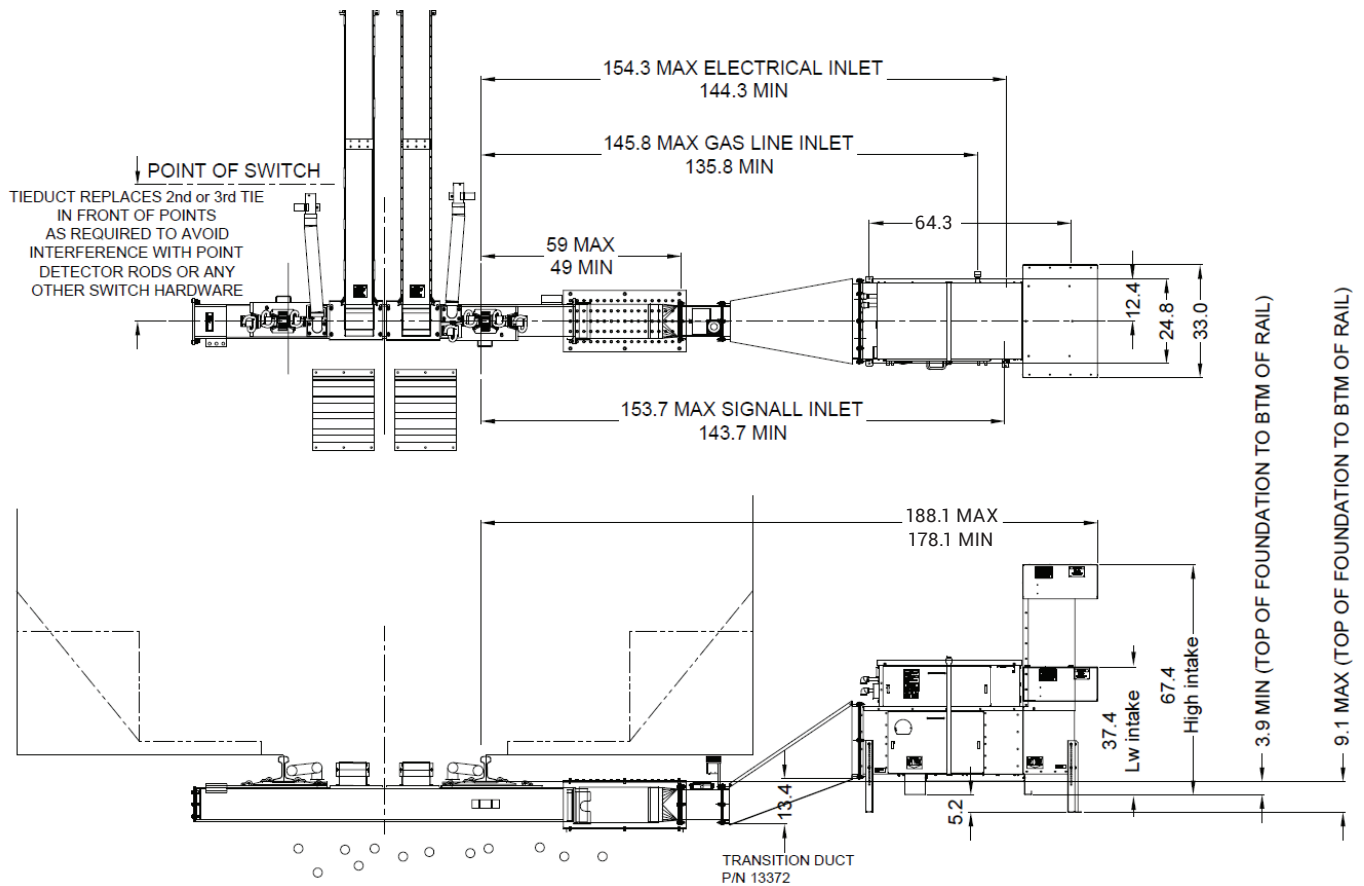

Figure 2 – 140" Clearance

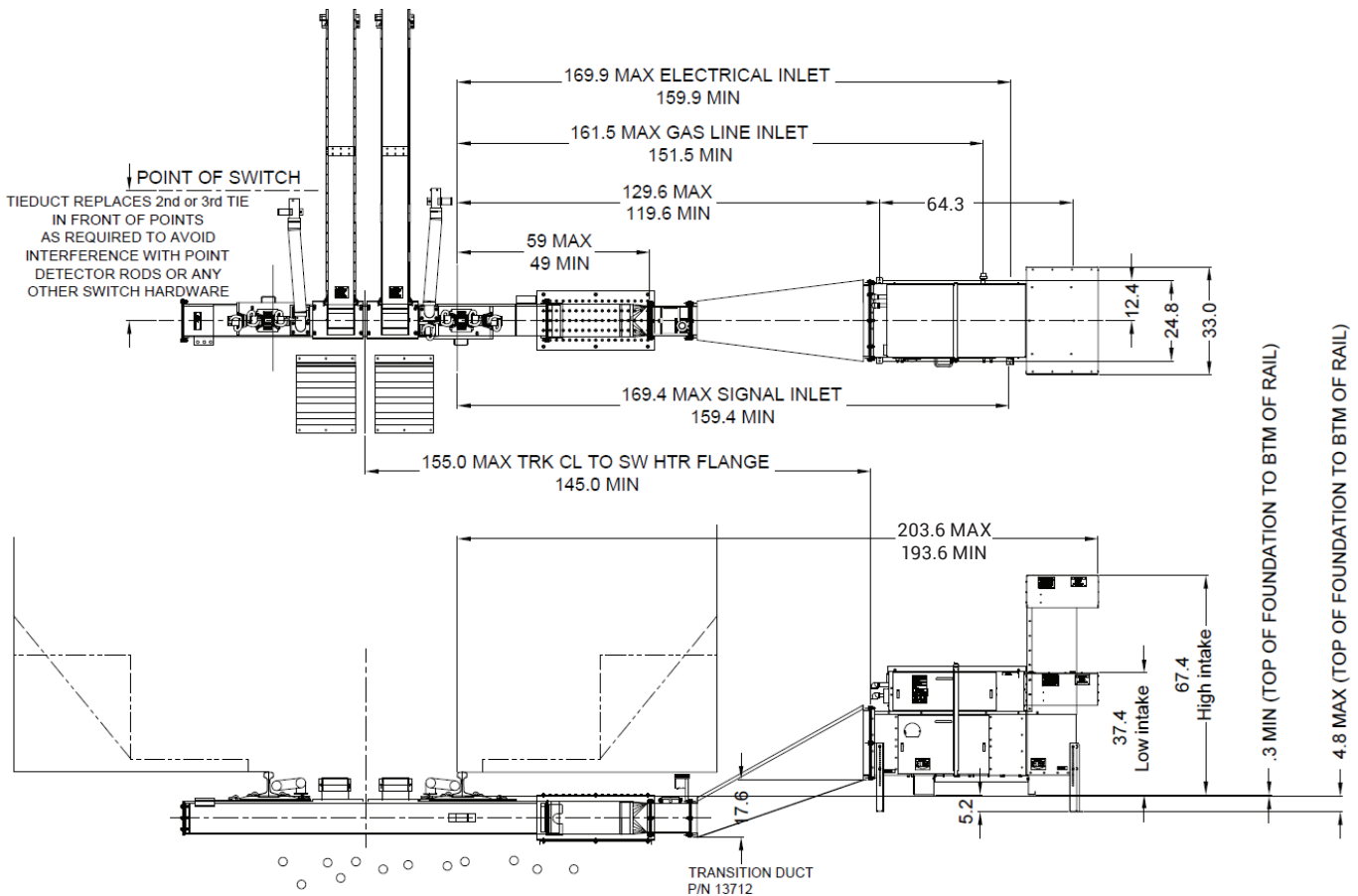

Figure 3 – 155" Clearance

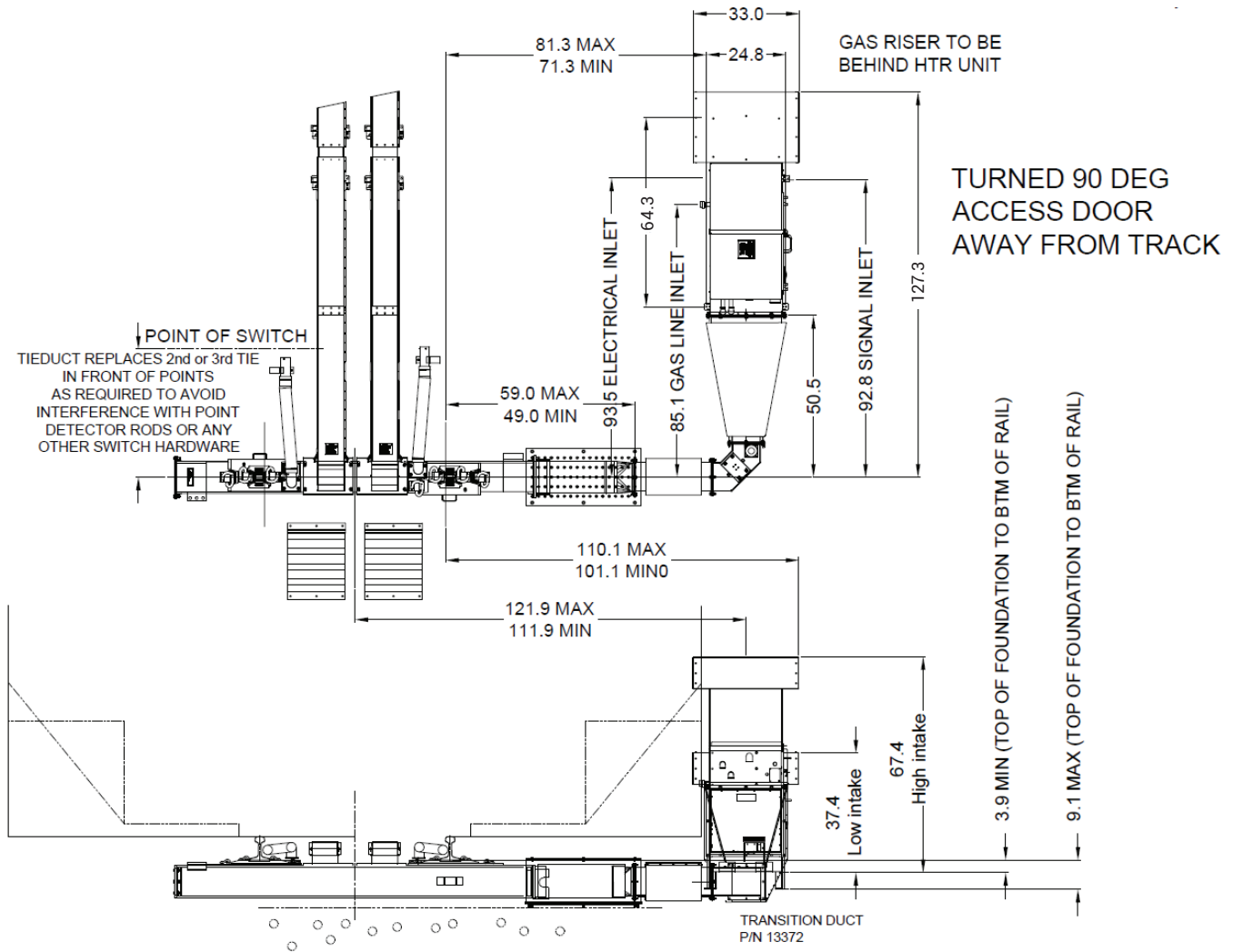

Figure 4 – 155" Clearance Turned 90 Degrees

## G.4 Site Preparation

1. Identify the tie to be replaced by the tie duct, or the crib for the crib ducts. Relative to the appropriate tie or crib, prepare a foundation for the heater with ties, concrete pad, or other suitable level mounting structure.
2. Note the location for the gas, electrical supply, and the signal cable lines.
3. Refer to the local gas and electrical authority in order to determine gas pipe and electrical line sizes.
4. At the heater, the gas inlet is a female 1" NPT pipe thread, the power terminal block accepts #14 - #2 AWG wire sizes, and the control and indicate wires connect to AAR 1/4" post terminals.

## G.5 Heater Installation

1. A typical complete system is composed of 4 parts, the heater, a transition duct, a tie duct or crib duct set, and a track duct set, each packaged separately.
2. Install the duct system components first, as per Switch Heater Duct Installation Manual, part number 16359.
3. Remove shipping cover attached to combustion chamber flange. Remove thermostat box from shipping cover and discard cover.
4. Remove banding strap securing access panels. Open combustion chamber access panel and remove loose packaged contents including large gasket kit, and if included with order, the precipitation detector, rail thermostat and flexible gas line.
5. Lift heater, (670 lbs.), using lift pockets and place on the foundation.
6. Level heater, adjust leveling legs, and align with the transition duct flange.
7. Fasten the heater and transition flanges together with the supplied gasket kit.
8. Fasten heater legs to foundation using lag screws supplied or suitable fasteners.

## G.6 Gas Supply Piping and Minimum Pressure Drop



**WARNING.** Personnel approved by the local gas authority must perform gas line connection.

1. Nominal supply pressure, 5 to 20 psi, with no more than 20% pressure drop, with all connected loads operating.
2. The minimum recommended supply pipe size is 1". Determine required pipe size based on supply pressure, length of run, and the total demand of all connected loads.



**CAUTION.** Undersized gas piping will affect the light off reliability of any connected appliance.

3. The heater is supplied with an internally mounted supply regulator and an external dirt trap. The dirt trap inlet has a 1" NPT female fitting.
4. Install a flexible gas line between the customer supplied gas line and the dirt trap inlet.

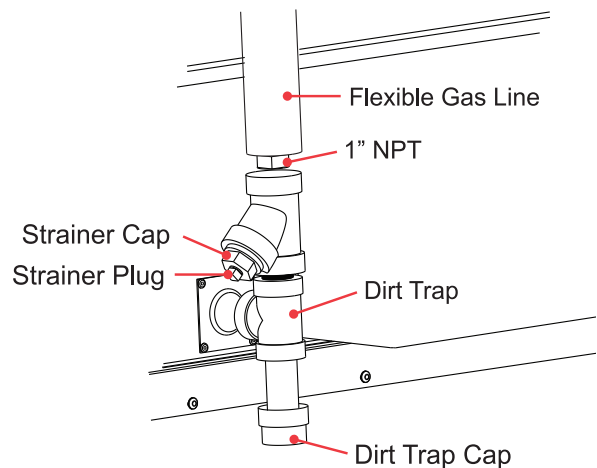

5. Prior to firing the heater, bleed the gas lines of any air and dirt through the opened dirt trap.
6. Reinstall the dirt trap cap and check all joints for leaks.

## G.7 Electrical Power Connections



**WARNING.** Risk of electrical shock or electrocution.

Disconnect power at service.

Heaters must be wired in accordance with local electrical codes.

The electrical grounding of the appliance shall be in compliance with CSA C22.1, Canadian electrical code, Part 1, or National Electrical Code, ANSI/NFPA 70.

Personnel approved by the local electrical authority must perform electrical power connection.

### IMPORTANT NOTE

#### Surge Protection Recommendations

This switch heater utilizes a number of processor-based control systems, all of which are susceptible to damage from lightning and other electrical surges. While every effort has been made to ensure that the control systems have been adequately 'hardened' Thermon Heating Systems, Inc's surge mitigation efforts can only be effective if ALL external remote circuits connecting to the switch heater have been protected by primary surge protection devices in accordance with the following generally accepted requirements for surge protection of wayside signal equipment:

- Provide primary surge protection devices (standard signal air gap arresters) on all external switch heater control I/O circuits. These arresters should be located "upstream" of the switch heater housing (within the signal housing, which interfaces to the switch heater). It is essential to protect ALL circuits entering or leaving the signal housing.
- Provide a primary surge protection device (commercial high capacity MOV type) on the external switch heater ac power feed. This surge protection device should be located "upstream" of the switch heater in conjunction with the electrical service entrance panel and main disconnect. Observe primary surge protector manufacturer's instructions for installation and circuit breaker protection (if required).

- Grounding of the switch heater metal housing as well as the ground terminals of the primary arresters is essential for personnel protection as well as surge protection. Grounding rods and conductors must be installed in accordance with the AREMA Signal Manual of Recommended Practice.
- Primary surge protection must be installed in accordance with the AREMA Signal Manual of Recommended Practice.

### G.8 Power Connections

1. Remove control cabinet lid and electrical sub component cover plate.
2. Remove knockout plug. For conduit larger than ½", punch an appropriate size hole.
3. Terminate power cables to terminal block and ground wire to grounding stud.

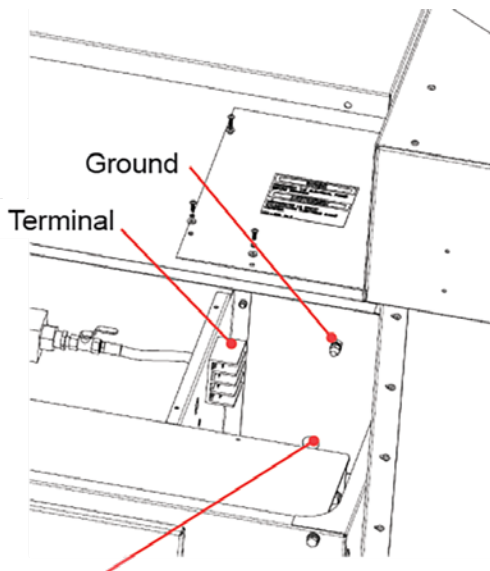

Punch appropriate size hole for power conduit

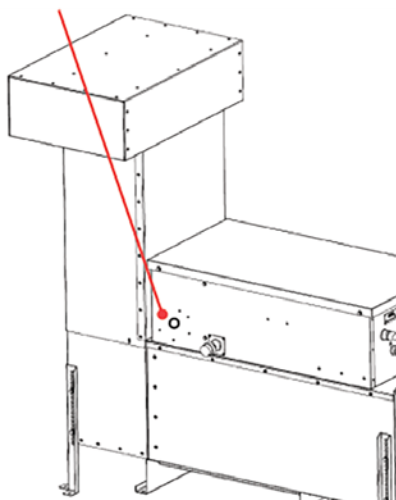

### 4. Three Phase Systems Only



**CAUTION.** For three phase systems only - verify correct fan rotation.

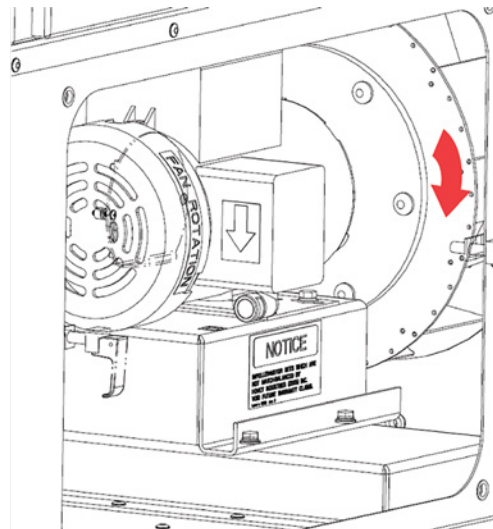

- 4.1 Three phase systems only – Place selector switch in OFF position.
- 4.2 Turn service power on and close the motor breaker. Open the combustion chamber access panel.
- 4.3 Note the fan rotation arrow.



**WARNING.** Risk of cutting fingers or hand. Keep hands clear of fan.

- 4.4 Manually close the motor contactor momentarily, enough to spin the motor. Verify the correct rotation. If the rotation needs to be reversed, open the service breaker and interchange two of the supply phase wires at the heaters power terminal block.

5. Conductor Sizing

5.1 Using the following table to aid in the selection of the appropriate size conductors between the heater and service.

Table 13 – Conductor Sizing

Voltage	Phase	Current	Circuit Breaker <sup>1</sup>	Wire Size									
				#10		#8		#6		#4		#2	
				Maximum Distance <sup>2,3</sup>									
				m	ft	m	ft	m	ft	m	ft	m	ft
240	1	27	40	65	215	104	342	166	544	264	868	419	1375
208	3	15.2	30	116	382	185	609	295	968	470	1543	745	2445
460	3	7	15	560	1838	892	2925	1417	4649	2259	7410	3580	11745
575	3	5.6	15	875	2873	1393	4571	2214	7264	3530	11579	5595	18352

1 As per Canadian Electrical Code, Part 1.

2 Assumed voltage drop of 5%.

3 Allowable voltage drop to be determined by local authority.

6. Local Safety Grounding

6.1 The service ground electrically grounds the heater. If a local safety ground is required, drive in at least one ground rod and connect it with a suitably sized stranded copper conductor, of at least #8 AWG, to one of the leveling leg bolts.

7. Signal and Communications Connections

7.1 Use the 1/2" conduit knockout, or punch a suitable size hole for the signal cable.

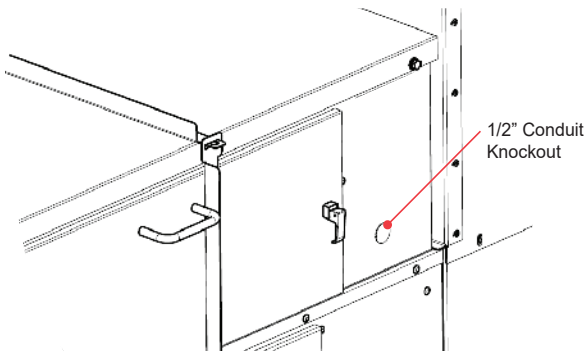

7.2 All signal and communications connections are made to the 1/4" AAR control and indicate terminal block. The terminals are labeled A1 to A12.

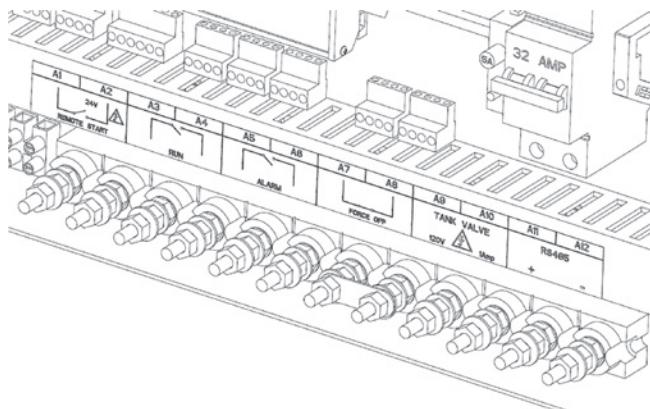

Table 14 – Terminals

Terminals	Label	Description
A1 - A2	REMOTE START	A contact closure across these terminals starts the heater when the heater is in REMOTE RTC mode..
A3 - A4	RUN	24 VDC is supplied to provide run indication.
A5 - A6	ALARM	Dry contact closes to provide alarm indication.
A7 - A8	FORCE OFF	Default is closed. If FORCE OFF function is desired, remove shorting link and replace with customer supplied relay contact. Open contact disables heater.
A9 - A10	TANK VALVE	These terminals are intended to operate a 120V AC gas supply solenoid shut off valve. They energize when the motor contact closes.
A11	RS-485 (+)	Communications, RS-485 positive terminal.
A12	RS-485 (-)	Communications, RS-485 negative terminal.

## G.9 Thermostat Installation

Install the thermostat sensor box as per instructions below:

1. Remove combustion chamber shipping cover.
2. Detach thermostat box from shipping cover.
3. Secure thermostats to the duct using SST machine screws - ensure colour coded wires match.
4. Secure thermostat box to the sensor duct as depicted, with the ground wire under the head of a bolt and washers.
5. Install thermostat cover to box using hardware supplied.

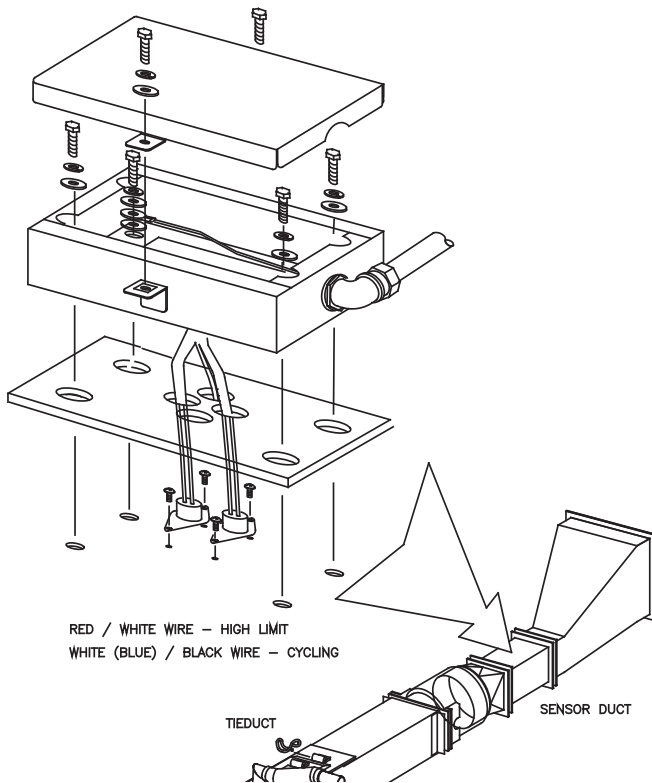

## G.10 Energy Management System (EMS) Options

1. EMS Module
  - 1.1 The module mounts onto the DIN rail to the right of the controller in the space provided, and a communication cable connects the two together.

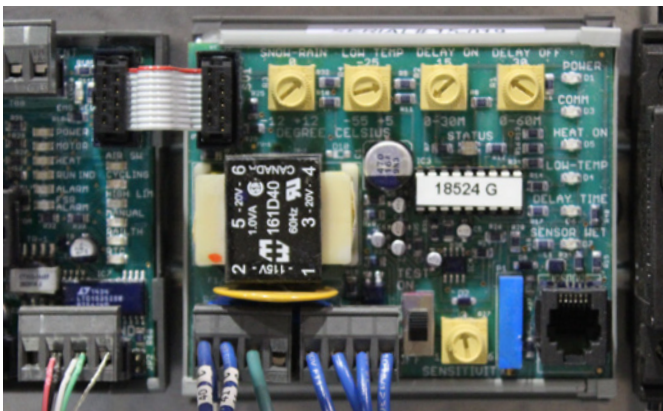

- 1.2 As received panel with no EMS module.

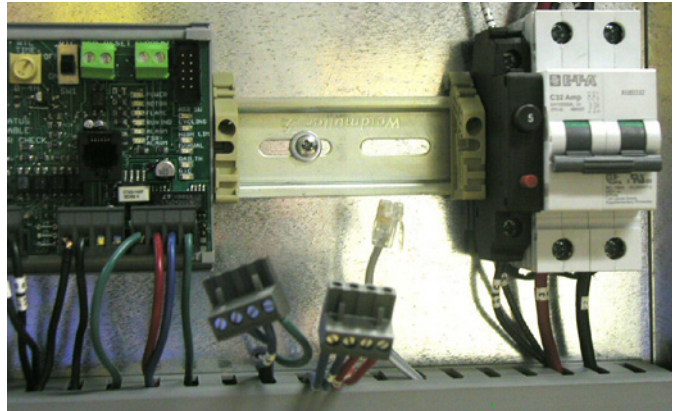

- 1.3 Remove the stops holding the controller and the circuit breaker.
- 1.4 Install module onto DIN rail. Plug in 4-pin connectors and ambient temperature RJ11 jack.

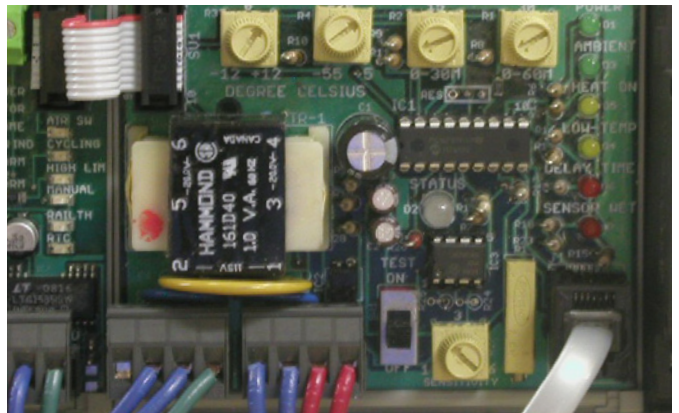

- 1.5 Connect module to controller with supplied ribbon cable.

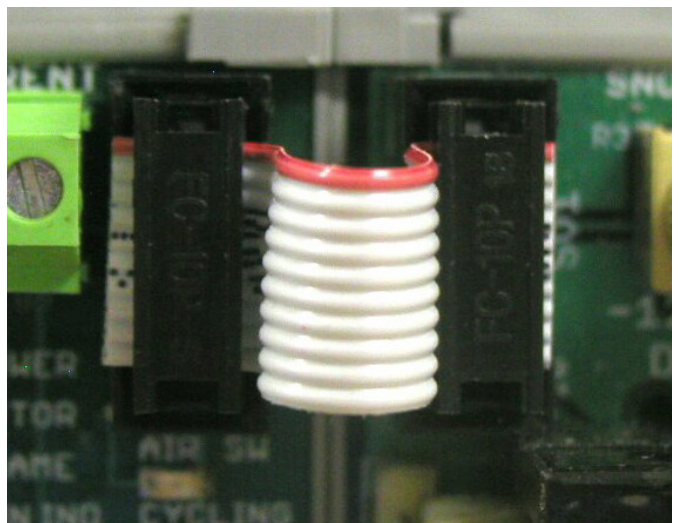

**NOTE:** The precipitation detection and ambient temperature sensor options require the EMS module be installed.



## 2. Ambient Temperature Sensor

To route the sensor cable it is necessary to remove the air intake.

- 2.1 Remove the 4 screws holding the extension to the elbow. Leave the hood and extension fastened together. Remove intake.
- 2.2 Mount the ambient temperature sensor inside the air intake hood with a pair of 8-32 screws, nuts and washers, in the location shown.
- 2.3 Route the cable through the screen, and down the inside of the extension. Cut the diaphragm grommet at the bottom of the extension and push the connector and cable through, as shown.
- 2.4 Cut the diaphragm grommet on the control cabinet and run the cable through. Insert grommet and cable into hole.
- 2.5 Reassemble the intake, draw the excess cable into the control cabinet and connect it to the mating connector on the EMS module.

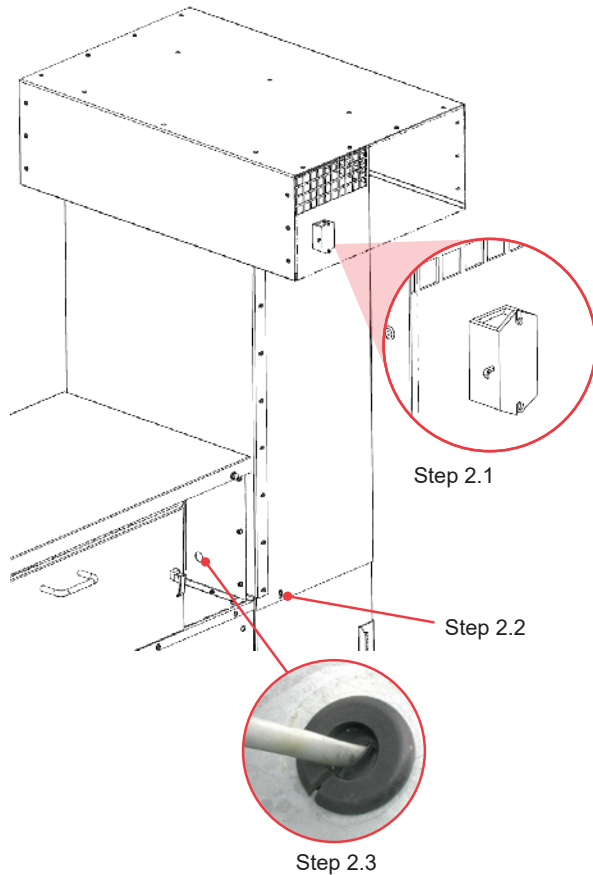

## 3. Precipitation Indicator

Remove the plug from the top hole marked 'Precipitation Sensor'. Pass the 4-pin connector through the hole, install lock nut and tighten.



- 3.1 Insert jack into mating connector.

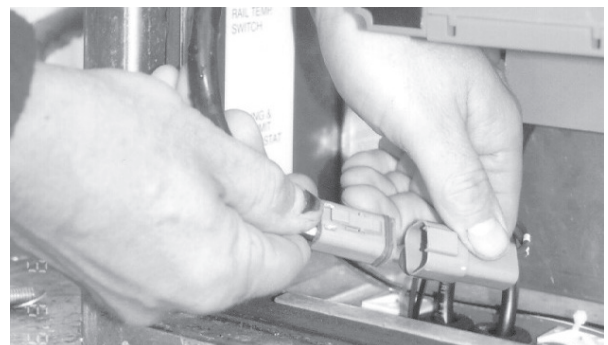

- 3.2 Mount the detector on the transition duct to sensor duct flange facing forward as shown. Heat from the duct will keep it clear of ice and snow build up.



4. Rail Thermostat

Mount the rail thermostat on the field or gage side of the stock rail ahead of the points and tie duct, as shown. Select a location shaded from the sun. Provide strain relief in the cable, by leaving adequate slack, as shown, to allow for rail pumping.



Remove the yellow shim washers when installed on 115 lb rail or lighter. Loosen the two mounting bolts and attach the rail thermostat to the rail flange by tapping it on with a hammer. Once in place tighten mounting bolts to maximize grip.

- 4.1 Remove the four (4) Phillips screws, the cover, and the plug from the hole in the rail temperature surge protection box.

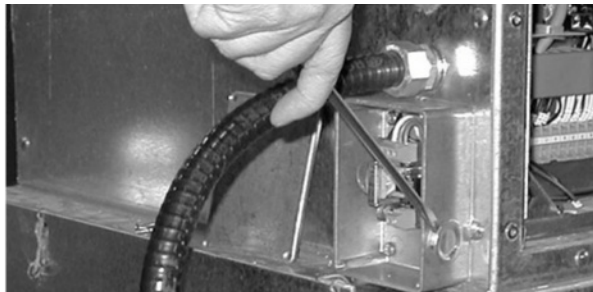

- 4.2 Pass the two (2) wires from the rail temperature sensor through the hole, install the locknut and tighten.

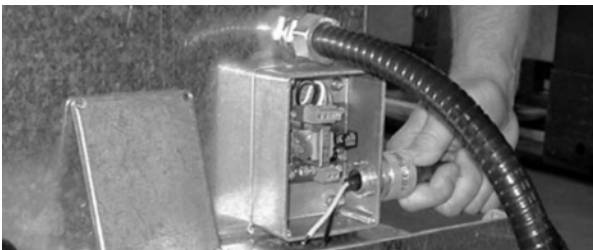

- 4.3 Insert, one each of the bared wires into the two terminals on the surge suppression circuit board, and tighten. There is no polarity.

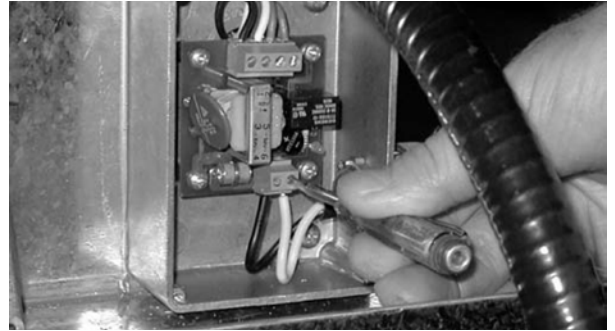

- 4.4 Replace the cover, and tighten the four (4) Phillips screws.



- 4.5 Connect the surge isolator two pin connector with the mating plug located inside the electrical component area, hanging immediately under the FSR.



## G.11 Inspection and Commissioning

Once the installation is complete review it against the following checklist.

### Point Nozzles

- Installed.
- Directed at, and tip within 2" to 6" of points, and clear of rail head by 2.0".
- Rodent screens installed between duct and silicone gasket under adaptor collars.
- Electrical isolation shoulder washers installed.

### Track Duct

- Installed.
- Rodent screens installed between duct and silicone gasket under elbows.
- Access joint gap of 3".
- Appropriate vents open and directing air at switch plates and rods. Keep all openings closed between the ducts, except where the switch rods are located. Open vent openings no more than ¼".
- Ductwork below top of rail and not interfering with switch operation.
- Track duct deflectors installed, 18" wide at points protecting point nozzles and track duct and 8" at heel protecting track duct.

### Tie Duct

- All clips and insulators installed.
- Flex ducts and ballast retainer installed.

### Electrical Power

- Voltage between 85% and 115% of nominal voltage with all connected loads operating.
- Ground installed.

### Gas System

- Supply pressure at rated supply pressure with all connected loads operating.
- Gas supply leak tested.

### Heater

- Level.
- Heater functions in "Manual".
- "Run" indication function. With the heater running, the contact between terminals A3 and A4 will close. Check for continuity. If equipped with optional powered run indication, check for 24 VDC between terminals A3 and A4.
- "Alarm indication function. Put the heater into alarm by turning the gas supply off. The heater retries three times. Then the FSR will indicate alarm, and the alarm LED on the controller will light. The contact between terminals A5 and A6 will close. Check for continuity.
- Heater functions in "Remote" control. Toggle mode selector switch to "REMOTE/AUTO". If connected to dispatch, have dispatch start heater.
- With heater running for at least 15 minutes, temperature at closest point nozzle is 93°C - 121°C (200°F - 250°F) above ambient.

### EMS

- Precipitation detector installed on the transition duct, as low to the ground and as close to the switch as possible, and in the heated zone.
- Drop snow (or water) on precipitation detector sensing grid. Snow melts and "SENSOR WET" LED lights on EMS module.
- Ambient temperature sensor installed.
- Raise "SNOW-RAIN" set point, if required, above the ambient temperature. The "AMBIENT" LED lights.
- Rail thermostat, if supplied, installed on rail flange.
- Return set points to desired settings.

# H. HEATER SPECIFICATIONS

## H.1 Performance

- Clears ice and snow from switches with up to 40-foot points or longer. (Recommended heating, 10,000 to 22,500 BTU/hr per foot of track coverage, based on severity of local climate).
- Up to 3000 scfm of heated air delivered via a duct system, point nozzles and track duct vents.
- Heat output range 204,000 to 900,000 BTU/hr LPG or 230,000 to 900,000 BTU/hr NG, field adjustable.
- Output air temperature limited to 193°C (380°F) maximum.
- Burner efficiency, minimum 95%.
- SCADA network connectivity via RS-485 communications port.

## H.2 Gas Firing

Table 15 – Gas Firing

	Propane	Natural Gas
Input rating, BTU/hr (kW)	204,000 - 900,000 (60 - 264)	230,000 - 900,000 (67 - 264)
Manifold pressure, inches of water (kPa)	5.0 - 11.5 (1.25 - 2.86))	6.0 - 18.0 (1.49 - 4.48)
Supply pressure, psig <sup>1,2</sup> (kPa)	5 - 20 (34 - 138)	

1 With no more than 20% pressure drop, with all connected loads operating.

2 Inlet gas fitting, 1" NPT female.

## H.3 Gas Conversion

1. Heaters are factory set for use with propane gas.
2. To convert to natural gas adjust gas pressure to within nameplate rating. If higher output is required, select and change the main gas pressure regulator spring, with one supplied separately, and adjust within specifications detailed above. Affix separate gas type plate supplied. Reverse procedure to change back to original gas.

## H.4 Electrical

Table 16 – Electrical

Voltage	Phase	Wiring	Running Amps <sup>1,2,3</sup>	Frequency (Hz)
240	1	3 wire, L1, L2, N	27	60
208	3	4 wire, L1, L2, L3, N	15.2	60
460	3	3 wire, L1, L2, L3	7	60
575	3	3 wire, L1, L2, L3	5.6	60

1. On start up, peak in rush current is usually 6-8 times the running amp unless equipped with soft starter.
2. Current drops to running amperage after 4 seconds. If equipped with soft starter, starting current should remain close to running current. Startup should take approximately 20 seconds for the motor to reach full speed.
3. Five horsepower fan drive motor for all configurations.

## H.5 Controls

Table 17 – Controls

Feature	Description
Remote Start	Provide dry contact, rated for 24V AC 0.5 amp.
Run Indication	Standard - Max. 240V AC or 24V DC, 10 amp. Optional Powered Run Indication - 24V DC, up to 420 mA
Alarm Indication Contacts	Maximum 240V AC or 24V DC, 10 amp.
Magnetic Motor Starter	Coil voltage 120V AC.
Motor Thermal Overload Protection	Single phase, reset located on motor. Three phase, thermal overload relay fastened to contactor.
Optional Soft Starter (Replaces Magnetic motor starter and thermal overload.	Reduces startup current. Converts 240V AC Single Phase to 240V AC Three Phase.
Thermostatically limited output air temperature, cycling	193°C (380°F) maximum, open on rise, automatic reset.
Thermostatically limited output air temperature, high limit	216°C (420°F) maximum, close on rise, manual reset.
Flame Safety Relay	Honeywell Burner Control, RM7895A, continuous pilot.
SCADA	RS-485 MODBUS RTU
Rail Thermostat	9°C (49°F) close on rise, automatic reset.

## H.6 Wiring Terminations

Table 18 – Wiring Terminations

Function	Size Range	Termination Type
Power	#14 to #2 AWG copper	Barrier Terminal Block, Tubular with clamping screw.
Control	#22 to #4 AWG	AAR terminal posts, #14-24 UNS
RS-485 Communications	#22 to #4 AWG or #26-#12 AWG	AAR terminal posts, #14-24 UNS or PCB plug in connector. Tubular with clamping screw.

## H.7 Safety Features

1. **Air Pressure:** Upon start up and request for heat, the trial for ignition does not start until proper air pressure is developed. The burner is extinguished immediately if air pressure moves out of range.
2. **High Temperature Limit:** In the event the heated air temperature exceeds 216°C (420°F), the burner is extinguished, the heater is shut down and locked out. A manual reset is required.

3. Loss of Flame: If, upon start up and request for heat, the trial for ignition fails to light the burner, or the flame signal is lost while heating, the burner is extinguished immediately.

4. Ductwork Electrical Isolation: As per, AAR standards part 14.5.1D, "Recommended Design Criteria for Assembly and Test of Insulated Track Fittings, Dielectric Requirements", ducting and nozzle connections are electrically isolated to withstand a maximum of 3000V AC for 60 seconds to eliminate possible interference with track circuits.

## H.8 Controller Terminal Identification

Table 19 – Controller Terminal Identification

Terminal Block	PIN	Input	Output	Power Source
TB1	1	120V AC		120V AC
	2	Neutral		
	3		Motor Contactor	
	4		Neutral	
	5		120V AC Transformer	
	6		Neutral	
TB2	1	120V AC		120V AC
	2		FSR Request	120V AC
	3	24V AC		24V AC From Transformer
	4	24V AC		24V AC From Transformer
TB3	1		Run Indication	Dry Relay Contact
	2		Run Indication	Dry Relay Contact
	3		Alarm Indication	Dry Relay Contact
	4		Alarm Indication	Dry Relay Contact
TB4	1	Rail Thermostat		24V AC
	2		24V AC	
	3	RTC A1-A2		
	4		24V AC	
	5	Manual		
	6	Enable		
TB5	1	Air Switch		120V AC
	2		Neutral	
	3	ALRM FSR		
	4	Valve Feedback		
TB6	1		24V AC	24V AC
	2	Cycling SW		
	3		24V AC	
	4	High Limit SW		
TB7	1		GND	GND
	2	POS Signal RS 485		Communication
	3	NEG Signal RS 485		Communication
	4		GND	GND
TB8	1	FSR Reset +		From FSR
	2	FSR Reset -		From FSR
	3	Current		Current Transformer
	4	Current		Current Transformer

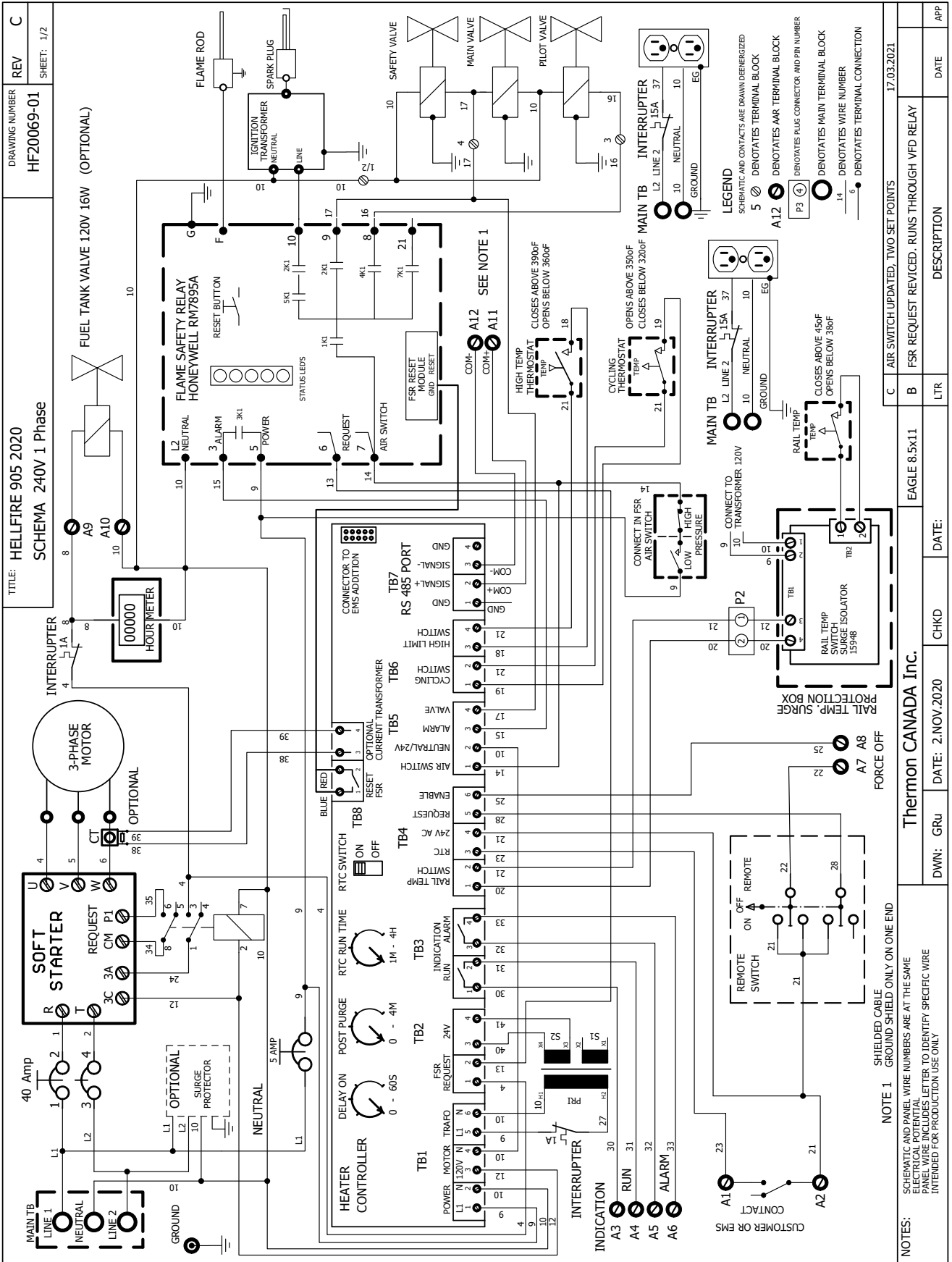

### EMS BOARD OPTION PRINCIPLE CONNECTION

SCHEMATIC AND PANEL WIRE NUMBERS ARE AT THE SAME ELECTRICAL POTENTIAL  
 PANEL WIRE INCLUDES LETTER TO IDENTIFY SPECIFIC WIRE  
 INTENDED FOR PRODUCTION USE ONLY

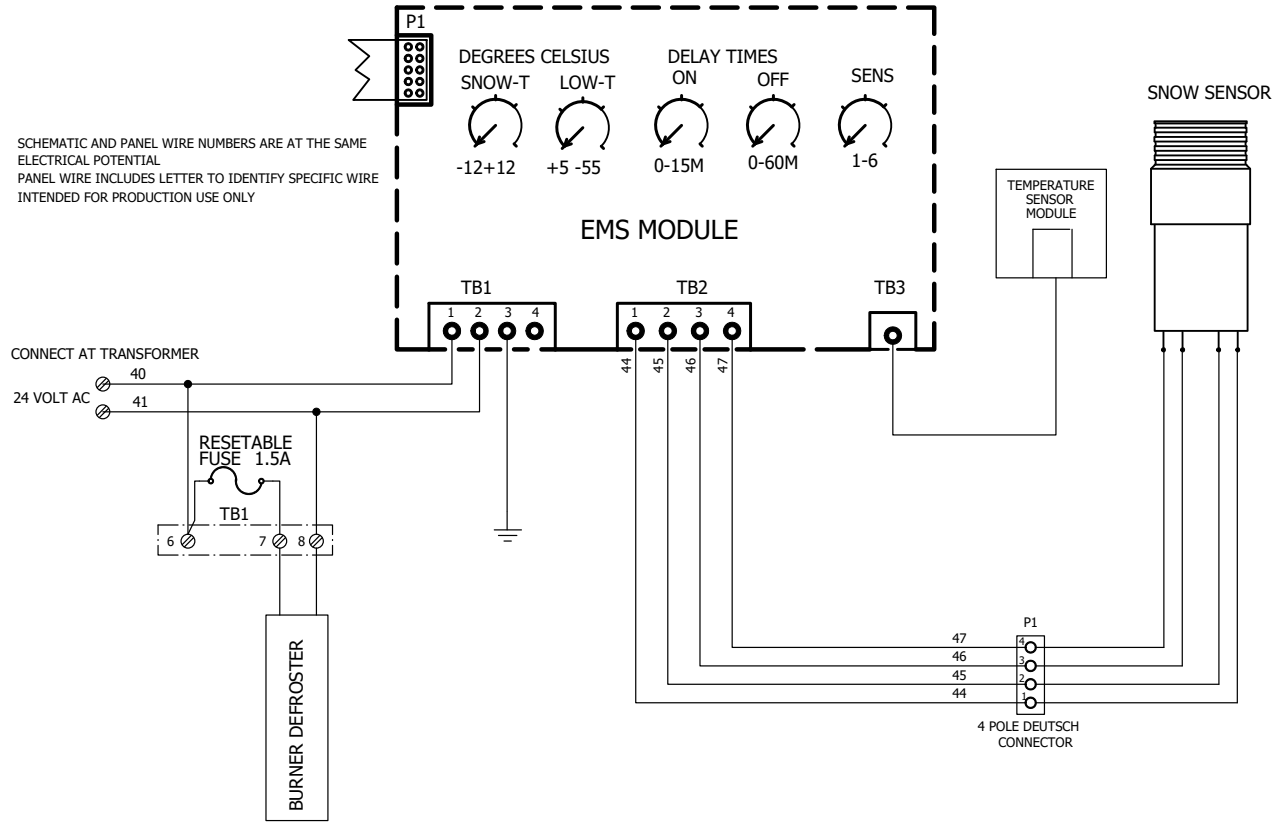

### POWERED RUN INDICATION PRINCIPLE SCHEMATIC

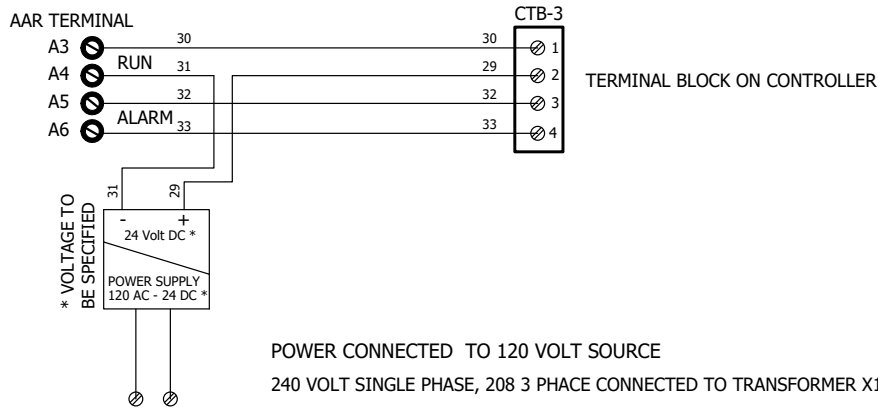

POWER CONNECTED TO 120 VOLT SOURCE  
 240 VOLT SINGLE PHASE, 208 3 PHASE CONNECTED TO TRANSFORMER X1, WIRE # 48 AND X2, WIRE # 84  
 440 AND 600 VOLT 3 PHASE CONNECTED TO CONTROLLER TERMINAL 1  
 CONTROL BOARD TB1-5, WIRE # 9 AND CONTROL BOARD TB1-6, WIRE # 10.

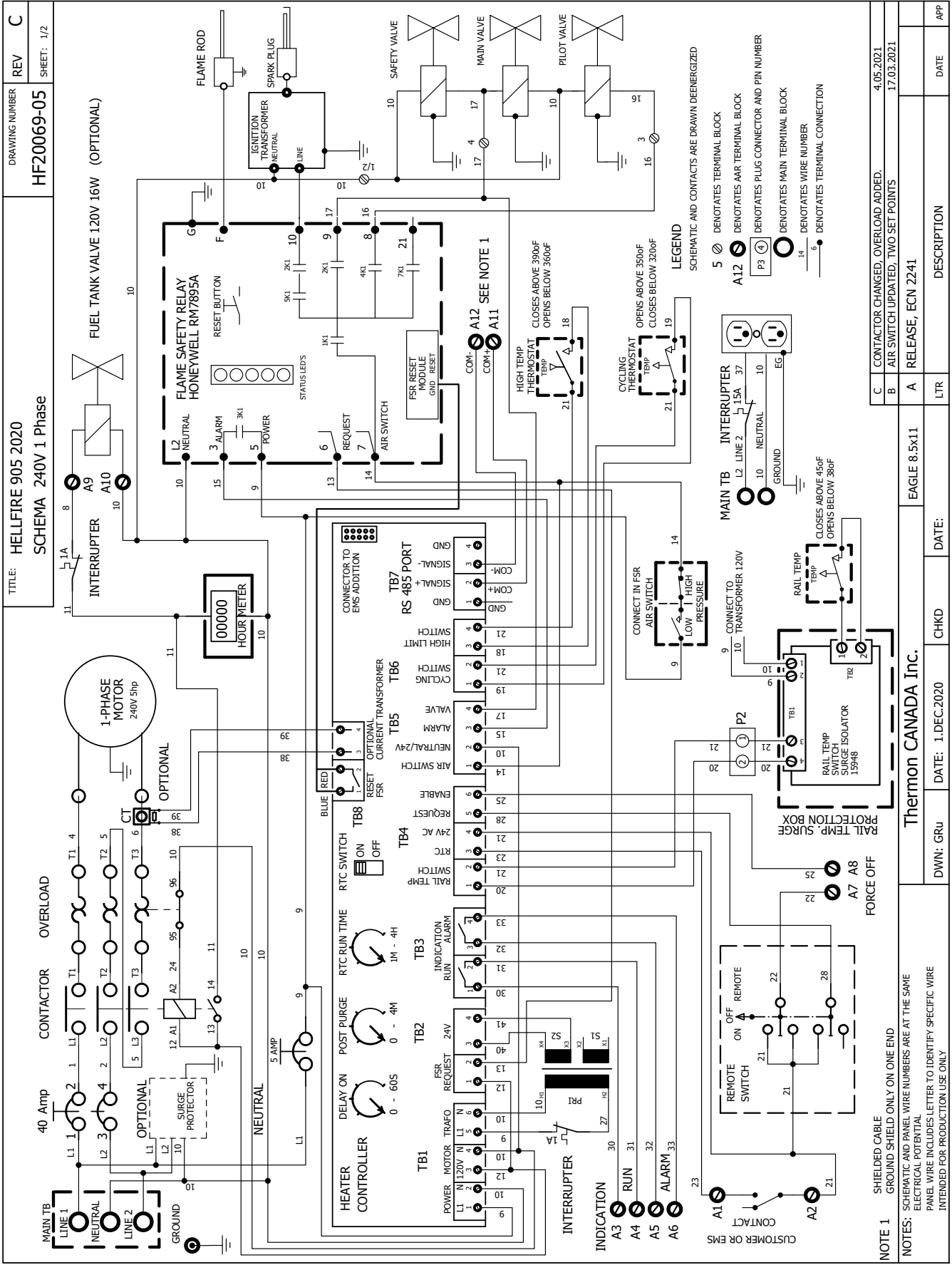

Thermon CANADA Inc.

DWN: GRU DATE: 1.DEC.2020

CHKD

EAGLE 8.5x11

DESCRIPTION

DATE

APP



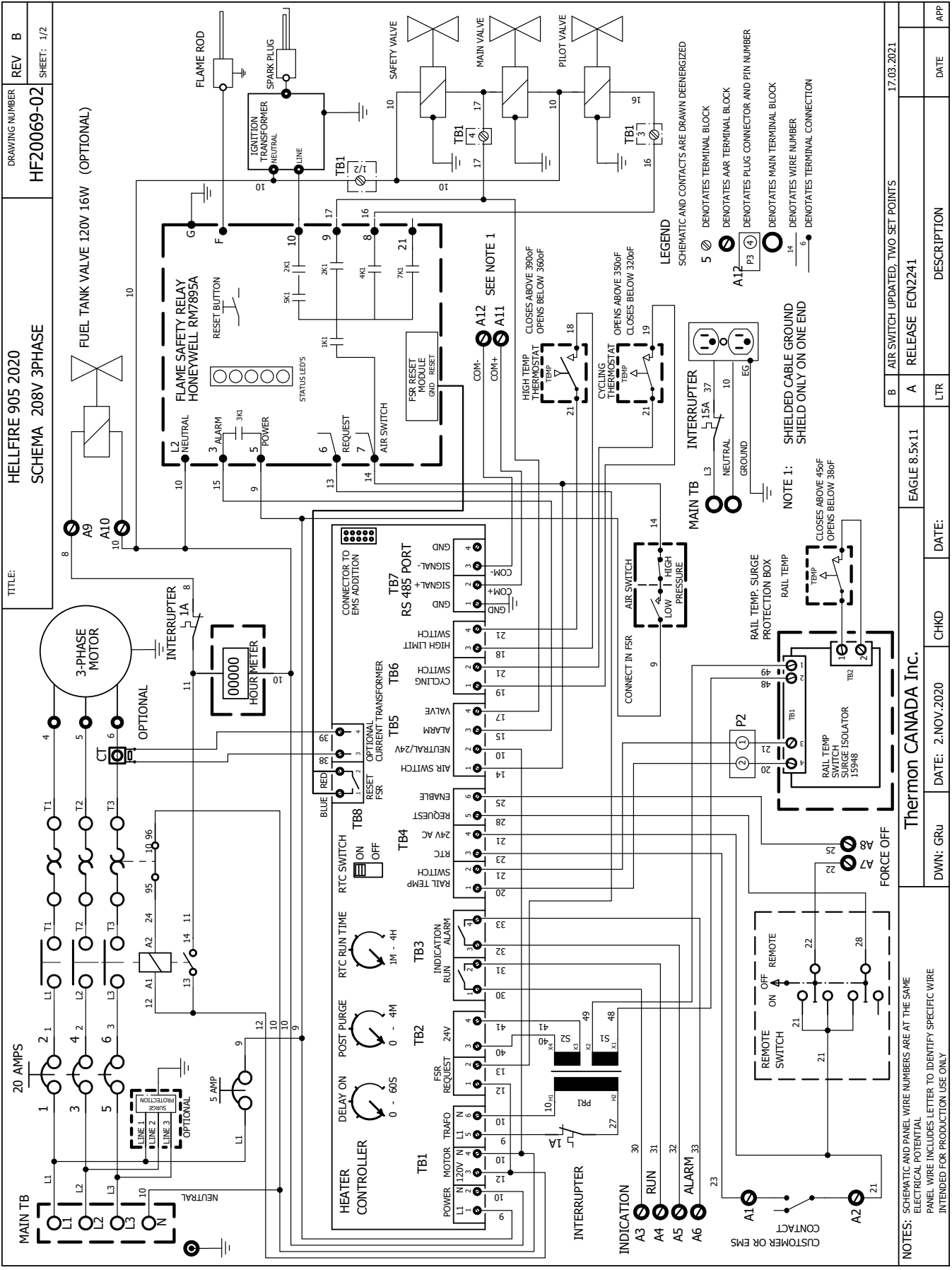

TITLE: HELLFIRE 905 2020  
 SCHEMA 208V 3PHASE

DRAWING NUMBER: HF20069-02  
 REV B  
 SHEET: 1/2

APP	DATE	DESCRIPTION	LTR	DATE	CHKD	DATE	DESCRIPTION
	17.03.2021	AIR SWITCH UPDATED, TWO SET POINTS	B				
		RELEASE ECN241	A	8.5x11	GRU	2.NOV.2020	

NOTES: SCHEMATIC AND PANEL WIRE NUMBERS ARE AT THE SAME ELECTRICAL POTENTIAL  
 PANEL WIRE INCLUDES LETTER TO IDENTIFY SPECIFIC WIRE INTENDED FOR PRODUCTION USE ONLY

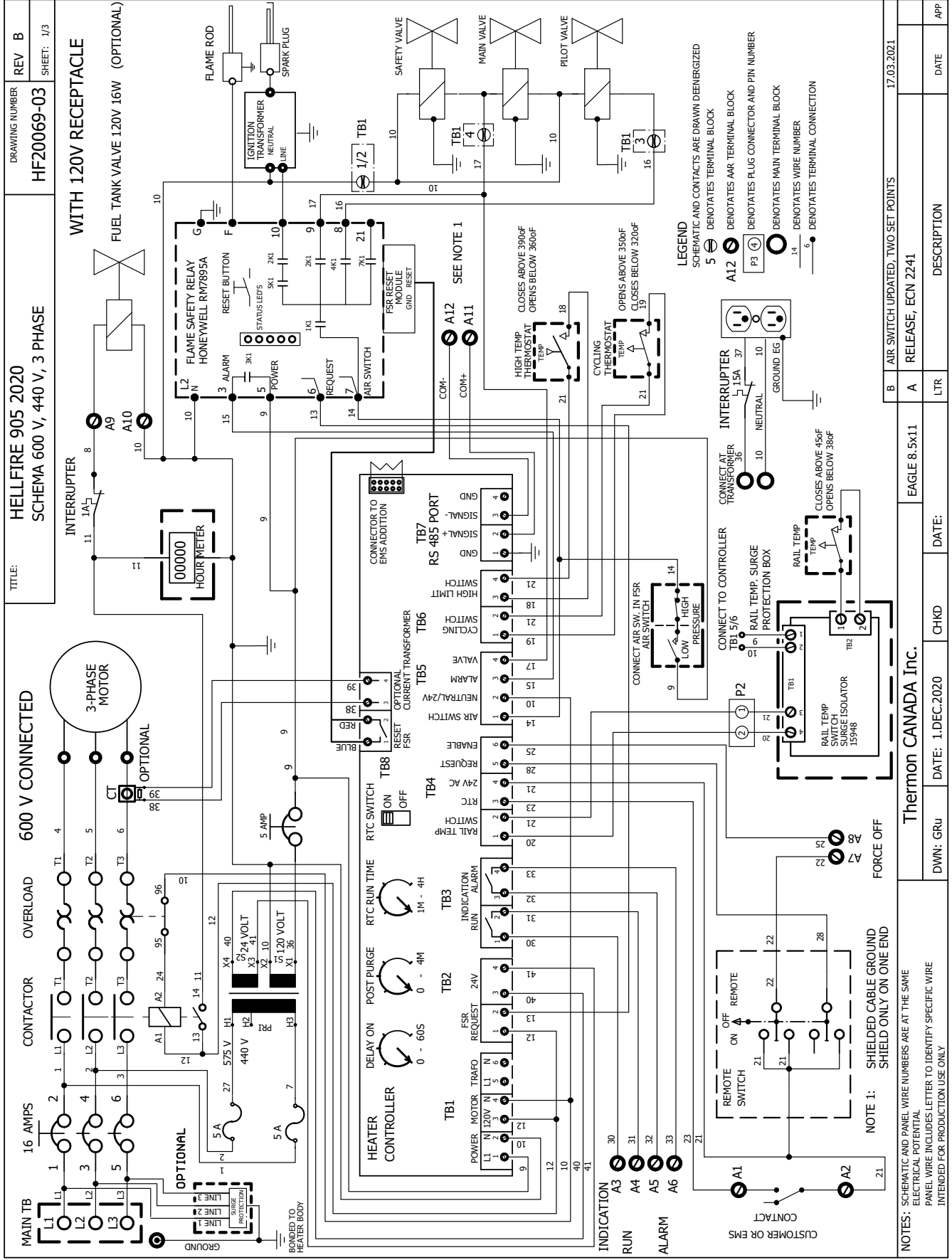

TITLE: HELLFIRE 905 2020  
 SCHEMA 600 V, 440 V, 3 PHASE

DRAWING NUMBER: HF20069-03  
 REV B  
 SHEET: 1/3

WITH 120V RECEPTACLE  
 FUEL TANK VALVE 120V 16W (OPTIONAL)

LEGEND  
 SCHEMATIC AND CONTACTS ARE DRAWN DEENERGIZED  
 5 DENOTES TERMINAL BLOCK  
 A12 DENOTES AAR TERMINAL BLOCK  
 P3 DENOTES PLUG CONNECTOR AND PIN NUMBER  
 14 DENOTES MAIN TERMINAL BLOCK  
 6 DENOTES WIRE NUMBER

NOTE 1: SHIELDED CABLE GROUND  
 SHIELD ONLY ON ONE END

NOTES: SCHEMATIC AND PANEL WIRE NUMBERS ARE AT THE SAME  
 ELECTRICAL POTENTIAL  
 PANEL WIRE INCLUDES LETTER TO IDENTIFY SPECIFIC WIRE  
 INTENDED FOR PRODUCTION USE ONLY

B	AIR SWITCH UPDATED, TWO SET POINTS	17.03.2021
A	RELEASE, ECN 2241	

DWN: GRU	DATE: 1.DEC.2020	CHKD	DATE:
EAGLE 8.5x11			
LTR			

Thermon CANADA Inc.	
DESCRIPTION	
DATE	
APP	

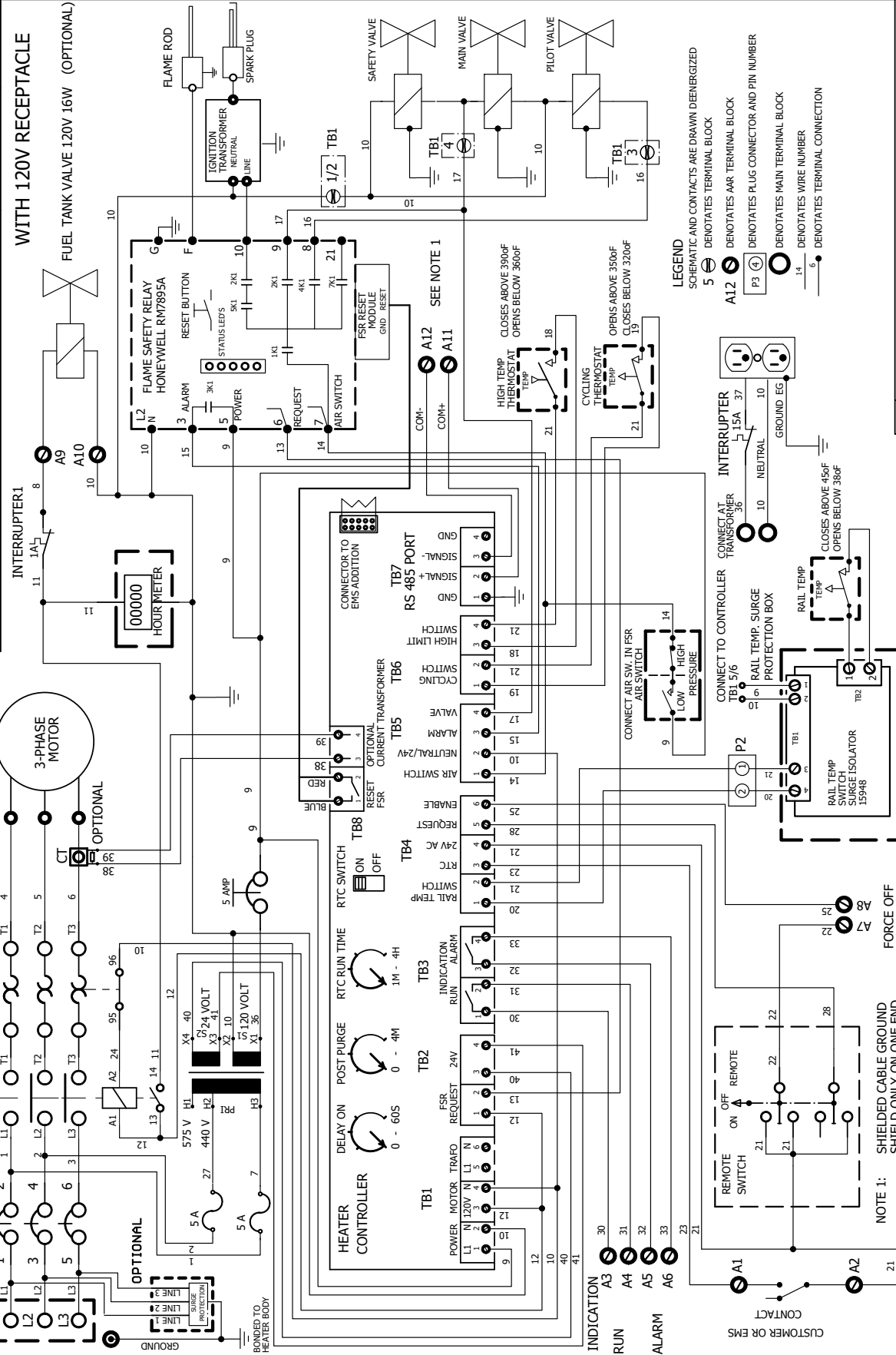

TITLE: HELLFIRE 905 2020 SCHEMA 600 V, 440 V, 3 PHASE		DRAWING NUMBER: HF20069-03		REV B	
440 V CONNECTED		WITH 120V RECEPTACLE		FUEL TANK VALVE 120V 16W (OPTIONAL)	
3-PHASE MOTOR		HOUR METER		SAFETY VALVE	
HEATER CONTROLLER		HIGH TEMP THERMOSTAT		CYCLING THERMOSTAT	
INDICATION		INTERRUPTER		RAIL TEMP SURGE PROTECTION BOX	
RUN		CONNECT TO CONTROLLER		RAIL TEMP SURGE SWITCH	
ALARM		CONNECT TO TRANSFORMER		RAIL TEMP SURGE SWITCH ISOLATOR	
CUSTOMER OR EMS CONTACT		CONNECT TO TRANSFORMER		RAIL TEMP SURGE SWITCH	
NOTE 1: SHIELDED CABLE GROUND SHIELD ONLY ON ONE END		CONNECT TO TRANSFORMER		RAIL TEMP SURGE SWITCH	
NOTES: SCHEMATIC AND PANEL WIRE NUMBERS ARE AT THE SAME ELECTRICAL POTENTIAL PANEL WIRE INCLUDES LETTER TO IDENTIFY SPECIFIC WIRE INTENDED FOR PRODUCTION USE ONLY		EAGLE 8.5x11		DATE: 17.03.2021	
Thermon CANADA Inc.		DATE: 1.DEC.2020		DESCRIPTION	
DWN: GRU		CHKD		LTR	
APP		DATE		APP	

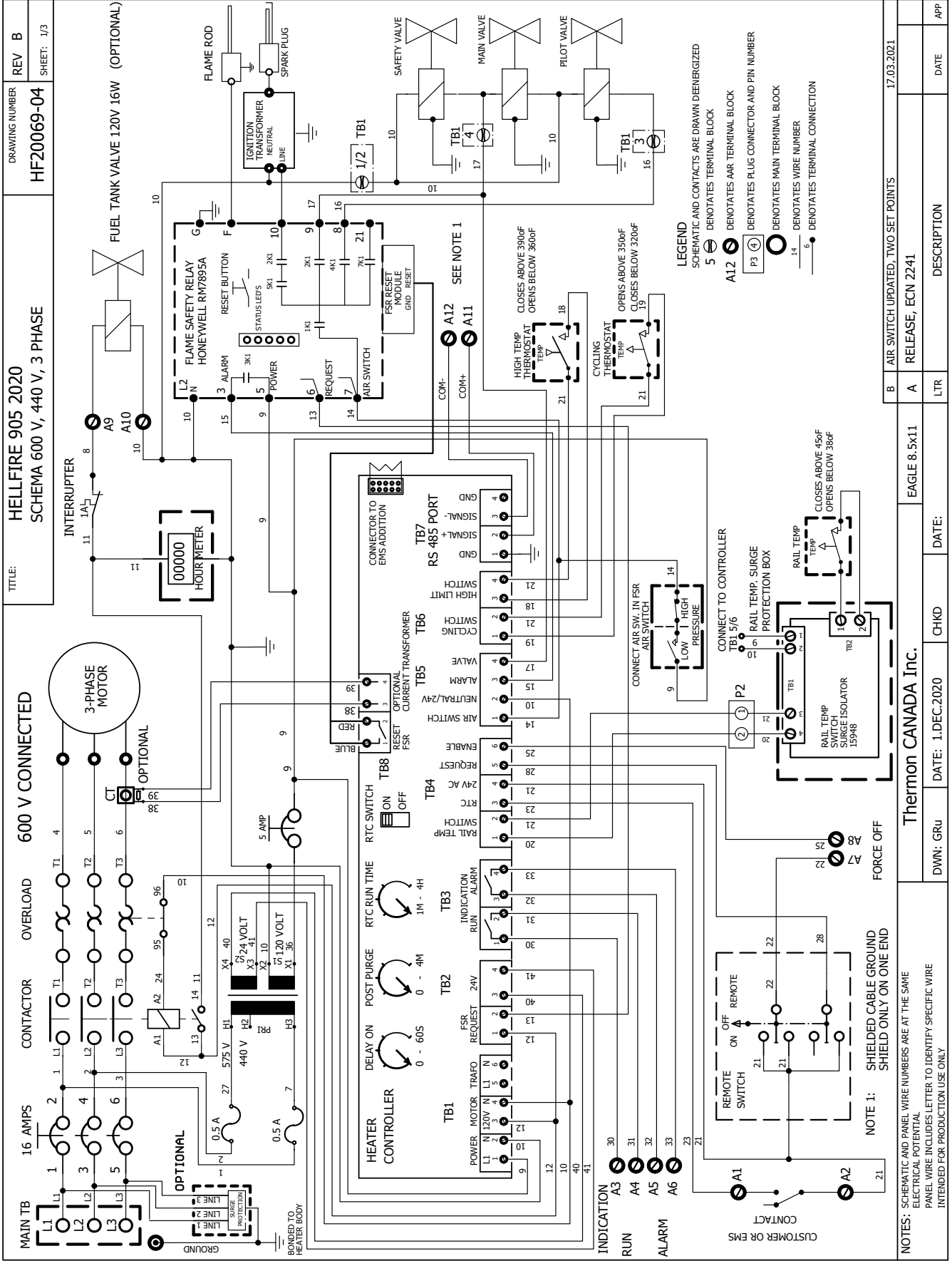

HELLFIRE 905 2020  
 SCHEMA 600 V, 440 V, 3 PHASE

DRAWING NUMBER: HF20069-04  
 REV B  
 SHEET: 2/3

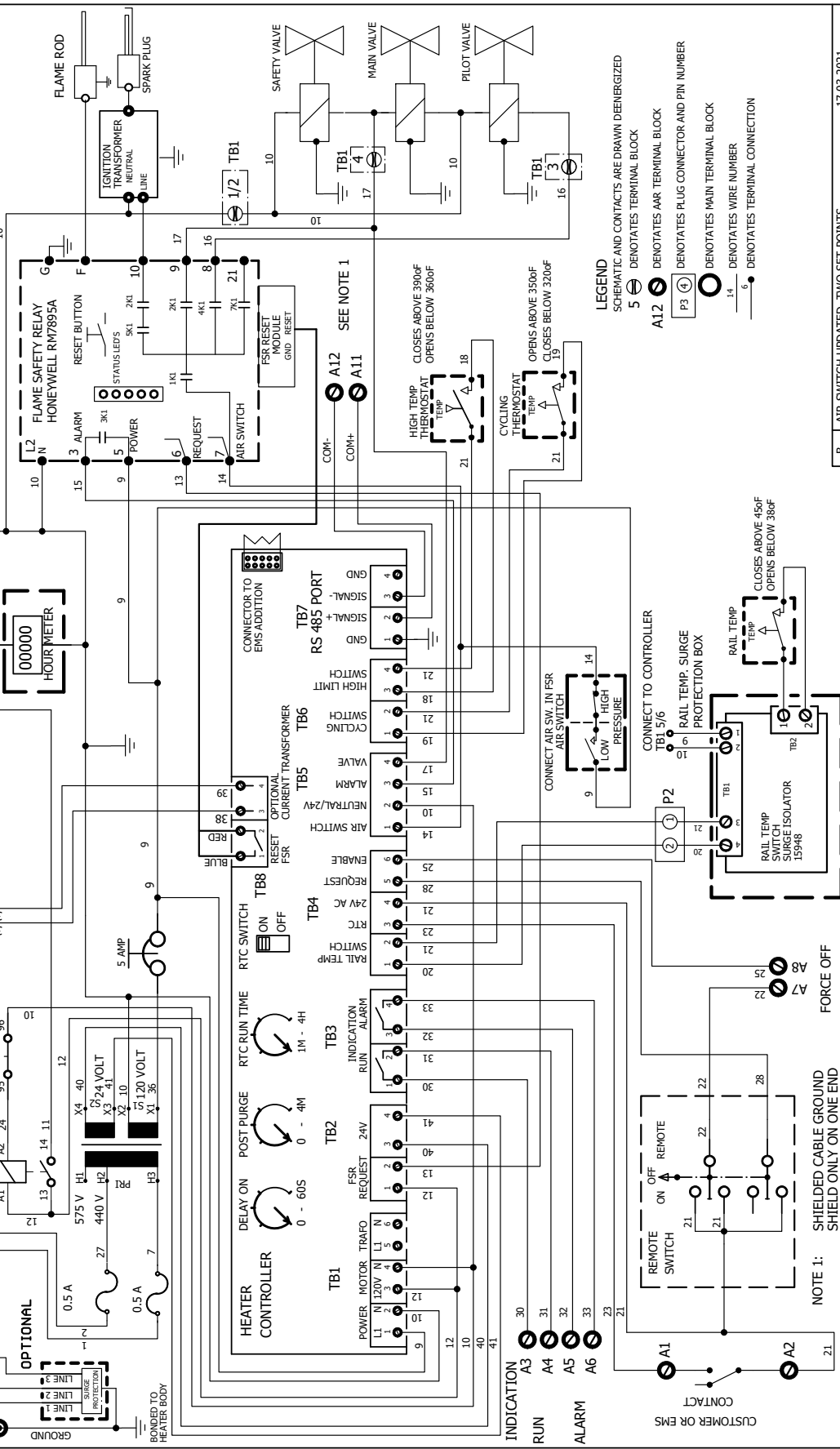

440 V CONNECTED

16 AMPS CONTACTOR OVERLOAD

3-PHASE MOTOR

OPTIONAL HOUR METER

OPTIONAL FUEL TANK VALVE 120V 16W (OPTIONAL)

LEGEND  
 SCHEMATIC AND CONTACTS ARE DRAWN DEENERGIZED  
 5 DENOTES TERMINAL BLOCK  
 A12 DENOTES AAR TERMINAL BLOCK  
 P3 DENOTES PLUG CONNECTOR AND PIN NUMBER  
 14 DENOTES MAIN TERMINAL BLOCK  
 14 DENOTES WIRE NUMBER  
 5 DENOTES TERMINAL CONNECTION

NOTES: SCHEMATIC AND PANEL WIRE NUMBERS ARE AT THE SAME ELECTRICAL POTENTIAL  
 PANEL WIRE INCLUDES LETTER TO IDENTIFY SPECIFIC WIRE INTENDED FOR PRODUCTION USE ONLY

Thermon CANADA Inc.	DATE: 1.DEC.2020	CHKD	DATE:	EAGLE 8.5x11	DESCRIPTION	DATE	APP
DWN: GRU				LTR			

# I. MAINTENANCE

## I.1 Thermostat Removal

1. Remove cover from thermostat box to gain access to the thermostats. There are two thermostats. The high limit, which has a red and a white wire connected to it, and the cycling thermostat, which has a black and a blue wire, connected to it.

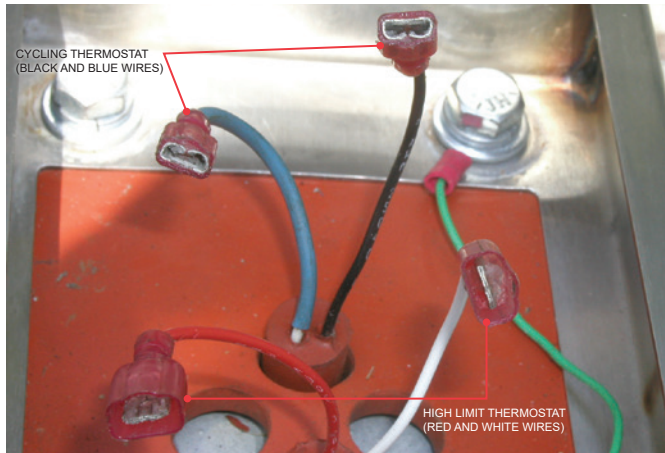

Figure 5 – Thermostat Wire Connections

2. The wires are connected by means of quick disconnects. To disconnect, grip the terminals on each side of the connection and pull firmly.
3. Using a 9/16" socket, remove the 4 mounting bolts that hold the enclosure to the sensor duct. Remove the thermostat box and gasket.
4. Remove the two screws that fasten each thermostat to the sensor duct. Remove thermostats.
5. The high limit and cycling thermostats are not interchangeable. Each has unique connectors to prevent interchange.
6. Reverse procedure to install.

## I.2 Motor/Impeller/Base Removal



**WARNING.** Risk of cutting fingers or hand. Disconnect fan power prior to removing combustion chamber access panel or air intake.

1. Remove the combustion chamber access panel to gain access to the motor.
2. Open the motor junction box and disconnect all wiring and conduit elbow.
3. Remove the four motor mount bolts and remove the motor/impeller assembly from the combustion chamber.
4. Install replacement motor/impeller/base assembly, following reverse order.
5. Ensure impeller cone is properly centred to intake funnel and does not contact. Impeller inlet should slightly overlap intake funnel.

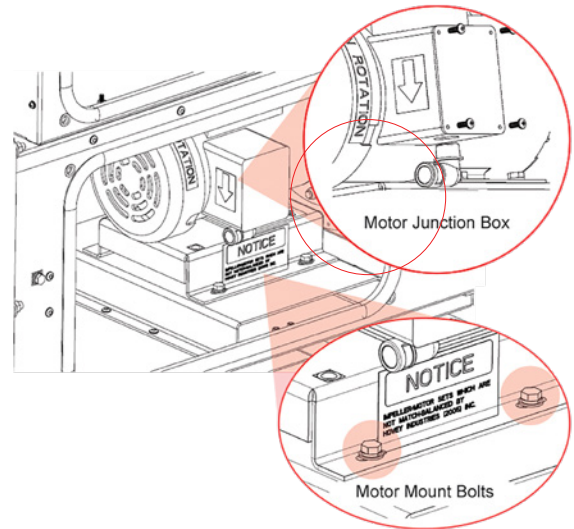

## I.3 Impeller Removal

**NOTE:** Motor/impeller sets not match balanced by Thermon void future warranty claims.

**NOTE:** Replacement of motor or impeller only. Dynamically balance the motor/impeller and base assembly to vibration levels of 0.2 in/sec or less in the bearing planes.

**NOTE:** Mark the position of the impeller on the shaft before removing.

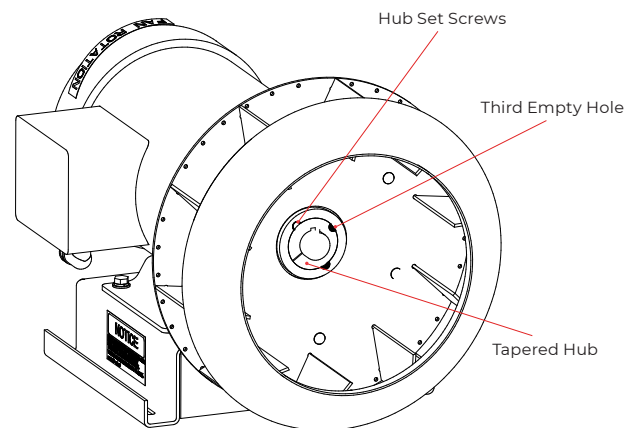

The impeller is fitted with a taper lock bushing. To remove impeller from motor shaft:

1. Clamp the motor and anchor the impeller using a suitable bar.
2. Remove the two hub set screws.
3. Insert a set screw into the third previously empty hole and tighten.
4. Tap the outer half of the hub with a hammer and bar to knock the impeller off the tapered hub.
5. Slide hub off shaft, then remove impeller.
6. To install the impeller, reverse sequence except step 4.

#### I.4 Flame Rod and Spark Igniter Removal

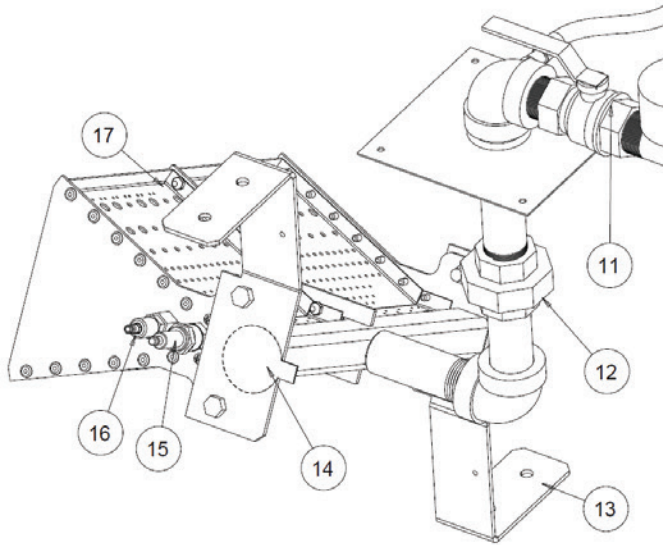

If the flame rod (16) or spark igniter (15) requires inspection or replacement, remove them as follows:

1. Gain access to the burner (17) by first removing the combustion chamber access panel.
2. The flame rod is to the left of the spark igniter. Gently pull the wire from the terminal. Use a 7/8" deep socket to unscrew and remove the flame rod. Apply a high temperature anti-seize compound to threads prior to reinstallation.
3. The spark igniter is to the right of the flame rod. Gently pull the wire from the terminal. Using a 13/16" deep socket, unscrew and remove the spark igniter. Apply a high temperature anti-seize compound to threads prior to reinstallation.
4. Reinstall the flame rod and ignition wires. A red band identifies the flame rod wire.

#### I.5 Burner Removal

1. Turn heater OFF and disconnect power.
2. Once impeller is at a complete stand still, remove combustion chamber access panel.
3. Remove spring wedge holding defroster (14). Remove cable strap from mounting bracket. Pull defroster out and let it hang.
4. Open pipe union (12).
5. Remove bolts fastening both mounting brackets (13) to the combustion chamber. Leave brackets attached to the burner.
6. Remove burner.
7. Reverse procedure to reinstall.

#### I.6 Burner Defroster Removal

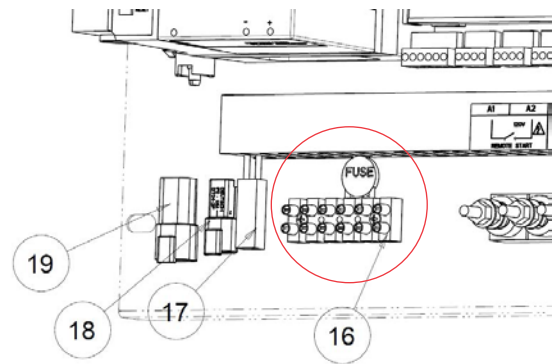

**NOTE:** The defroster circuit is protected with a reset-enabled fuse. If tripped, open then close the panel breaker to reset.

1. Turn heater OFF and disconnect power.
2. Once impeller is at a complete stand still, remove combustion chamber access panel.
3. Remove spring wedge holding defroster (14). Remove cable strap from mounting bracket.
4. Pull defroster out and let it hang.
5. Open electrical access panel. Trace defroster wires to terminal block (16), terminals 5 and 6, circled. Disconnect last two wires on the bottom furthest right of terminal block.
6. Reverse procedure to reinstall.

## J. SERVICE



**WARNING.** Install and use Heater in accordance with owners manual and local codes.

In the absence of local codes, installation must comply with CAN/CSA-B149 Installation code and National Fuel Gas Code ANSI Z223.1 / NFPA 54, or Standard for the Storage and Handling of Liquefied Petroleum Gases, ANSI / NFPA 58.

For outdoor use only.

For use with ductwork only. Only duct work supplied by Thermon Heating Systems shall be used with the heater. Minimum clearance from combustibles: 2 in.



**WARNING.** To be installed in accordance with railroad and all applicable local governing regulations by persons approved by the railroad having authority.



**WARNING.** If you smell gas; immediately extinguish all sources of ignition and turn off gas source. Call qualified service technician to repair leak.



**WARNING.** Do not attempt to manually light burner. Heater equipped with an automatic electronic ignition system.



**WARNING.** Risk of cutting fingers or hand. Disconnect fan power prior to removing combustion chamber access panel or air intake.



**WARNING.** Heater can start automatically. Exercise caution when in close proximity.



**WARNING.** Burn hazard / hot surfaces. Do not touch track ducts, nozzles or any non-insulated duct connected downstream of heater during operation



**WARNING.** Cut hazard. Sheet metal edges can be sharp. Wear protective clothing when handling track duct, insulated ducts and any other sheet metal components.

### J.1 Recommended Service Schedule

Item	Annually	Every 5 Years
Inspect flame rod	X	
Inspect flame rod wire and boot	X	
Inspect igniter	X	
Inspect igniter wire and boot	X	
Inspect ductwork	X	
Measure motor vibration	X	
Inspect and tighten all electrical terminations	X	
Inspect and replace any damaged access panel gaskets	X	
Inspect and replace any damaged duct gaskets	X	
Inspect gas supply pressure	X	
Perform gas supply leak test	X	
Perform manifold leak test	X	
Inspect burner	X	
Service burner		X

1. Inspect heater annually.
2. Ensure the air intake and all ductwork are not obstructed.
3. Keep area around heater clear and free from combustible material, gasoline and other flammable vapours and liquids.
4. Replace all damaged ducts, including intake, crossducts, point and track duct nozzles.
5. Damaged ducts will degrade switch clearing ability.
6. With the supply power turned off, tighten all mounting and electrical connections to the recommended tightening torque.

Thread Size	Tightening Torque (in./lbs)
8 - 32	19
10 - 32	31
1/4 - 20, Power Terminal Lugs and AAR Terminals	75



## J.2 Gas Supply Pressure



**WARNING.** All persons employed in handling propane or natural gas shall be trained in proper handling and operating procedures, as required by local authorities having jurisdiction.

1. Heater is factory tested on propane at 10 psi supply pressure.
2. With the heater on and all connected loads operating, verify that the supply pressure, indicated on supply pressure gage (7), is between 5 - 20 psi.
3. Natural gas pressures below 5 psi or LPG pressures below 2 psi will limit the maximum capacity of the heater.

## J.3 Gas Supply Leak Test

1. With the heater "OFF", paint all the gas pipe connections between the supply inlet (6) to the gas source with leak testing solution. If a gas leak is detected, replace any cracked fittings or components, tighten any leaking pipe connection, or disassemble, reapply pipe thread sealant, and reassemble.

## J.4 Manifold Leak Test

1. With the heater "OFF", paint all the gas pipe connections between the main (8), pilot (3) gas solenoid valves and the supply inlet (6) with leak testing solution.
2. With the heater operating in "MANUAL" mode and the burner lit, paint all pipe connections between the main and pilot gas solenoid valves to the elbow with leak test solution.
3. If a gas leak is detected, turn heater "OFF". Replace any cracked fittings or components, tighten any leaking pipe connection, or disassemble, reapply pipe thread sealant, and reassemble.

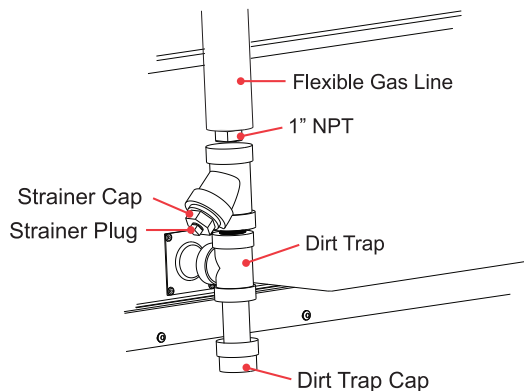

## J.5 Main And Safety Gas Solenoid Valves Leak Test

1. Turn heater OFF.
2. Verify supply pressure is between 5 – 20 psi.

3. Close the manual pilot gas shut off valve (5) upstream of the pilot gas regulator (4), with the handle perpendicular with the pipe.
4. With the manifold pressure gage (10) reading "0", close the manual gas shut off valve(11), downstream of the main and safety gas solenoid valve (9).
5. After 10 minutes there should be no increase of pressure on the downstream gauge. If there is an increase, refer to the Honeywell gas valve manual in the component bulletin section at the end of this manual, for service information.

## J.6 Dirt Trap And Strainer



**WARNING.** All persons employed in handling propane or natural gas shall be trained in proper handling and operating procedures, as required by local authorities having jurisdiction.

1. If a dirty supply line is suspected, turn off the local gas supply, remove the dirt trap cap and inspect for dirt and moisture.
2. If a strainer is installed, remove center plug and inspect for blockage. If evidence is found, locate source and correct problem.
3. If the strainer screen is clogged, remove the cap and screen. Old gasket is not reusable. Clean screen. Apply sealant to plug threads. Reinstall cleaned screen, cap with new gasket, and plug.
4. Inspect manifold and clean if necessary.
5. Empty cap of any dirt or moisture. Apply thread sealant and reinstall cap.
6. Turn on gas supply and leak test dirt trap.
7. Perform Main And Safety Gas Solenoid Valves Leak to ensure valve seats seal.

## J.7 Motor

Running amps greater than 115% of the motor rated full load amps can indicate failed bearings, excessive air leaks in the ductwork, inadequately sized power supply wires, or poor electrical connections.

Voltage	Phase	Motor FLA Rating*	FLA X 1.15**
240	1	21	24.2
208	3	13.2	15.2
460	3	5.7	6.6
575	3	4.6	5.3

\* FLA (Full Load Amperage), as shown on motor nameplate.

\*\* Maximum current draw under design operating conditions of -40°C/°F ambient temperature at sea level and supply voltage. Current draw drops with temperature, elevation or voltage increase.

**NOTE:** Measure current between motor and contactor or soft start (if equipped), not at the supply terminals.

## J.8 Vibration Specifications and Measurement

1. All motor/impeller/base sets are match balanced with vibration levels lower than 0.20 in./sec RMS, at the four points depicted.

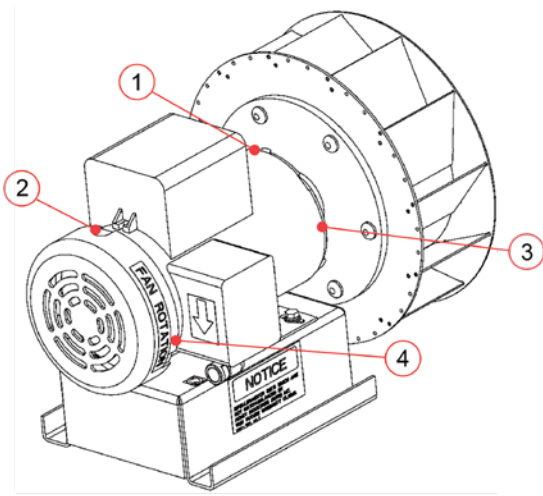

2. Do not measure on covers or guards.
3. Mark locations 1, 2, 3 and 4 on motor to ensure repeatable measurements for trend analysis.
4. Take measurements vertically at points 1 and 2, and horizontally at 3 and 4.

Vibration Level (in./sec)	
Acceptable	Less than 0.20
Tolerable	0.21 to 0.29
Excessive	0.30 to 0.71
Extreme	0.72 or more

## J.9 Lubrication

1. The motor has sealed bearings and does not require lubrication.
2. When installing flame rod or igniter always apply high temperature anti seize compound to threads.

## J.10 Flame Safety Relay (FSR)

1. Ensure that adequate gas pressure is available.
2. Note the 5 LEDs on the front face of the FSR.
3. The following is the normal expected status LED sequence:
  - 3.1 With adequate power, the green POWER will be lit and will blink every 4 seconds, indicating standby mode.
  - 3.2 Turn the mode selector switch to "MANUAL". The blower will start, followed by the trial for ignition. The yellow PILOT LED will light.
  - 3.3 Once the burner is lit and a flame signal is established, the red FLAME LED lights.
  - 3.4 After 10 seconds, the yellow MAIN LED lights, leaving four lit LEDs, the POWER, FLAME, PILOT and MAIN.

- 3.5 The LEDs maintain this status until the cycling thermostat reaches its set point and turns off the request for heat.
4. As a further check, close the manual gas valve. The FLAME LED goes out, followed by the MAIN and PILOT LED, the red ALARM LED lights. Open manual gas valves. Reset controller, which in turn resets FSR.
5. For further information see the Honeywell 7800 series RM7895A Relay manual in the component bulletins section at the end of this manual.

## J.11 Flame Signal

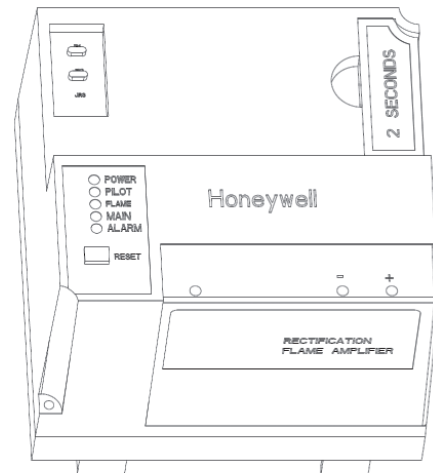

**NOTE:** Flame signal strengths:

- GOOD - 2.5V or greater, fluctuating less than 0.5V
- WEAK – between 1.2V and 2.5V and / or fluctuating more than 0.5V
- INSUFFICIENT – below 1.2V

1. The flame signal strength can be monitored using a voltmeter set to measure 0 - 10V DC, or using the plug in Honeywell display module.
2. When using a voltmeter, insert the red lead into the positive (+) jack and the black into the negative of the flame signal amplifier located on beneath the FSR.
3. Voltage is 0.0 with no flame, and a maximum of 5V with flame.
4. Signals between 1.2V to 2.5V and / or fluctuating more than 0.5V are weak. They allow the heater to continue to operate, however investigation and probable maintenance of flame rod, wiring, manifold pressure and burner is required. Expect irregular nuisance shutdowns.
5. Flame signals dropping below 1.2V cause the FSR to extinguish the burner and indicate alarm.
6. Inspection and probable maintenance of flame rod, wiring, pressure and burner is required.

### J.12 Air Switch

1. To check the air switch operation, while operating the unit, block 80% of the air intake screens openings with a sheet of cardboard. The heater continues to operate.
2. Now block 90%. The FSR extinguishes the burner and indicates alarm.
3. Remove the blockage and reset the controller. The heater starts.

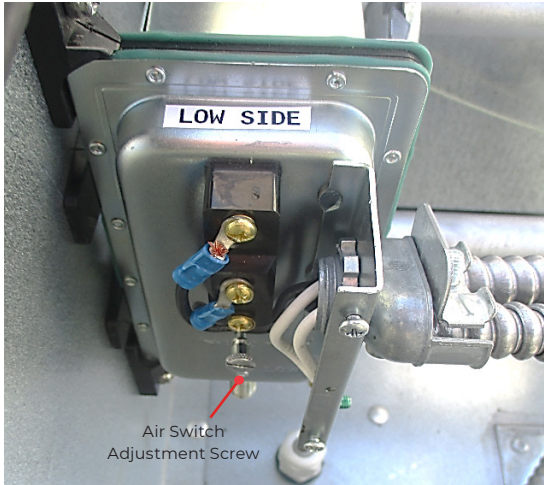

### J.13 Air Switch Calibration



**WARNING.** Warning Risk of Electric Shock

1. With the heater operating, remove the low pressure side terminal cover to expose the air switch set screw. Turn the set screw counter clockwise to lower the set point. Block 90% of the air intake with cardboard.
2. Raise the set point by turning the screw clockwise until the switch opens and causes the FSR to safety shutdown.
3. Remove blockage and reset FSR.

### J.14 High Temperature Limit

1. Turn the mode selector switch "OFF".
2. Open the thermostat box located on the sensor duct. Disconnect the blue and black leads of the cycling thermostat.

3. Use a jumper and short them together.
4. Turn the heater on, "MANUAL", and let it run.
5. Increase the manifold pressure to the maximum rated setting. Once the air temperature exceeds the 216°C (420°F) set point, the controller removes the request for heating, HEAT LED off, indicates alarm with STATUS LED red, FSR ALARM LED red, ALARM LED red and HIGH LIM LED alternating. The fan continues to run for 4 minutes of post purge.
6. Return the mode selector switch to desired mode.
7. Reconnect the cycling thermostat and reset the controller.

### AAR Terminals, Signals, and Communications

### J.15 AAR Terminals, Signals, and Communications

1. To verify remote start:
  - 1.1 Place the heater in REMOTE RTC mode, and make a contact closure across AAR terminals A1 A2. The heater starts after the delay on period.
2. To verify RUN indication:
  - 2.1 Measure continuity across AAR terminals A3 A4. If equipped with powered run option, measure voltage instead of continuity.
  - 2.2 If equipped with powered run option, presence of 24V DC indicates run, 0V indicates stopped.
3. To verify ALARM indication:
  - 3.1 Measure continuity across AAR terminals A5 A6.
  - 3.2 Closed contact indicates alarm, open indicates normal operation. Confirm against actual heater state.
4. To verify FORCE OFF:
  - 4.1 Place the heater in MANUAL mode, open contact closure across AAR terminals A7 A8.
  - 4.2 The heater will stop after the post purge period.
5. To verify the tank valve switch:
  - 5.1 Measure the voltage across terminals A9 A10. With fan running the voltage is 120V AC.
6. To verify RS-485 communications:
  - 6.1 Refer to controller LED indications for TD, RD, and TX.

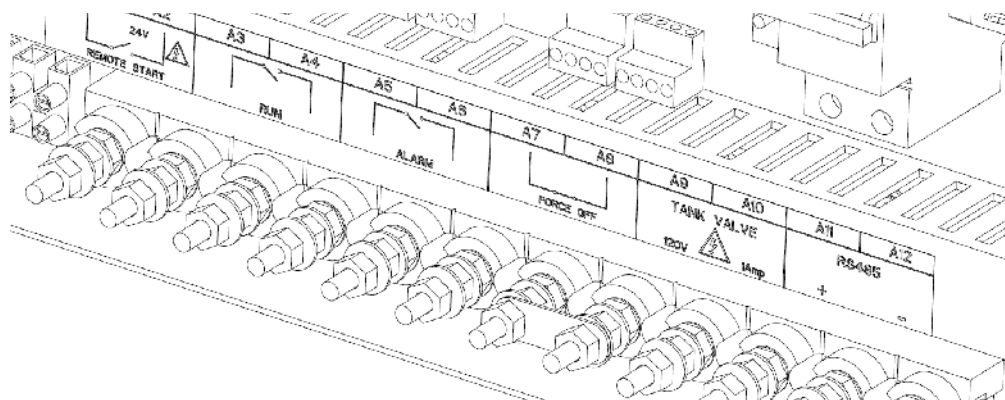

### J.16 Burner

1. Visually inspect mixing plates for cracks or blockage. Remove any blockages. If cracks are found replace the burner.
2. Over time corrosion and or dirt restrict the burner orifice.
3. Inspect burner for blocked gas orifice, if:
  - 3.1 Signal strength is low even after replacing the flame rod and wire,
  - 3.2 Pilot pressure has to be raised significantly to get a good signal,
  - 3.3 Manifold pressure is above the maximum gas pressure setting to achieve a 121°C (250°F) increase of output air temperature.
4. To correct the problem, remove the burner, flame rod and igniter, following the removal instructions in the maintenance section.
5. Drill out any blocked gas orifice using a #47 (.0785) drill bit.

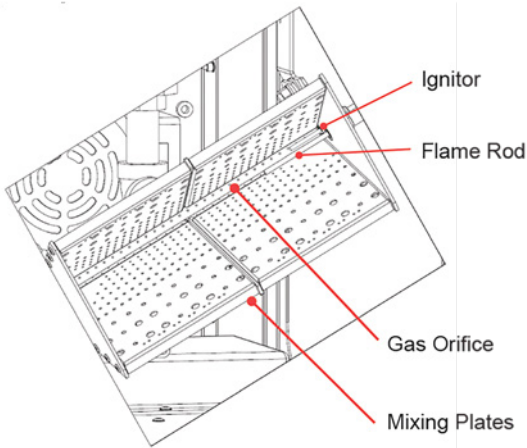

### J.17 Defroster

1. The defroster applies 30 watts of heat to the burner next to the flame rod and igniter. This is enough to raise the temperature of the end plate by approximately 90°F. It can be difficult to tell it is heating by sense of touch, therefore measure the current draw using a clip on ammeter. The current draw is 1.25 amps. A resettable fuse mounted on the terminal block protects this circuit.

If there is no current draw, open the 5-amp panel breaker, then close it to reset the fuse. If there is still no current draw, inspect defroster for damage.Parts

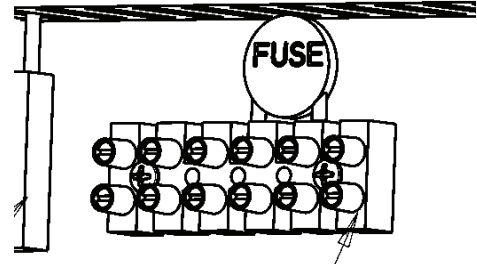

# K. PARTS

## K.1 Parts - Heater Body

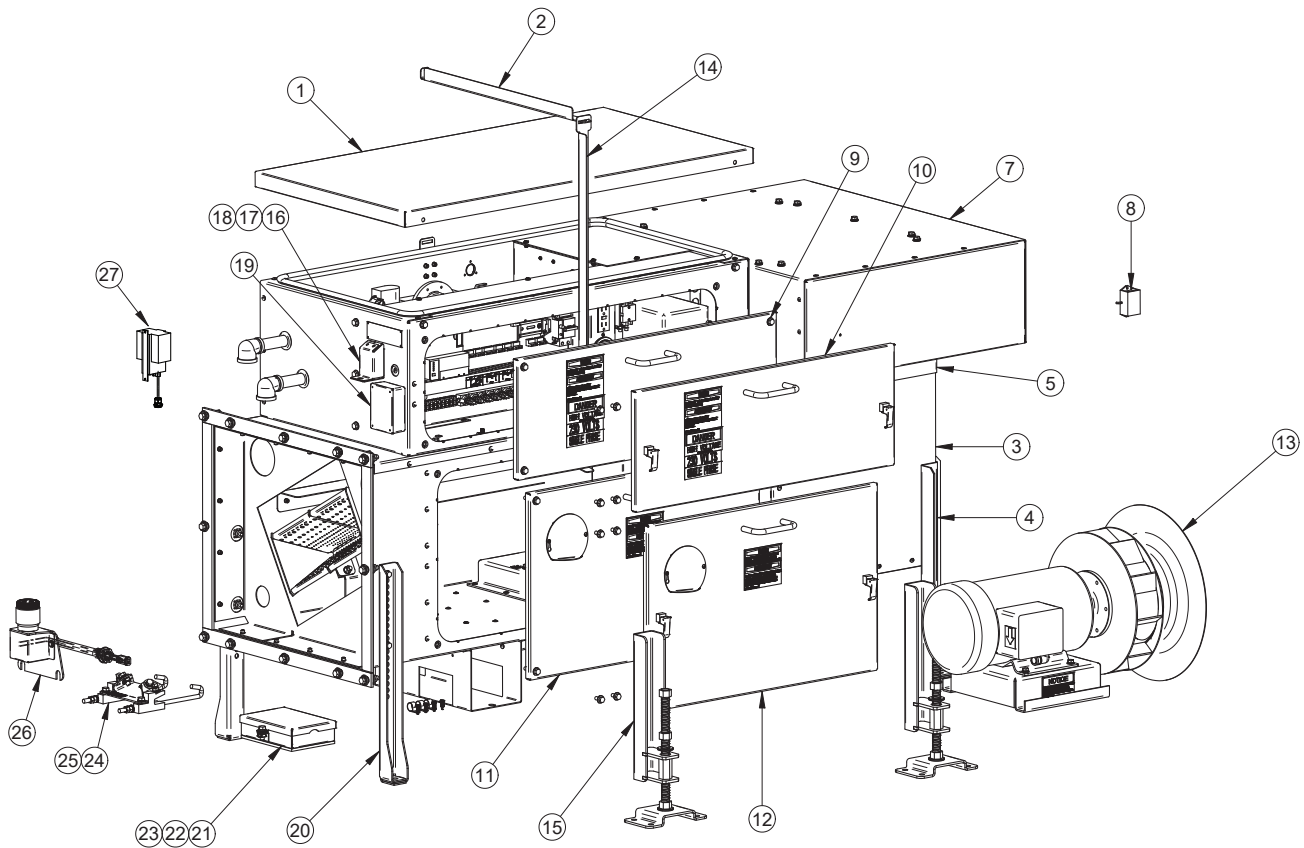

Table 20 – Heater Body Parts List

Index	Part No.	Description
1	HF18929	TOP LID, CONTROLS
2	HF17437-01	LOCKING BAR, TOP
3	HF20047	PLENUM, INTAKE, HF905
4	HF16075	LEG, REAR, HF400/900
5	HF20044	EXT, INTAKE W/SCREEN, 13"L HF905
6	HF20045	EXT, INTAKE W/SCREEN, 43"H HF905
7	HF20046	HOOD, AIR INTAKE, HF905
8	HF16426	TEMP SNSR ASSY, AMB
9	HF20050-XX	PANEL, ACCESS, ELEC. CHMBR, ASSY., BOLT ON, HF905
	-01	240V with Soft Starter
	-02	240V Single Phase
	-03	208V 3 Phase
	-04	460V 3 Phase
	-05	575V 3 Phase
-06	575V 3 Phase with Duplex	
10	HF20051-XX	PANEL, ACCESS, ELEC. CHMBR, ASSY., QIK. RLSE. HF905
	-01	240V with Soft Starter
	-02	240V Single Phase
	-03	208V 3 Phase
	-04	460V 3 Phase
	-05	575V 3 Phase
-06	575V 3 Phase with Duplex	
11	HF18939	PANEL, ACCESS, COMB CHMBR, ASSY., BOLT ON

Index	Part No.	Description
12	HF18938	PANEL, ACCESS, COMB CHMBR, ASSY., QIK. RLSE.
13	HF20038-XX	MOT/IMPLR ASSY, HF905
or	-01	HF905 208/230/460V AC 3 Phase
or	-02	HF905 240V AC Single Phase
or	-03	HF905 575V AC 3 Phase
14	HF17437-02	LOCKING BAR, FRONT
15	HF16685	LVL LEG ASSY, HF900/400, SCREW
16	HF17344	BOX, TOGGLE SW LOCK OUT
17	HF9038-0057	SW TOGGLE, SPDT ON-OFF-ON
18	HF9038-0060	SW BOOT, BLACK NEOPRENE
19	HF15948	SURGE ISOLATOR, RAIL THERMO W/ CMPNTS
20	HF16076	LEG, FRONT, HF400/900, BOLT ON
21	HF13032	BOX, TEMP PROBE
22	HF13340-01	THERMO ASSY, TEMP CNTRL, HI LIMIT
23	HF13340-02	THERMO ASSY, TEMP CNTRL, CYCLING
24	HF17895	ENCL, SNAP SW, RAIL W/ MTG
25	HF13340-04	THERMOSTAT ASSY, RAIL, COR
26	13849-01	PPT SNSR, C/W 6' CABLE ASSY
or	13849-03	PPT SNSR HEAD
27	HF16708-04	SW AIR, HF905, CALIBRATED

Note: This list identifies the major components only. Recommended spare parts highlighted red.

Note: 43" Intake not shown for clarity.

## K.2 Parts - Control Panel, 240V Single Phase

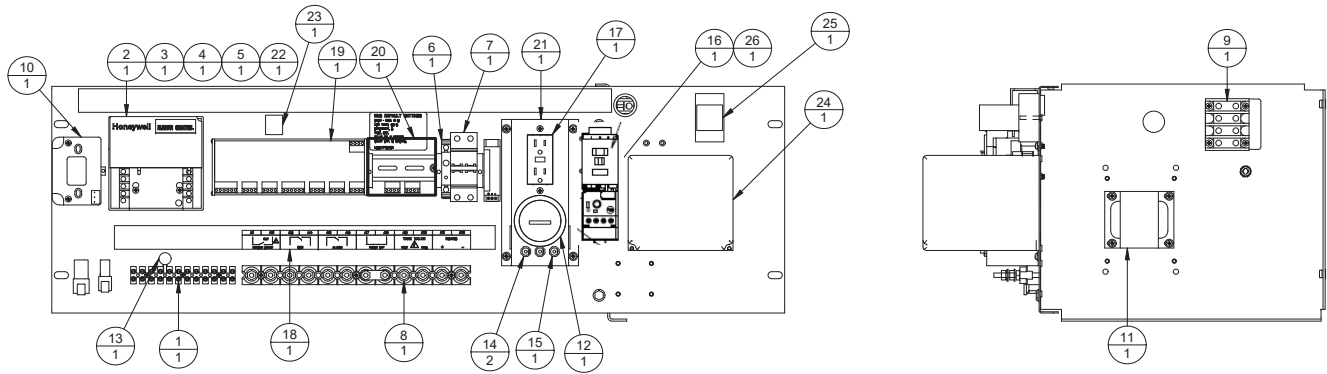

Table 21 – Control Panel Parts List

Index	Part No.	Description
1	9012-0059	TERMINAL BLOCK, 12 POLE
2	9040-0018	RELAY, FS, BURNER CONTROL
3	9040-0022	AMPLIFIER, FS, MDL
4	9040-0023	CARD, FS, PURGE TIMER, 2 SEC
5	9040-0042	BASE, RELAY, FS, RM7800 PANEL MTG
6	9042-0044	CB, 1 POLE 5 A
7	9042-0072	CB, 2 POLE 40 A
8	9043-0004	BLOCK, TERM AAR 12 POLE C/W HDW
9	9043-0025	BLOCK, TERM 4 POLE, 600V 115A
10	9064-0021	TRFRMR, IGN, 120V PRI
11	9064-0030	TRFRMR, CONT 120>24V & 120V 100 VA
12	9069-0015	METER, ELAPSED TIME HRS, 120V AC 60HZ
13	9077-0033	FUSE, RESETTABLE
14	9077-0034	CB, 1A, PNL MNT

Index	Part No.	Description
15	9077-0035	CB, 15A, PNL MNT
16	9078-0130	PROTECTIVE COVER, CONTACTOR, 2 POLE
17	9079-0004	RCPT, DUPLEX 15A-125V, GFCI SMARTLOCK
18	18532	LABEL, AAR CONNECTOR, VINYL
19	18783-02	CONTROLLER, 900 HEATER
20	18784	EMS MODULE
21	18931	BRKT, FUSE & HR METER
22	18934	RESET MODULE
23	19018	PROGRAMMING KEY, CONTROLLER
24	HF20042	SOFT STARTER (IF EQUIPPED)
25	HF20052	RELAY (SOFT STARTER OPTION ONLY)
26	9040-156	THERMAL OVERLOAD RELAY, 9 - 45 A

Note: This list identifies the major components only. Recommended spare parts highlighted red.

## K.3 Parts - Control Panel, 208V Three Phase

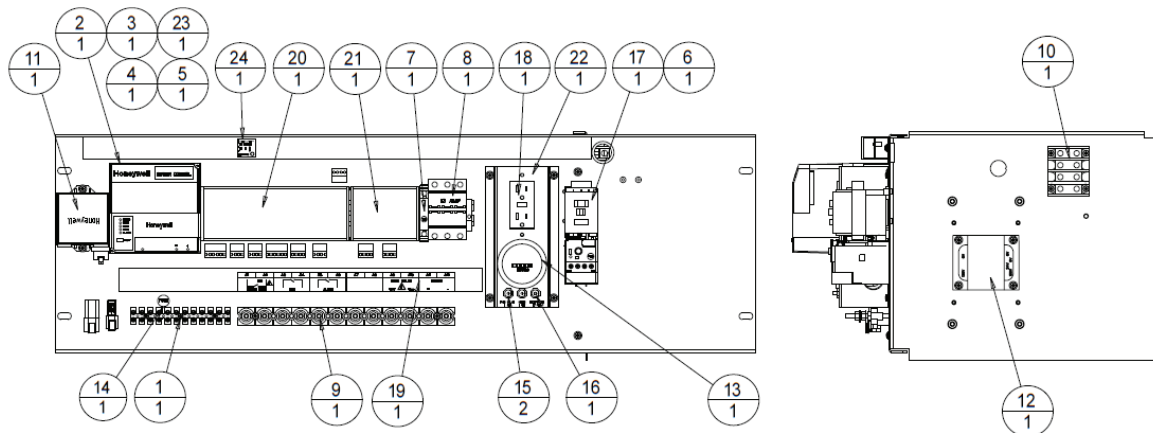

Table 22 – Control Panel Parts List

Index	Part No.	Description
1	9012-0059	TERMINAL BLOCK, 12 POLE
2	9040-0018	RELAY, FS, BURNER CONTROL
3	9040-0022	AMPLIFIER, FS, MDL
4	9040-0023	CARD, FS, PURGE TIMER, 2 SEC
5	9040-0042	BASE, RELAY, FS, RM7800 PANEL MTG
6	9040-0152	THERMAL OVERLOAD RELAY, 5.4 - 27 A, 3PHASE
7	9042-0044	CB, 1 POLE 5 A
8	9042-0073	CB, 3 POLE 20A
9	9043-0004	BLOCK, TERM AAR 12 POLE C/W HDW
10	9043-0025	BLOCK, TERM 4 POLE, 600V 115A
11	9064-0021	TRFRMR, IGN, 120V PRI
12	9064-0030	TRFRMR, CONT 120>24V & 120V 100 VA
13	9069-0015	METER, ELAPSED TIME HRS, 120V AC 60HZ

Index	Part No.	Description
14	9077-0033	FUSE, RESETTABLE
15	9077-0034	CB, 1A, PNL MNT
16	9077-0035	CB, 15A, PNL MNT
17	9078-0129	CONTACTOR, 16A C/W 120V COIL
18	9079-0004	RCPT, DUPLEX 15A-125V, GFCI SMARTLOCK
19	18532	LABEL, AAR CONNECTOR, VINYL
20	18783-02	CONTROLLER, 900 HEATER
21	18784	EMS MODULE
22	18931	BRKT, FUSE & HR METER
23	18934	RESET MODULE
24	19018	PROGRAMMING KEY, CONTROLLER

Note: This list identifies the major components only. Recommended spare parts highlighted red.

K.4 Parts - Control Panel, 460V/575V Three Phase

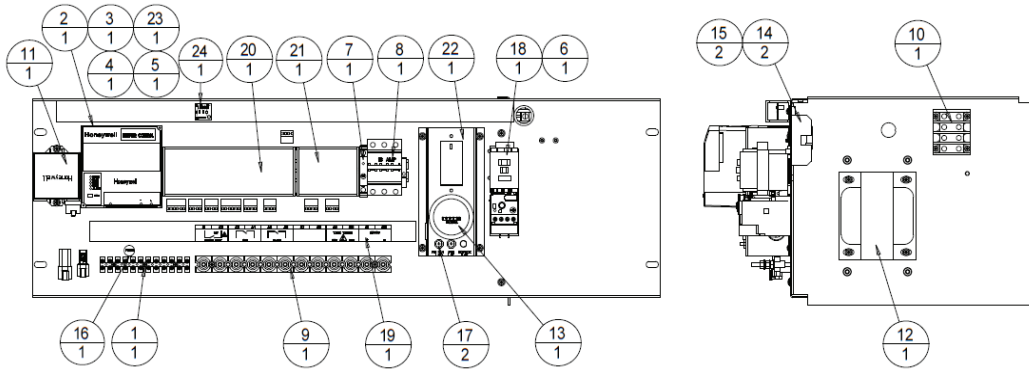

Table 23 – Control Panel Parts List

Index	Part No.	Description
1	9012-0059	TERMINAL BLOCK, 12 POLE
2	9040-0018	RELAY, FS, BURNER CONTROL
3	9040-0022	AMPLIFIER, FS, MDL
4	9040-0023	CARD, FS, PURGE TIMER, 2 SEC
5	9040-0042	BASE, RELAY, FS, RM7800 PANEL MTC
6	9040-0152	THERMAL OVERLOAD RELAY, 5.4 to 27A, 3PHASE
7	9042-0044	CB, 1 POLE 5 A
8	9042-0071	CB, 2 POLE 10-16A
9	9043-0004	BLOCK, TERM AAR 12 POLE C/W HDW
10	9043-0025	BLOCK, TERM 4 POLE, 600V 115A
11	9064-0021	TRFRMR, IGN, 120V PRI
12	9064-0031	TRFRMR, CONT 460/575>120V 4A /24V 4A (for standard configuration, no receptacle)
13	9069-0015	METER, ELAPSED TIME HRS, 120V AC 60HZ

Index	Part No.	Description
14	9077-0028	FUSE HOLDER, PANEL MOUNT
15	9077-0031	FUSE, 1.5 AMP 600V
16	9077-0033	FUSE, RESETTABLE
17	9077-0034	CB, 1A, PNL MNT
18	9078-0126	CONTACTOR, 12A C/W 120V COIL
19	18532	LABEL, AAR CONNECTOR, VINYL
20	18783-02	CONTROLLER, 900 HEATER
21	18784	EMS MODULE
22	18931	BRKT, FUSE & HR METER
23	18934	RESET MODULE
24	19018	PROGRAMMING KEY, CONTROLLER

Note: This list identifies the major components only. Recommended spare parts highlighted red.

K.5 Parts - Control Panel, 460V/575V Three Phase with 120V Duplex Receptacle Control Panel Parts List

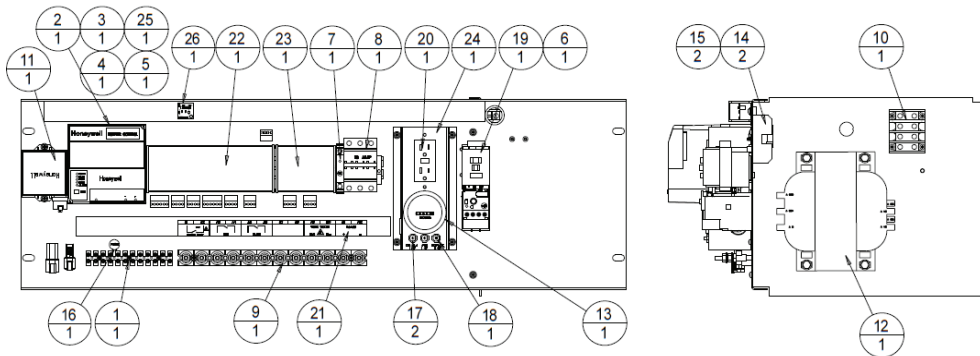

Table 24 – Control Panel Parts List

Index	Part No.	Description
1	9012-0059	TERMINAL BLOCK, 12 POLE
2	9040-0018	RELAY, FS, BURNER CONTROL
3	9040-0022	AMPLIFIER, FS, MDL
4	9040-0023	CARD, FS, PURGE TIMER, 2 SEC
5	9040-0042	BASE, RELAY, FS, RM7800 PANEL MTC
6	9040-0152	THERMAL OVERLOAD RELAY, 5.4 to 27A, 3PHASE
7	9042-0044	CB, 1 POLE 5 A
8	9042-0071	CB, 2 POLE 10 - 16A
9	9043-0004	BLOCK, TERM AAR 12 POLE C/W HDW
10	9043-0025	BLOCK, TERM 4 POLE, 600V 115A
11	9064-0021	TRFRMR, IGN, 120V PRI
12	9064-0033	TRFRMR, CONT 460/575>120V 15A/24V 4A (shown) (for configurations with 120V duplex receptacle)
13	9069-0015	METER, ELAPSED TIME HRS, 120V AC 60HZ
14	9077-0028	FUSE HOLDER, PANEL MOUNT

Index	Part No.	Description
15	9077-0031	FUSE, 1.5 AMP 600V
16	9077-0033	FUSE, RESETTABLE
17	9077-0034	CB, 1A, PNL MNT
18	9077-0035	CB, 15A, PNL MNT
19	9078-0126	CONTACTOR, 12A C/W 120V COIL
20	9079-0004	RCPT, DUPLEX 15A-125V, GFCI SMARTLOCK
21	18532	LABEL, AAR CONNECTOR, VINYL
22	18783-02	CONTROLLER, 900 HEATER
23	18784	EMS MODULE
24	18931	BRKT, FUSE & HR METER
25	18934	RESET MODULE
26	19018	PROGRAMMING KEY, CONTROLLER

Note: This list identifies the major components only. Recommended spare parts highlighted red.

K.6 Gas Train

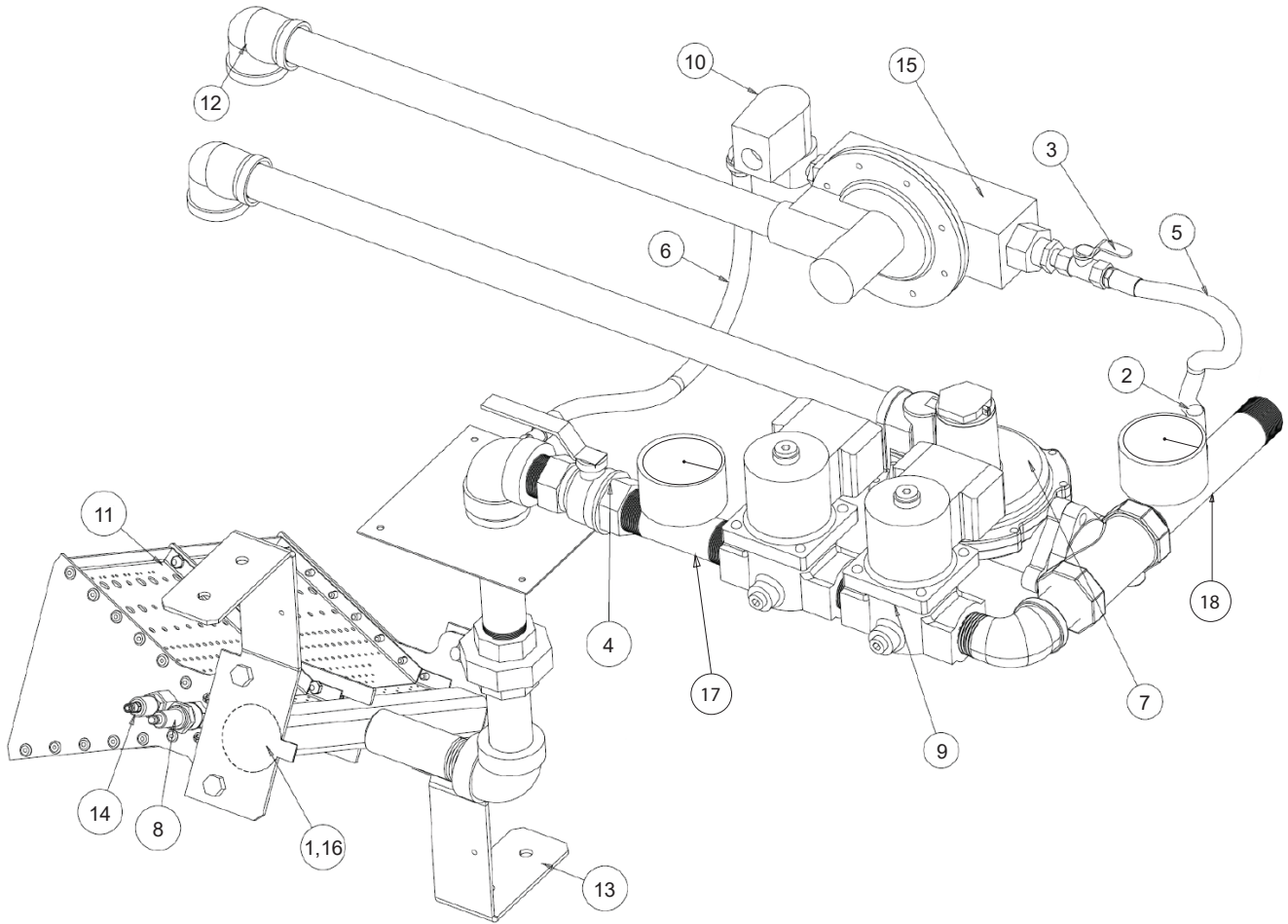

Table 25 – Parts - Gas Components

Index	Part No.	Description
1	HF19304	HTR, 2"DIA 30W 24V AC 18"L LEADS SI
2	HF9045-0085	CONN, 1/4TUBE MALE * 1/8NPTM, BR
3	HF9045-0160	VALVE, BALL 1/4" NPT 1/4 TURN
4	HF9045-1003	REGULATOR, PILOT 125PSI/9 - 13"WC
5	HF9069-1015	HOSE, PRPNE 1/4"NPTF F/SWVL* 12"L
6	HF9081-0066	REGULATOR, 12.5-20"WC (HSR)
7	HF9089-0026	VALVE, SOL, GAS, 1"NPT 120V (HONEYWELL)
8	HF14970	IGNTR, SPARK
9	HF9089-0028	VALVE, SOL, PILOT, GAS, 1/4"NPT 50CFH
11	HF11700	BURNER, HF900

Index	Part No.	Description
12	HF11712	VENT ELBOW
13	HF11739	BRKT, SUPPORT, HF 900 BURNER
14	HF14978	ROD, FLAME 3"L 1/4"NPT
15	HF16952	PILOT REGULATOR, MODIFIED
16	HF17927	SPRING WEDGE, 2"X2", SST, HF900 BURNER DEFROSTER
17	HF9069-1020	GAUGE, PRESSURE, 0-30"WC 1/8"NPT
18	HF9069-1021	GAUGE, PRESSURE, 0-30 PSI, 1/8" NPT
Not Shown	HF13142-04	CABLE ASSY, IGN 21"L P/NG HF900
	HF15165-04	CABLE ASSY, FLAME ROD 22"L P/NG HF900

Note: This list identifies the major components only. Recommended spare parts highlighted red.



# NOTES

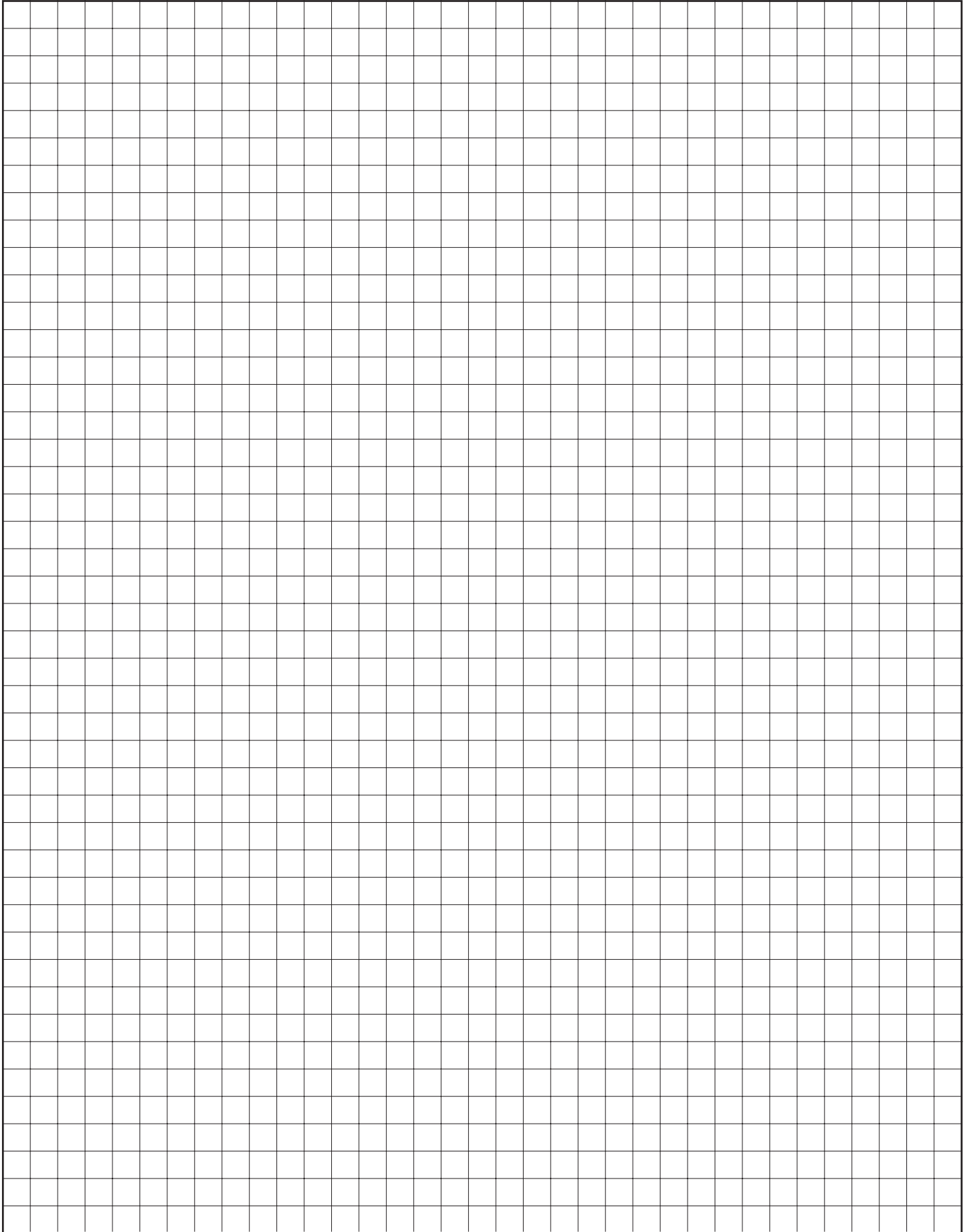

# NOTES

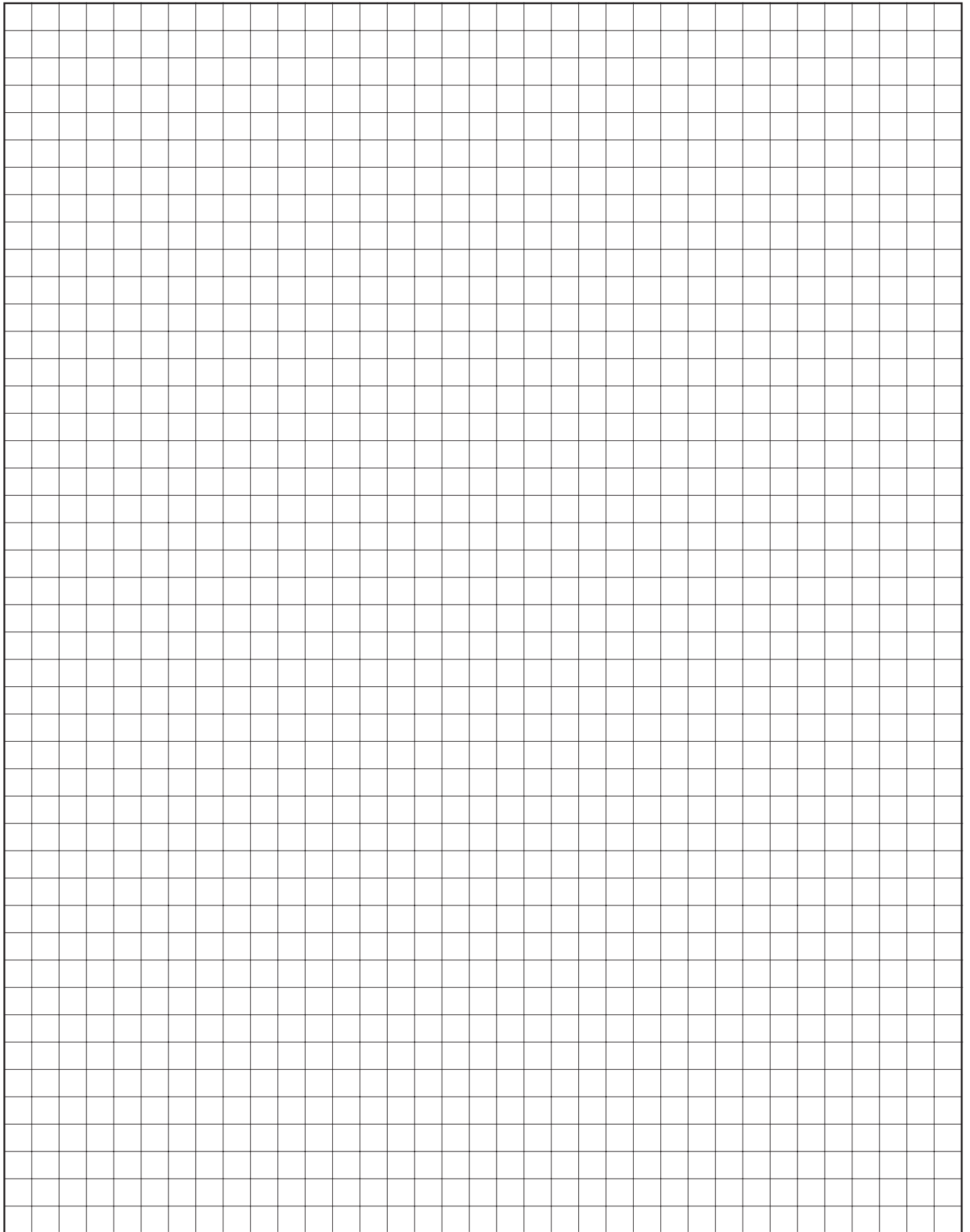

# NOTES

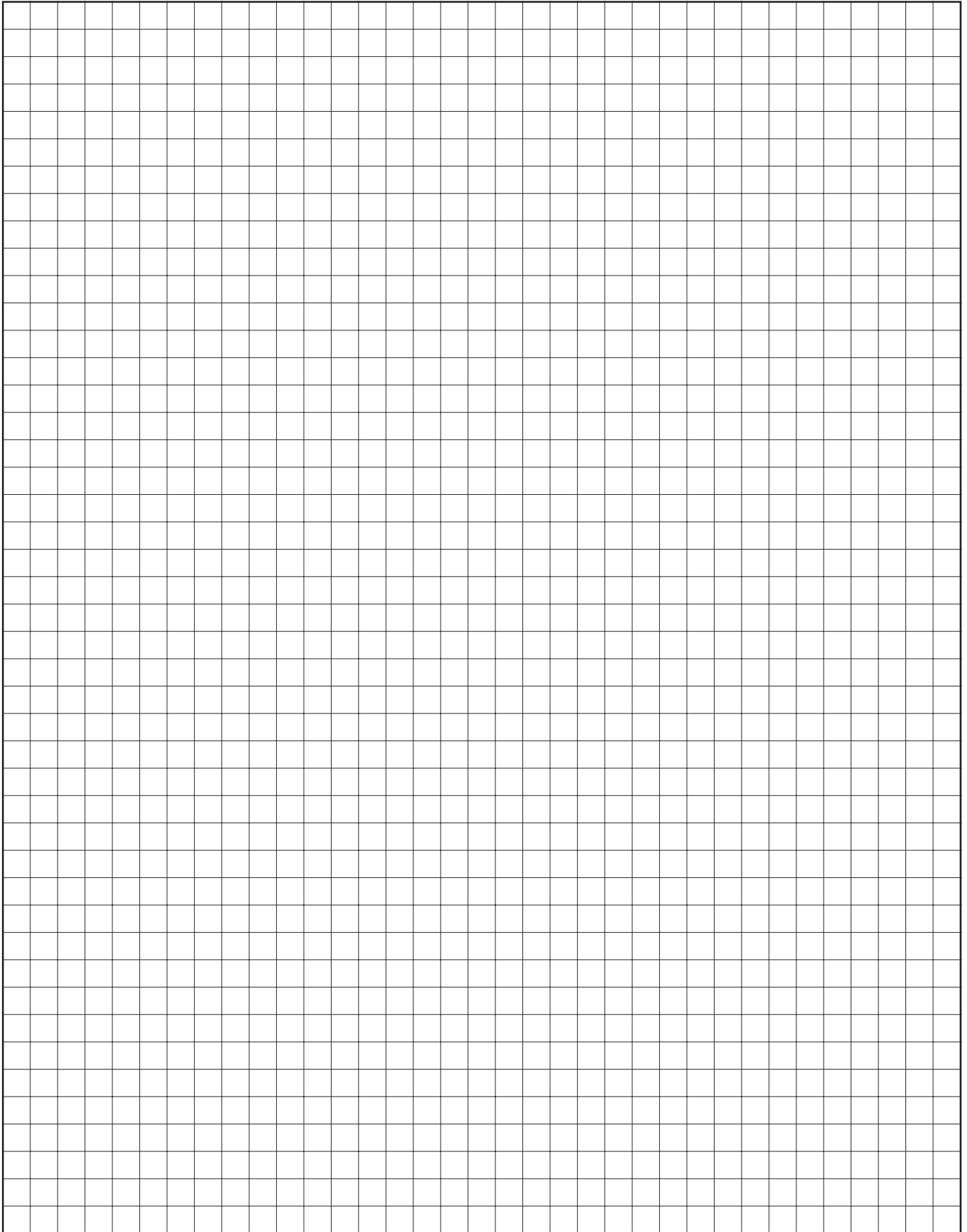



## PLEASE ADHERE TO INSTRUCTIONS IN THIS MANUAL

Failure to do so may be dangerous and may void certain provisions of your warranty.

For further assistance, please call 1.855.244.3128

**WARRANTY:** Under normal use the Company warrants to the purchaser that defects in material or workmanship will be repaired or replaced without charge (from date of shipment) for a period of:

- 84 months - SwitchBlade® Heaters
- 60 months - DC Heaters
- 36 months - DC Control Panels
- 36 months - HELLFIRE Heaters, FEB Heaters
- 12 months - All other Fastrax® Products

Any claim for warranty must be reported to the sales office where the product was purchased for authorized repair or replacement within the contract terms.

Subject to State or Provincial law to the contrary, the Company will not be responsible for any expense for installation, removal from service, transportation, or damages of any type whatsoever, including damages arising from lack of use, business interruptions, or incidental or consequential damages.

The Company cannot anticipate or control the conditions of product usage and therefore accepts no responsibility for the safe application and suitability of its products when used alone or in combination with other products. Tests for the safe application and suitability of the products are the sole responsibility of the user.

This warranty will be void if, in the judgment of the Company, the damage, failure or defect is the result of:

- Vibration, radiation, erosion, corrosion, process contamination, abnormal process conditions, temperature and pressures, unusual surges or pulsation, fouling, ordinary wear and tear, lack of maintenance, incorrectly applied utilities such as voltage, air, gas, water, and others or any combination of the aforementioned causes not specifically allowed for in the design conditions
- Or, any act or omission by the Purchaser, its agents, servants or independent contractors which for greater certainty, but not so as to limit the generality of the foregoing, includes physical, chemical or mechanical abuse, accident, improper installation of the product, improper storage and handling of the product, improper application or the misalignment of parts.

No warranty applies to paint finishes except for manufacturing defects apparent within 30 days from the date of installation.

The Company neither assumes nor authorizes any person to assume for it any other obligation or liability in connection with the product(s).

The Purchaser agrees that all warranty work required after the initial commissioning of the product will be provided only if the Company has been paid by the Purchaser in full accordance with the terms and conditions of the contract.

The Purchaser agrees that the Company makes no warranty or guarantee, express, implied or statutory, (including any warranty of merchantability or warranty of fitness for a particular purpose) written or oral, of the Article or incidental labour, except as is expressed or contained in the agreement herein.

**LIABILITY:** Technical data contained in the catalog or on the website is subject to change without notice. The Company reserves the right to make dimensional and other design changes as required. The Purchaser acknowledges the Company shall not be obligated to modify those articles manufactured before the formulation of the changes in design or improvements of the products by the Company.

The Company shall not be liable to compensate or indemnify the Purchaser, end user or any other party against any actions, claims, liabilities, injury, loss, loss of use, loss of business, damages, indirect or consequential damages, demands, penalties, fines, expenses (including legal expenses), costs, obligations and causes of action of any kind arising wholly or partly from negligence or omission of the user or the misuse, incorrect application, unsafe application, incorrect storage and handling, incorrect installation, lack of maintenance, improper maintenance or improper operation of products furnished by the Company.