

# AH Advanced Horizontal Unit Heater Pipe Mounting Kit Installation Instructions



**WARNING.** If the heater is installed on a structure that is to be transported, provide additional support for the heater during transit. The suspended weight should not exceed 250 lbs (114 kg). Refer to the unit heater owner's manual for the mounting specifications and conditions.

Check that your heater model number corresponds to the model number shown on the mounting kit carton.

## Step 1

Fasten the Column Stabilizer Bracket (#1) to the wall using the installer supplied fastening method with the slotted holes pointing away from the wall. The Column Stabilizer Bracket (#1) must be mounted at an appropriate height to support the top of the pipe.

Installer to supply three 3/8" diameter, grade 5 bolts or equivalent strength fasteners.

## Step 2

Install the Base Plate (#5) centered below the Column Stabilizer Bracket (#1) using the Expansion Bolt (#6) or installer supplied fasteners. To install the expansion bolt drill a 3/8" (9.5mm) diameter hole a minimum of 2" (51mm) deep then tap the flared end of the bolt into the hole. Using the hole in the Base Plate (#5) place it onto the Expansion Bolt and fasten to the mounting surface using a 3/8"-16 UNC Nut (#13) and 3/8" Flat Washer (#14).

## Step 3

Using the 3/8" U-Bolts (#7), 3/8" lock washers (#15) and 3/8"-16 UNC nuts (#13) fasten the Stabilizer Angle (#2) and Arm Assembly (#3) at their approximate final location on the 3" Steel Pipe. Leave nuts loose enough to permit parts to moved to final location after pipe is erected.

**Note:** One piece of 3" Sch 40 or heavier steel pipe cut to required length to be supplied by installer. Maximum length to be 25 ft (7.6 m).

## Step 4

Erect the pipe on the Base Plate (#5) that was fastened to the floor in Step 2. Using 3/8"-16 UNC X 1" bolts (#12), 3/8" flat washers (#14), 3/8" locking washers (#15) and 3/8"-16 UNC nuts (#13) fasten the Stabilizer Angle (#2) to the Column Stabilizer Bracket (#1). Position the Arm Assembly (#3) at final mounting height and tighten all fasteners.

## Step 5

Bolt AH Bracket, Mounting Attachment (#4) to the heater using 1/2"-13 UNC X 1 1/4" bolts (#8), 1/2"-13 UNC nuts (#9), 1/2" Locking Washers (#11) and 1/2" Flat Washers (#10).

## Step 6

Lift the heater into place and fasten it to the Arm Assembly (#3) using a 1/2"-13 UNC X 1 1/4" bolt (#8), 1/2" Flat Washer (#10) and 1/2" Locking Washer (#11).



**CAUTION.** This step will require more than one person due to the weight of the heater. Refer to the owner's manual for the weight of the heater.

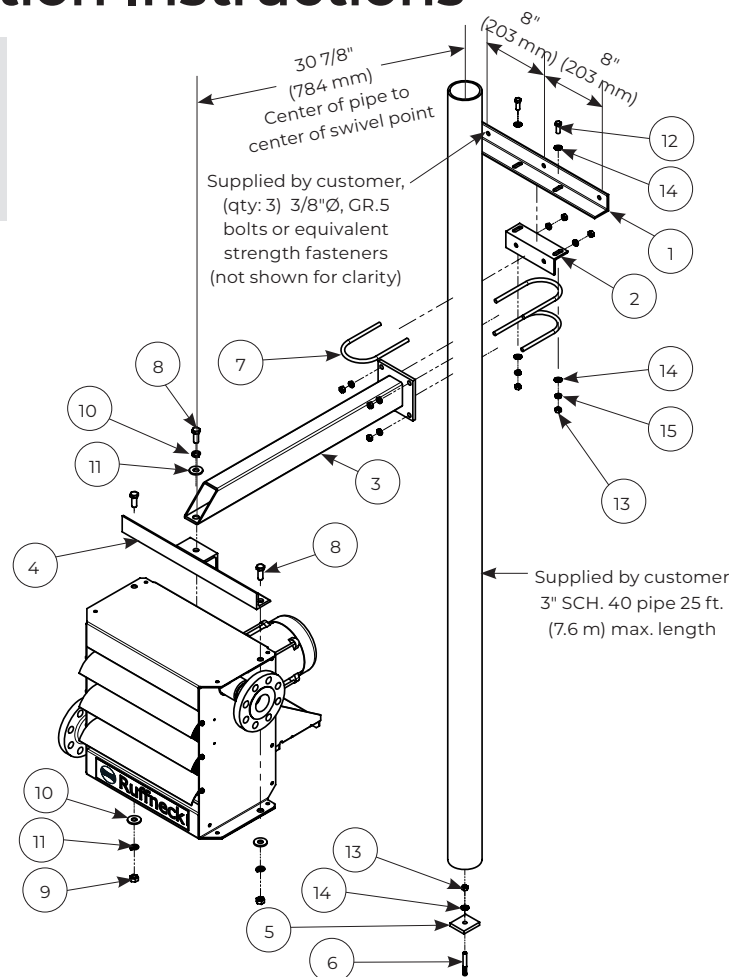

Table 1 – Contents

Item	Qty	Description	Part No.
1	1	Column stabilizer bracket	3199
2	1	Stabilizer angle	2800
3	1	Arm, Mounting	9706
4	1	AH bracket, mounting attachment	12A - 5455
			16A - 5454
			20A - 5453
			24A - 5452
5	1	Base plate	3383
6	1	Expansion bolt, 3/8" x 2 3/4"	2944
7	3	U-bolt, 3/8" UNC 92 X 114 long	3384
8	3	Bolt, 1/2"-13 UNC X 1 1/4", Pltd.	2940
9	2	Nut, 1/2"-13 UNC, Pltd.	4372
10	3	Flat Washer, 1/2" Pltd.	2941
11	3	Locking Washer, 1/2" Pltd.	4373
12	2	Bolt, 3/8"-16 UNC X 1", Pltd.	3153
13	9	Nut, 3/8"-16 UNC X 1", Pltd.	2785
14	5	Flat Washer, 3/8" Pltd.	3091
15	8	Locking Washer, 3/8" Pltd.	3159



# Ruffneck™

**PLEASE ADHERE TO INSTRUCTIONS IN THIS MANUAL**

Failure to do so may be dangerous and may void certain provisions of your warranty.

For further assistance, please call 24hr hotline: 1-800-661-8529 (U.S.A. and Canada)  
Please have model and serial numbers available before calling.

**WARRANTY:** Under normal use the Company warrants to the purchaser that defects in material or workmanship will be repaired or replaced without charge for a period of 18 months from date of shipment, or 12 months from the start date of operation, whichever expires first. Any claim for warranty must be reported to the sales office where the product was purchased for authorized repair or replacement within the terms of this warranty.

Subject to State or Provincial law to the contrary, the Company will not be responsible for any expense for installation, removal from service, transportation, or damages of any type whatsoever, including damages arising from lack of use, business interruptions, or incidental or consequential damages.

The Company cannot anticipate or control the conditions of product usage and therefore accepts no responsibility for the safe application and suitability of its products when used alone or in combination with other products. Tests for the safe application and suitability of the products are the sole responsibility of the user.

This warranty will be void if, in the judgment of the Company, the damage, failure or defect is the result of:

- Vibration, radiation, erosion, corrosion, process contamination, abnormal process conditions, temperature and pressures, unusual surges or pulsation, fouling, ordinary wear and tear, lack of maintenance, incorrectly applied utilities such as voltage, air, gas, water, and others or any combination of the aforementioned causes not specifically allowed for in the design conditions or,
- Any act or omission by the Purchaser, its agents, servants or independent contractors which for greater certainty, but not so as to limit the generality of the foregoing, includes physical, chemical or mechanical abuse, accident, improper installation of the product, improper storage and handling of the product, improper application or the misalignment of parts.

No warranty applies to paint finishes except for manufacturing defects apparent within 30 days from the date of installation.

The Company neither assumes nor authorizes any person to assume for it any other obligation or liability in connection with the product(s).

The Purchaser agrees that all warranty work required after the initial commissioning of the product will be provided only if the Company has been paid by the Purchaser in full accordance with the terms and conditions of the contract.

The Purchaser agrees that the Company makes no warranty or guarantee, express, implied or statutory, (including any warranty of merchantability or warranty of fitness for a particular purpose) written or oral, of the Article or incidental labour, except as is expressed or contained in the agreement herein.

**LIABILITY:** Technical data contained in the catalog or on the website is subject to change without notice. The Company reserves the right to make dimensional and other design changes as required. The Purchaser acknowledges the Company shall not be obligated to modify those articles manufactured before the formulation of the changes in design or improvements of the products by the Company.

The Company shall not be liable to compensate or indemnify the Purchaser, end user or any other party against any actions, claims, liabilities, injury, loss, loss of use, loss of business, damages, indirect or consequential damages, demands, penalties, fines, expenses (including legal expenses), costs, obligations and causes of action of any kind arising wholly or partly from negligence or omission of the user or the misuse, incorrect application, unsafe application, incorrect storage and handling, incorrect installation, lack of maintenance, improper maintenance or improper operation of products furnished by the Company.

Visit [www.Thermon.com](http://www.Thermon.com) to contact a Thermon representative near you.

**HEAD OFFICE:** 7171 SOUTHWEST PKWY | BUILDING 300 SUITE 200 | AUSTIN, TX | 78735 | UNITED STATES  
**RUFFNECK:** 5918 ROPER ROAD | EDMONTON, AB | T6B-3E1 | CANADA