

Explosion-Proof Duct Heater

# Type RXDF

Installation, Operation & Maintenance Instructions



## Special Notes



**CAUTION.** This symbol indicates a potentially hazardous situation, which, if not avoided, can result in personal injury or damage to the equipment.



**CAUTION.** This symbol indicates a potentially hazardous situation, which, if not avoided, may be a shock hazard.



**WARNING.** This symbol indicates an imminently hazardous situation, which, if not avoided could result in death or serious injury.

# TABLE OF CONTENTS

<b>A. Scope</b>	<b>2</b>
<b>B. General Information</b>	<b>3</b>
B.1 Description .....	3
B.2 Application .....	3
B.3 Construction .....	3
B.4 Standard Product Features .....	3
B.5 Optional Product Features .....	3
<b>C. Pre-Installation</b>	<b>3</b>
<b>D. Dimensions &amp; Installation</b>	<b>4</b>
D.1 Heater Dimensions .....	4
D.2 Installation .....	4
<b>E. Wiring</b>	<b>5</b>
<b>F. Startup &amp; Operation</b>	<b>6</b>
<b>G. Overheat Protection</b>	<b>6</b>
<b>H. Maintenance</b>	<b>6</b>
<b>I. Literature</b>	<b>7</b>
<b>J. Field Serviceability</b>	<b>7</b>

## A. SCOPE

---

This manual details the installation, operation, and maintenance instructions for type RXDF explosion-proof duct heaters.

Your RXDF explosion-proof duct heater has been CSA C/ US Certified to meet the requirements for hazardous location equipment for use in Canada and the United States. When properly maintained and serviced, you can expect years of trouble free operation.

Carefully read and follow all instructions outlined in this manual to ensure proper installation and safe operation of your heater.

## B. GENERAL INFORMATION

### B.1 Description

Type RXDF explosion-proof duct heaters are designed for heating air or gases that contain potentially explosive substances. RXDF heaters feature the unique approach to explosion-proof electric heater design, which embodies safety and reliability.

The RXDF is a factory pre-wired explosion-proof duct heater. Standard models are available in three duct sizes, with either a single or double bank of heating modules. RXDF heaters are available as standard units with T3B, T3A, or T2D hazardous area temperature codes.

### B.2 Application

The RXDF is designed specifically for heating industrial spaces where potentially explosive substances are or may be present. Typical hazardous location environments include:

- Water and sewage treatment plants
- Oil refineries
- Pulp and paper mills
- Petrochemical plants
- Grain elevators
- Paint storage booths
- Cement plants

### B.3 Construction

The RXDF explosion-proof duct heater features heavy-walled carbon steel finned tubular heating elements with electroless nickel plated finish to provide safe, efficient, low temperature heat transfer.

Standard units have a painted carbon steel duct section with mounting holes provided for attachment to the duct section.

RXDF heaters feature the unique patented **x-Max** copper-free aluminum extruded terminal housing. A track-and-trolley system and threaded covers on each end allow easy access to wiring terminal connections.

Units are suitable for mounting in a horizontal duct section only.

### B.4 Standard Product Features

- T2D, T3A, or T3B temperature code
- CSA C/US Certified for use in hazardous areas. T2D units Certified for use in Class I, Division 1 & 2, Group C & D hazardous areas. T3A units Certified for use in Class I, Division 1 & 2, Group C & D; Class II, Division 1 & 2, Group E & F hazardous areas. T3B units Certified for use in Class I, Division 1 & 2, Group C & D; Class II, Division 1 & 2, Group E, F, & G hazardous areas.
- Painted steel duct section
- Differential pressure switch (supplied loose)
- Factory installed high limit sensing thermocouple(s)

### B.5 Optional Product Features

- Transition sections
- Stainless steel duct section
- Special temperature code
- Outlet air thermostat
- Outlet air thermocouple

## C. PRE-INSTALLATION

1. Inspect the heater for possible damage due to shipping and handling. Claims for shipping damages shall be placed with the carrier.
2. Check the heater nameplates to ensure that the heater area classification and temperature code are suitable for the hazardous area classification.
3. Verify that the nameplate voltage, phase, and wattage are as ordered and are the same as the electrical power supply available.



**WARNING.** Do not connect the heater to an electrical supply voltage other than that shown on the product nameplate.



**CAUTION.** Review this manual and all drawings contained within prior to installation, wiring, or operation of the heater.

## D. DIMENSIONS & INSTALLATION

The heater must be installed by qualified personnel in strict compliance with the electrical code and hazardous locations standards.



**WARNING.** The heater must be installed in a horizontal duct section only. Improper orientation of the heater can affect the safe and reliable operation of the heater.

### D.1 Heater Dimensions

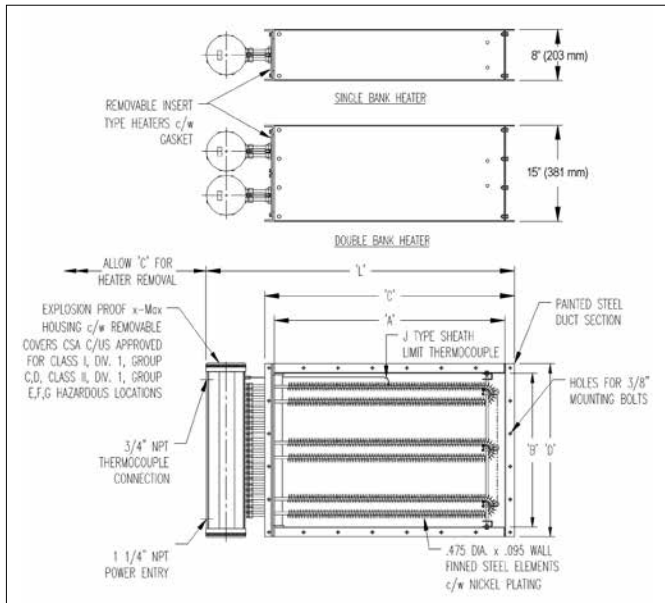

Figure 1 – RXDF Heater Dimensions

Table 1 – Heater Dimensions and Weights

Duct Size (W x H)		Dimensions										No. of Banks	Weight	
mm	in	A		B		C		D		L			kg	lbs
		mm	in	mm	in	mm	in	mm	in	mm	in			
610 x 305	24 x 12	610	24	305	12	686	27	381	15	927	36.5	1	41	90
												2	73	160
762 x 457	30 x 18	762	30	457	18	838	33	533	21	1080	42.5	1	61	135
												2	114	250
914 x 610	36 x 24	914	36	610	24	991	39	686	27	1232	48.5	1	82	180
												2	148	325

### D.2 Installation

- The heater is designed for installation in a horizontal duct with the terminal boxes at the side. Improper orientation of the duct heater could effect the safe and reliable operation of the heater.



**WARNING.** Improper orientation of the heater can affect the safe and reliable operation of the heater.



**CAUTION.** Never use the control housings for lifting or moving the heater as this can damage the heating elements and conduit.

- To install the heater, bolt the heater assembly into the customer supplied ducting system. If necessary, reinforce with duct supports to support the heater weight as shown in Table 1. Note proper orientation of heater, as shown by the "TOP" and "AIRFLOW" labels.
- An explosion-proof pressure differential switch has been supplied loose. Install the switch in a suitable location and with proper orientation. Install tubing between the switch and the duct using the appropriate port on the switch body (sensing high or low pressure). Consult manufacturer's operation instructions included with this manual.



**WARNING.** The pressure differential switch is a critical safety component. Improper installation of the switch may result in hazardous conditions.

## E. WIRING



**WARNING.** Whenever hazardous materials are present, ensure that the terminal housing covers, plugs, etc., are secured (but not over tightened) before energizing the heater.



**CAUTION.** All circuits must be in the open position before removing junction or terminal box covers.



**CAUTION.** Use supply wires suitable for 90°C. Supply wires are to be fused with appropriately sized HRC fusing.



**WARNING.** Use approved conduit and conduit seals as required by hazardous location standards.



**CAUTION.** Ensure that no power is connected to the equipment prior to making any connections.

1. The heater is factory prewired to supply terminal blocks in the heater terminal housing ready for direct connection to the power supply. The heater also contains one (1) high limit thermocouple per heating bank that must be wired to the control equipment.



**WARNING.** For double bank heaters, Heater Bank #1 is defined as the inlet bank and Heater Bank #2 is defined as the outlet bank. This distinction is important in order to ensure proper high limit set limit set points must be set in the field. Table 2 gives the maximum high limit set points for safe operation of the heater. For initial start-up, set the high limit controllers to the values indicated in Table 2 and lock in place.

2. To wire the heater to the control equipment, make the following connections at the connection points indicated on the assembly drawing:
  - 2.1 1 ¼" NPT conduit entries have been provided in each heater terminal housing for wiring the power supply and ground to the heaters. Connect the heating bank(s) to the contactor(s) in the control panel.
  - 2.2 ¾" NPT conduit entries have been provided on each heater bank for wiring the J type high limit thermocouple(s) to Certified, manual-reset high limit controller(s) in the control panel. Using appropriate thermocouple extension wire, connect the thermocouple(s) to the high limit controllers, ensuring proper connection of the positive and negative leads.

- 2.3 Connect the "Normally Open" contacts of the supplied pressure differential switch to the interlocks in the control circuit.



**WARNING.** After all connections have been made and before starting up the system, ensure that all housings, plugs, covers, etc. have been installed.

## F. STARTUP & OPERATION



**WARNING.** To ensure safe and reliable operation, do not exceed the maximum outlet temperature of 40°C and do not allow the airflow to drop below the minimum airflow shown on the product nameplate.

1. Turn on the airflow through the duct heater. Ensure that the minimum airflow, as shown on the product nameplate, is maintained at all times.
2. The field installed explosion-proof differential pressure switch may require field adjustment. Consult manufacturer's operation instructions included with this manual.



**WARNING.** The pressure differential switch is a critical safety component. Improper setting of the switch may result in hazardous conditions.

3. Apply power to the control panel.
4. Turn the control on/off switch to "ON".
5. Set the temperature controller to the desired set point. Do not exceed the maximum outlet temperature of 40°C.

6. Ensure that the temperature controller is working properly. Consult the manufacturer's operation instructions supplied with the temperature controller.
7. Except when purchasing a control panel to accompany your RXDF heater, the high limit set points must be set in the field. Table 2 gives the maximum high limit set points for safe operation of the heater. For initial start-up, set the high limit controllers to the values indicated in Table 2.



**WARNING.** To prevent unsafe operation of the heaters, do not exceed the maximum high limit set points. Operation of the heater with high limit set points greater than those shown in Table 2 creates a significant risk of explosion.

Table 2 – Maximum High Limit Set Points

Temperature Code	High Limit Set Point (°C)		
	T2D	T3A	T3B
Heater Bank #1	94	78	65
Heater Bank #2	125	100	83

## G. OVERHEAT PROTECTION

The heater is equipped one (1) high limit thermocouple per heating bank to sense the heating element sheath temperature. Each high limit thermocouple must be wired to a separate CSA C/US Certified, manual-reset high limit controller in the control panel. The set point of the controller(s) must be locked, and not exceed the values given in Table 2.

In the event of fan failure, excessive dust buildup, or restricted airflow, the heater temperature may rise, causing the limit controls to open and break the power supply to the heater.



**WARNING.** CYCLING OF THE HEATER ON THE HIGH LIMITS SHOULD NOT BE PERMITTED. Should this occur, the systems should be inspected to determine the cause of the cycling, and the condition must be corrected before regular operation is resumed.

## H. MAINTENANCE



**WARNING.** DISCONNECT ALL POWER TO THE EQUIPMENT PRIOR TO SERVICING.

1. Periodically inspect the heater installation to ensure that all connections, fitting, plugs, screws, covers, etc. are tight and free of corrosion.
2. Check the surface of the duct section and terminal boxes for dust and debris, especially after seasonal shutdowns. Clean with a blast of air or vacuum.
3. Check the surface of the finned elements for dust and debris. Clean with a blast of air.
4. Ensure that all fuses are in properly working order.
5. Maintain the pressure differential switch in accordance with the manufacturer's instructions
6. Field repair of the heater should not be undertaken. In the event that the heater must be repaired, contact the factory.

## I. LITERATURE

---

The following manufacturer's literature has been included with this manual:

- Explosion-Proof Pressure Differential Switch

## J. FIELD SERVICEABILITY

---

The RXDF explosion-proof duct heater is not field-serviceable. If your heater requires servicing, please consult the factory.

For further assistance, please call 24hr hotline: 1-800-661-8529 (U.S.A. and Canada)  
Please have model and serial numbers available before calling.

**WARRANTY:** Under normal use the Company warrants to the purchaser that defects in material or workmanship will be repaired or replaced without charge for a period of 18 months from date of shipment, or 12 months from the start date of operation, whichever expires first. Any claim for warranty must be reported to the sales office where the product was purchased for authorized repair or replacement within the terms of this warranty.

Subject to State or Provincial law to the contrary, the Company will not be responsible for any expense for installation, removal from service, transportation, or damages of any type whatsoever, including damages arising from lack of use, business interruptions, or incidental or consequential damages.

The Company cannot anticipate or control the conditions of product usage and therefore accepts no responsibility for the safe application and suitability of its products when used alone or in combination with other products. Tests for the safe application and suitability of the products are the sole responsibility of the user.

This warranty will be void if, in the judgment of the Company, the damage, failure or defect is the result of:

- Vibration, radiation, erosion, corrosion, process contamination, abnormal process conditions, temperature and pressures, unusual surges or pulsation, fouling, ordinary wear and tear, lack of maintenance, incorrectly applied utilities such as voltage, air, gas, water, and others or any combination of the aforementioned causes not specifically allowed for in the design conditions or,
- Any act or omission by the Purchaser, its agents, servants or independent contractors which for greater certainty, but not so as to limit the generality of the foregoing, includes physical, chemical or mechanical abuse, accident, improper installation of the product, improper storage and handling of the product, improper application or the misalignment of parts.

No warranty applies to paint finishes except for manufacturing defects apparent within 30 days from the date of installation.

The Company neither assumes nor authorizes any person to assume for it any other obligation or liability in connection with the product(s).

The Purchaser agrees that all warranty work required after the initial commissioning of the product will be provided only if the Company has been paid by the Purchaser in full accordance with the terms and conditions of the contract.

The Purchaser agrees that the Company makes no warranty or guarantee, express, implied or statutory, (including any warranty of merchantability or warranty of fitness for a particular purpose) written or oral, of the Article or incidental labour, except as is expressed or contained in the agreement herein.

**LIABILITY:** Technical data contained in the catalog or on the website is subject to change without notice. The Company reserves the right to make dimensional and other design changes as required. The Purchaser acknowledges the Company shall not be obligated to modify those articles manufactured before the formulation of the changes in design or improvements of the products by the Company.

The Company shall not be liable to compensate or indemnify the Purchaser, end user or any other party against any actions, claims, liabilities, injury, loss, loss of use, loss of business, damages, indirect or consequential damages, demands, penalties, fines, expenses (including legal expenses), costs, obligations and causes of action of any kind arising wholly or partly from negligence or omission of the user or the misuse, incorrect application, unsafe application, incorrect storage and handling, incorrect installation, lack of maintenance, improper maintenance or improper operation of products furnished by the Company.



**Edmonton**

1-780-466-3178

F 780-468-5904

5918 Roper Road

Alberta, Canada T6B 3E1

**Oakville**

1-800-410-3131

1-905-829-4422

F 905-829-4430

**Orillia**

1-877-325-3473

1-705-325-3473

F 705-325-2106

**Houston**

1-855-219-2101

1-281-506-2310

F 281-506-2316

**Denver**

1-855-244-3128

1-303-979-7339

F 303-979-7350