

Terminator ZT/FAK-4 and FAK 4L

Thermostat Connection In-Line
Power Kit For Use With
TubeTrace® Bundles

INSTALLATION PROCEDURES



Terminator ZT/FAK-4 and FAK 4L

The following installation procedures are suggested guidelines for the installation of the Terminator ZT/FAK-4 and FAK 4L Thermostat Connection In-Line Power Kit.

Receiving, Storing and Handling

1. Inspect materials for damage incurred during shipping.
2. Report damages to the carrier for settlement.
3. Identify parts against the packing list to ensure the proper type and quantity has been received.
4. Store in a dry location.

Terminator ZT/FAK-4 and FAK-4L Kit Contents



Item	Quantity	Description										
1	1	Expediter Assembly: Flat Mount Base, Grommet, Threaded Grommet Compressor, and Support Cap with O-Ring										
2	1	Junction Box Lid										
3	1	Junction Box Base with O-Ring and M25 Dust Cap										
4	1	Expediter Nut										
5	1	Thermostat w/ Terminal Blocks (Refer to terminal specifications for maximum allowable wire size)										
		<table border="1"> <thead> <tr> <th>Thermostat Type</th> <th>Control Range</th> </tr> </thead> <tbody> <tr> <td>ZT-C-100</td> <td>0°C to +100°C</td> </tr> <tr> <td>ZT-C-200</td> <td>0°C to +200°C</td> </tr> <tr> <td>ZT-C-300</td> <td>0°C to +300°C</td> </tr> <tr> <td>ZT-C-500</td> <td>20°C to +500°C</td> </tr> </tbody> </table>	Thermostat Type	Control Range	ZT-C-100	0°C to +100°C	ZT-C-200	0°C to +200°C	ZT-C-300	0°C to +300°C	ZT-C-500	20°C to +500°C
Thermostat Type	Control Range											
ZT-C-100	0°C to +100°C											
ZT-C-200	0°C to +200°C											
ZT-C-300	0°C to +300°C											
ZT-C-500	20°C to +500°C											
6	1	Junction Box Cord										
7	1	In-Line Splice Cover (Top)										
8	1	In-Line Splice Cover (Bottom)										
9	1	Heat Reflective Tape										
10	3	RTV Sealant Tube										
11	1	Glass Fiber Tape										
12	1	Silicone Gasket										
13	1	Self-Vulcanizing Tape										
14	1	Blind Plug										

Terminator ZT Certifications/Approvals

IP66-60°C ≤ Ta ≤ +50°C T5, 100°C; -60°C ≤ Ta ≤ +40°C T6, 85°C Ordinary & Hazardous Locations

FMG 10.0022X Ex db eb IIC T5-T6, Ex tb IIIC T100°C-T85°C

1725 Ex II 2 GD Ex db eb IIC T5-T6, Ex tb IIIC T100°C-T85°C FM10ATEX0058X

Dimensions

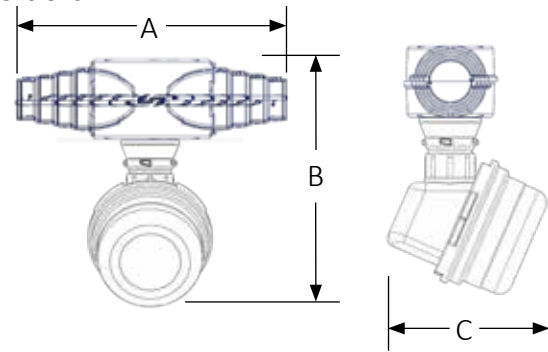

	A mm (inch)	B mm (inch)	C mm (inch)
Terminator ZT/ FAK-4	279 mm (11")	289 mm (11-3/8")	185 mm (7")
Terminator ZT/ FAK-4L	489 mm (19-1/4")	305 mm (12")	185 mm (7")

Required: Order Separately for each heater to be fabricated. PETK Power and End Termination Kits (one req'd. per heater)

- PETK-1 for BSX, RSX, VSX-HT
- PETK-2 for KSX, HTSX
- PETK-3-ZT for FP, HPT

Tools Required



The Terminator ZT/FAK-4 and FAK-4L Thermostat In-Line Power Kit is designed to provide accurate control with the ZT thermostat and make a waterproof seal over the end of TubeTrace and terminate Thermon electric heat trace in an approved Terminator junction box. Review Instructions prior to installation. Kit will make one connection.

Installation Precautions

- Keep ends of bundles, heat tracing and kit components dry before and during installation.
- To minimize the potential for arcing on electrical heat tracing caused by product damage or improper installation, use appropriate ground-fault circuit protection.
- Installation must comply with Thermon requirements and be installed in accordance with any applicable national and local codes.
- Component approvals and performance ratings are based on the use of Thermon specified parts only. User supplied power connection fittings must be listed or certified for intended use.
- De-energize all power sources before opening enclosure.
- Individuals installing these products are responsible for complying with all applicable safety and health guidelines. Proper personal protective equipment, or PPE, should be utilized during installation. Contact Thermon if you have any additional questions.

INSTALLATION PROCEDURES

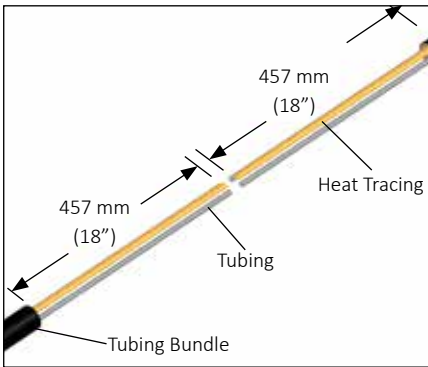

1. Remove outer jacket and insulation from tubing bundle approximately 457 mm (18") from end of the tubing bundle.



Do not cut or damage the heat trace or sampling tube.

CAUTION (Found on TubeTrace SE/ME bundles)

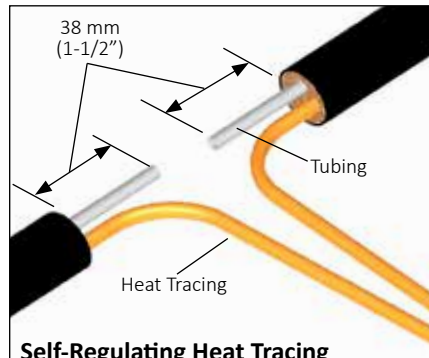

Self-Regulating Heat Tracing

2. Trim tubing to within 38 mm (1-1/2") of the end of the insulation. If self regulating heat trace proceed to step 3. For Zone-type heat trace continue with identification of bus connection on step 2a.

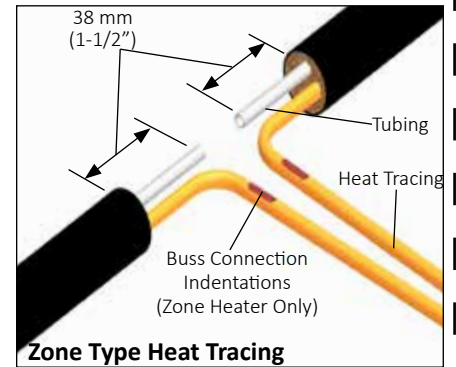

Zone Type Heat Tracing

2a. Strip back bundle insulation 38 mm (1-1/2") to 76 mm (3") beyond bus connection indentation of each heat tracing. If bus connection indentation is less than 305 mm (12") to 381 mm (15") from end of the heat tracing, proceed stripping the bundle insulation to the next indentation. Trim tubes so the bus connection indentation on each meet.

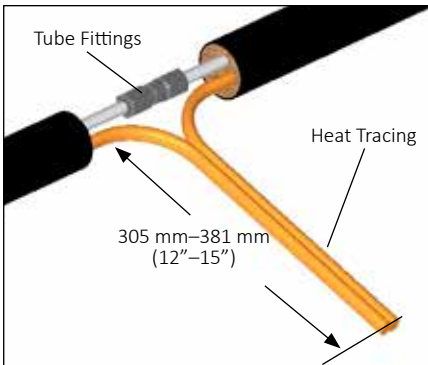

3. Make tube fitting connections with appropriate fittings (provided by others). Test fittings for leaks before proceeding.

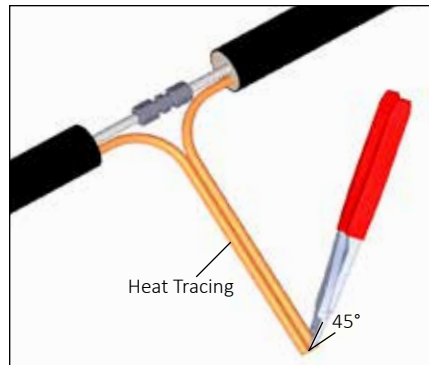

4. Cut the ends of the cable at an angle to aid in piercing grommet.

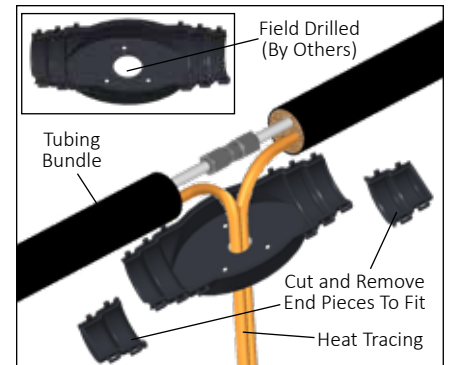

5. Cut splice cover ends to match outside diameter of tubing bundle. Field drill expediter base holes.

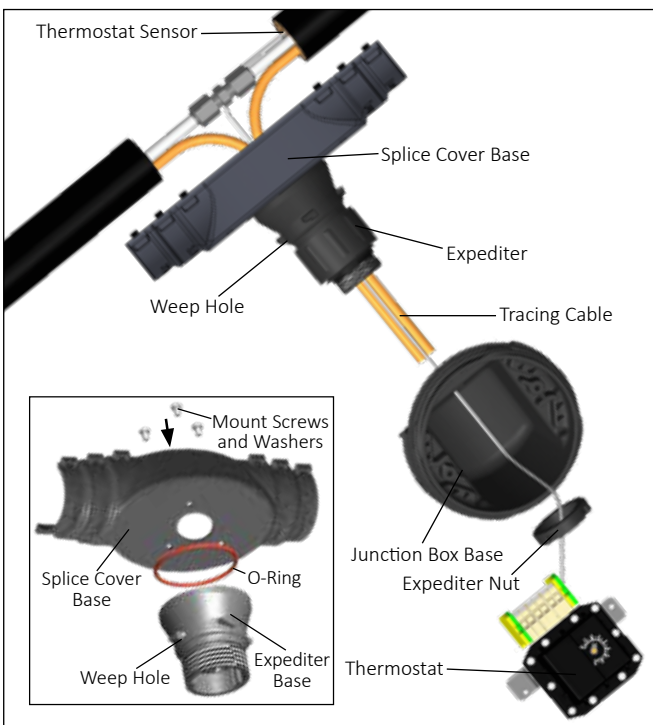

6. Route thermostat bulb through expediter nut and expediter opening in junction box base. If necessary, apply lubricant (user supplied) to the end of thermostat bulb. Slide through conical grommet hole. Insert the tracing cables through conical grommet holes and punch out weep hole. Mount expediter base with o-ring to the splice cover base using (3) M5 mounting screws and lock washers.

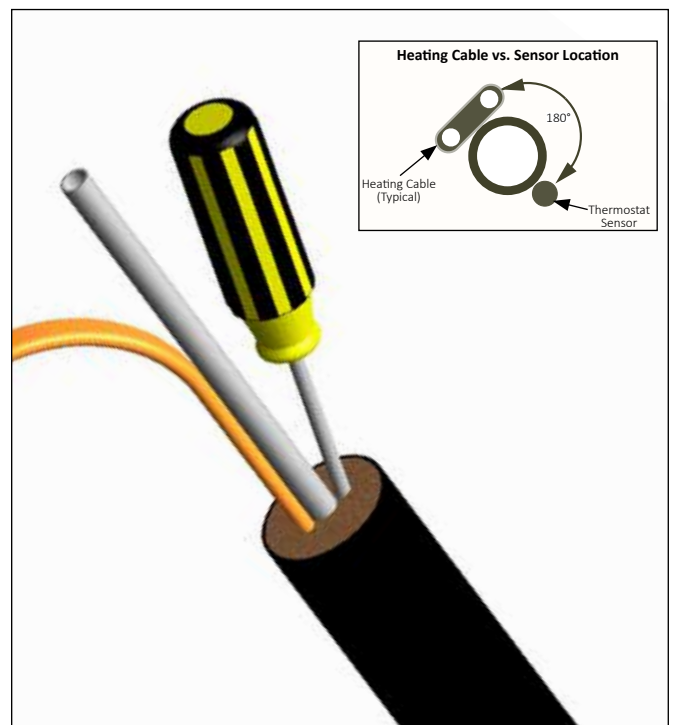

7. Create a gap between the insulation and the tube with a screw driver for the sensor and place the sensor inside.

Terminator ZT/FAK-4 and FAK 4L

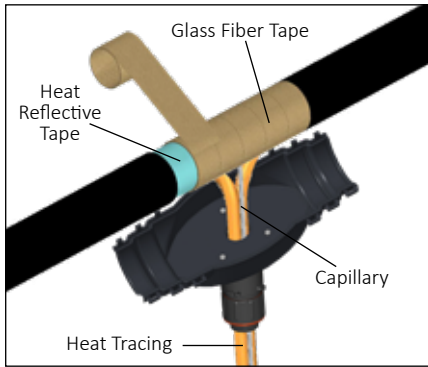

8. Wrap tube and heat trace with 1 pass of reflective tape (25% overlap), then wrap with 3 passes of glass fiber tape (50% overlap), or until fiber tape is equal to original bundle insulation thickness.

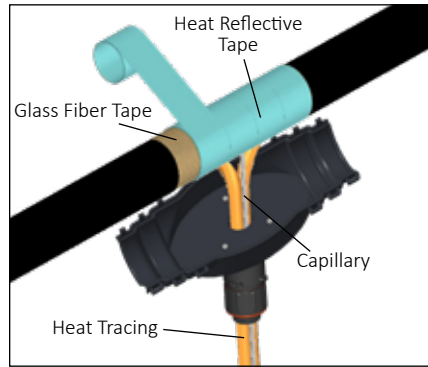

9. Complete with additional passes of heat reflective tape.

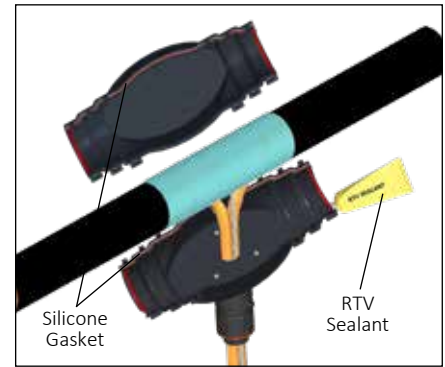

10. Install silicone gasket and cut off excess. Apply RTV sealant to both halves.

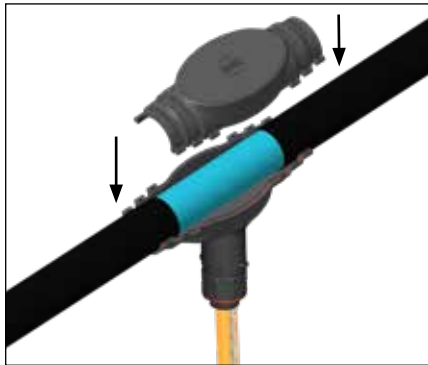

11. Assemble splice cover top, tubing bundle, and splice cover base together as shown. Snap together firmly. Inspect ends of tubing splice cover for snug fit. Apply additional RTV sealant where needed.



12. Apply self-vulcanizing tape around bundle jacket and work up over FAK ends.

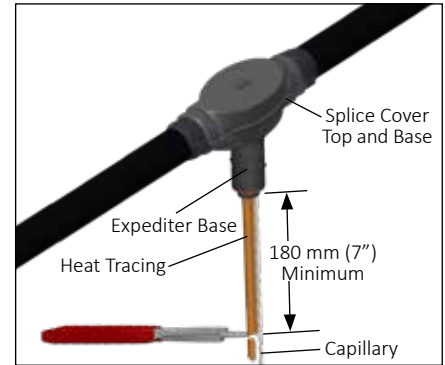

13. Trim heat tracing to 180 mm (7") minimum from expediter base.

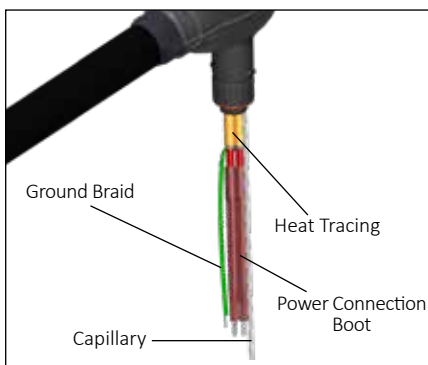

14. Terminate heat tracing with appropriate PETK termination kit. Refer to PETK installation instructions (purchase separately) for details not addressed here.

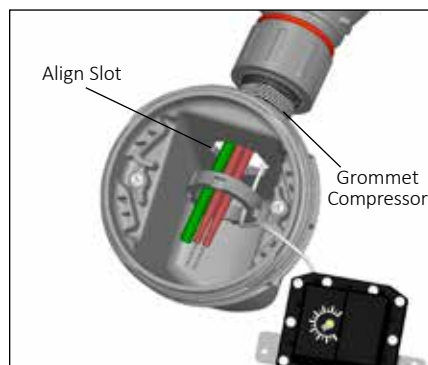

15. Mount junction box on expediter making sure to align slots to properly orient junction box base. Tighten nut with Terminator-LN-Tool.

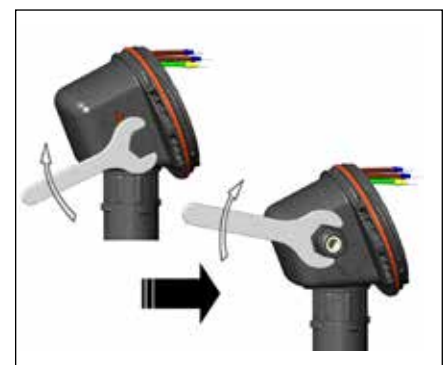

16. Remove M25 dust cap. Install M25 power gland (order separately) and M25 blind plug.

INSTALLATION PROCEDURES



17. Install thermostat and complete system wiring. Terminal set screws shall be tightened to a torque value of 1.4 Nm (12.4 lb-in). See step 17 for wiring details. Set thermostat at desired setpoint.

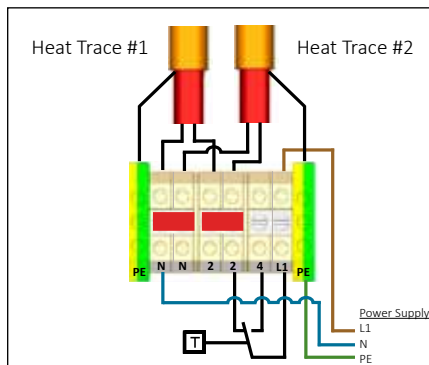

18. Wiring Details: Thermostat Connection (1 or 2 Heating Cables)

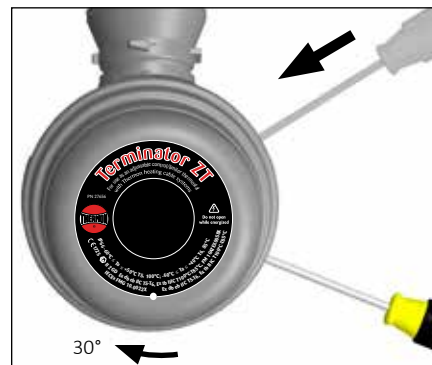

19. Install junction box lid and twist hand tight. Insert screwdriver into ratchet slot located on side of junction box base to tighten. Use screwdriver ratchet on junction box lid. Lid will rotate 30°. To remove lid, repeat steps but in opposite direction.



20. Completed Terminator ZT/FAK-4/4L power/thermostat assembly for TubeTrace Type SE/ME Bundle (Installation shown is to feed power in the middle of a TubeTrace bundle. Many installations will be near the end of a TubeTrace bundle.) Install bundle clamps (order separately) 300 mm before and after In-line power kit.

