



# PRODUCT DATASHEET

# T-3

## HEAT TRANSFER COMPOUND

### APPLICATION

T-3 heat transfer compound creates an efficient thermal bond between a steam or electric heater and process pipes or equipment. A single Thermonized steam tracer utilizing Thermon's heat transfer compound is more cost effective than a contoured clamp-on jacket and has the equivalent performance of three (or more) bare tracers.

T-3 is typically utilized for applications with maximum exposure temperatures of 454°C (850°F). To minimize waste and speed installation, use Thermon's ChannelTrace™ system featuring TFK channels. The ChannelTrace system provides protection prior to installation of thermal insulation and invites no special curing procedure for the T-3 heat transfer compound. (Refer to the back of this specification sheet for details.)



### SPECIFICATIONS/RATINGS

T-3-1 .....	3.79-liter (1-gallon) pail
T-3-5 .....	18.93-liter (5-gallon) pail
Maximum exposure temperature (ASTM C447)	454°C (850°F)
Minimum exposure temperature .....	-196°C (-320°F)
Minimum installation temperature .....	0°C (32°F)
Heat transfer coefficient, $U_t$ , tracer to pipe wall	114-227 W/m <sup>2</sup> · °C (20-40 Btu/hr · °F · ft <sup>2</sup> )
Nominal electrical resistivity .....	0.86 ohms-cm (0.34 ohms-inch)
Shelf life (unopened).....	18 months
Bond Strength (ASTM D1002).....	> 1380 kPa (> 200 lbs/in <sup>2</sup> )
Water Soluble Chlorides (ASTM C1218) .....	< 100 ppm
Water-soluble .....	yes

### BENEFITS

- Increase heat transfer rates significantly over bare tracing, reducing number of tracers and steam traps
- Fewer steam tracers reduce installation time; ChannelTrace eliminates waste
- Water-soluble for easy cleanup
- Requires no special curing procedure for tracing under TFK channels

### DESCRIPTION

T-3 is a heat transfer compound that hardens when cured.

### OPTIONS

TFK steel channel provides additional protection for a Thermonized tracer prior to the insulation of the pipe or equipment.

Banding and tools to secure steam tracing (TFK channel and/or tubing) to pipe or equipment.

**European Headquarters:** Boezemweg 25 · PO Box 205 · 2640 AE Pijnacker · The Netherlands · Phone: +31 (0) 15-36 15 370  
**United States:** 100 Thermon Dr · PO Box 609 · San Marcos, TX 78667-0609 · Phone: 512-396-5801 · 1-800-820-4328  
 For the Thermon office nearest you visit us at [www.thermon.com](http://www.thermon.com)



**PRODUCT DATASHEET**  
**T-3**  
**HEAT TRANSFER COMPOUND**

**TYPICAL STEAM TRACING SYSTEM**

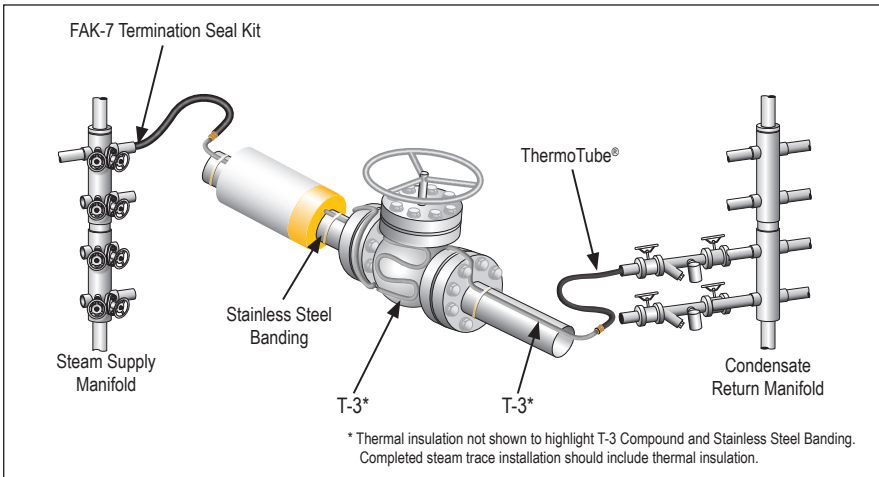

**BASIC ACCESSORIES**



**Stainless Steel Banding** used to secure tracer to piping.

**T2SSB** (.50" x .020") for 3/8" and 1/2" O.D. tube tracers.

**T3SSB** (.50" x .030") for 3/4" and 1" O.D. tube tracers and NPS pipe tracers.

**T34PB-CR** crimp seals for fastening tensioned banding.

**C001** banding tool for applying tension to T2SSB or T3SSB banding.

**1950A** crimping tool for T34PB-CR seals.

**TFK CHANNEL SPECIFICATIONS**

Nominal TFK Channel Dimensions (See Cross Section Below)					
Catalog Number	Width mm (in)	Height mm (in)	Length m (ft)	Thickness mm (in)	Channel Material
TFK-4	30 (1.18)	21 (.84)	1.2 (.04)	1.0 (.04)	Rigid Galvanized Steel
TFK-6	51 (2.00)	25 (1.00)	1.2 (.04)	0.7 (.03)	Flexible Stainless Steel
TFK-7	41 (1.62)	25 (1.22)	1.2 (.04)	1.0 (.04)	Rigid Galvanized Steel
TFK-8	17 (0.66)	19 (.75)	1.2 (.04)	1.0 (.04)	Rigid Galvanized Steel
TFK-9	64 (2.50)	44 (1.75)	1.2 (.04)	1.6 (.06)	Rigid Galvanized Steel

**Note:** Galvanized TFK channels are used up to 210°C (410°F). Use optional stainless steel channels for higher temperatures.

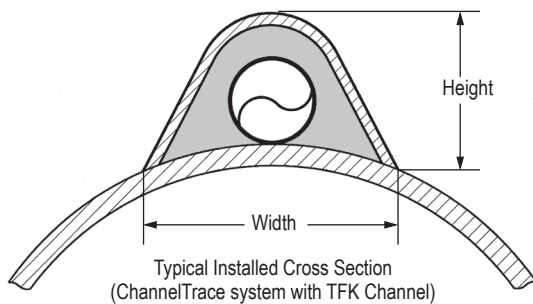

**TFK Channels for ChannelTrace Systems**

**TFK-4** for 3/8" or 1/2" O.D. tubing.

**TFK-6** flexible stainless steel for 3/8" - 3/4" tubing.

**TFK-7** for 3/4" O.D. tube or 1/2" NPS pipe tracers.

**TFK-8** for 3/8" tubing on small process lines.

**TFK-9** for 1" O.D. tube or 1" NPS pipe tracers.

(Galvanized steel is standard for rigid channels—contact Thermon for optional stainless steel)

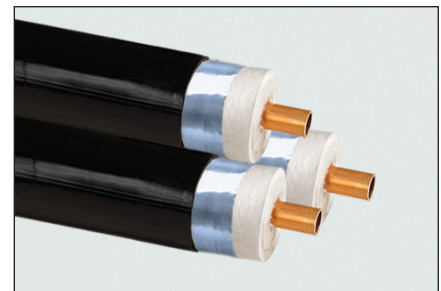

**ThermoTube** pre-insulated tubing used for steam supply and condensate return lines. Available in various materials and ratings. See Form TSP0009 for more info.