

# SafeTrace™

## Isolated Steam Tracers

### INSTALLATION PROCEDURES



The following installation procedures are suggested guidelines for the installation of SafeTrace BTS, SLS-IT and DLS-IT tracers. They are not intended to preclude the use of other methods and good engineering or field construction practices.

## Receiving, Storing and Handling

1. Inspect materials for damage incurred during shipping. Report damages to the carrier for settlement.
2. Identify the SafeTrace tubing to ensure the proper type and quantity has been received. Boxes and reels are marked on the outside with the SafeTrace part number, length, product description, weight and customer purchase order number. Compare information on box or reel with packing slip and purchase order to verify receipt of correct shipment.
  - Lengths shorter than 30 meters (100 feet) are shipped in heavyweight cardboard boxes.
  - Lengths greater than 30 meters (100 feet) are shipped on nonreturnable wooden reels.
3. The ends of SafeTrace tubing are factory-sealed to prevent dirt, moisture and insect intrusion. As a preventive measure, keep ends sealed until final connections are made. Cut ends may be temporarily sealed with plastic wrap and tape.
4. Cardboard boxes and wooden reels of product should be stored indoors away from standing water. However, wooden reels may be stored outdoors using a protective covering.
5. SafeTrace is shipped with the end of the tubing strapped to the side of the wooden reel. Use caution when releasing the end of the tracer from the reel as it is under tension and may recoil when released.

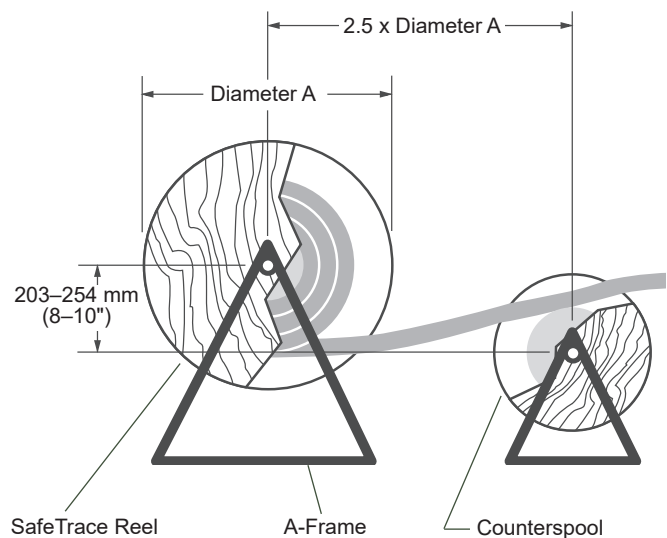
## Surface Preparation

1. Verify that the process piping has been pressure-tested prior to installing SafeTrace tubing. Repair all leaks before beginning installation of tracer tubing.
2. Surface areas where SafeTrace is to be installed must be reasonably clean. Remove dirt, rust and scale with a wire brush and oil and grease films with a suitable solvent.

## Tracer Layout

1. Determine circuit lengths and number of fittings prior to uncoiling the SafeTrace tubing since uncoiling and recoiling will “work harden” the tubing.
2. For long straight piping runs, a 300 mm (12 in) diameter expansion loop must be provided at 18 to 30 meter (60–100 ft.) intervals.
3. To uncoil and straighten the tubing, anchor the loose end of the tubing on a flat surface and roll the hand coil or shipping reel. If additional straightening is needed, apply tension to the tube.
4. Wooden spools of SafeTrace containing long lengths of tubing can be placed on a freewheeling A-frame as shown in Illustration A below. To “payout” the SafeTrace tubing, place the reel containing the tubing on the A-frame allowing the tracer tubing to freely spool from the bottom of the reel.
5. Straighten the tubing by utilizing a counterspool located in front of the reel containing the tracer tubing (see Illustration A). The counterspool should be located at a distance of  $2\frac{1}{2}$  times the diameter of the SafeTrace reel. Include a vertical offset of 203 to 254 mm (8–10 inches) between the reel centers.

**Illustration A: Tracer Payout**



## Installation on Straight Run Piping

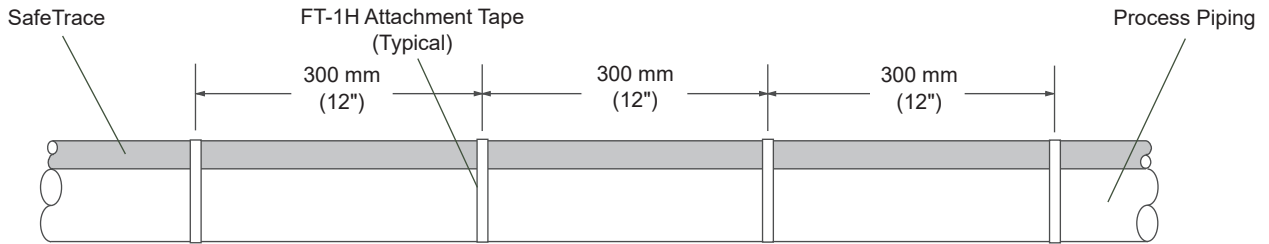
1. Install SafeTrace in accordance with Illustrations B and C below. Run the tubing parallel and in direct contact with the process piping where possible. If more than two tracers are used, they should be equally spaced circumferentially around the pipe.
2. For ease of installation and maintenance, the SafeTrace tubing should be located on the most accessible surface of the process piping. Tracer location does have an effect on heat transfer delivery; however, choosing a location convenient for installation and maintenance generally outweighs any heat transfer improvement provided by optimizing tracer location.

3. Attach SafeTrace to the process piping by utilizing 2½ wraps of Thermon's FT-1H attachment tape. Tubing should be firmly secured to the piping on 300 mm (12 in) centers to provide consistent heat transfer delivery. Refer to Tables 1 and 2<sup>1</sup> below to calculate the number of rolls of FT-1H attachment tape<sup>2</sup> required based on the pipe diameter. Use Table 1 for BTS installations and Table 2 for SLS-IT and DLS-IT installations.

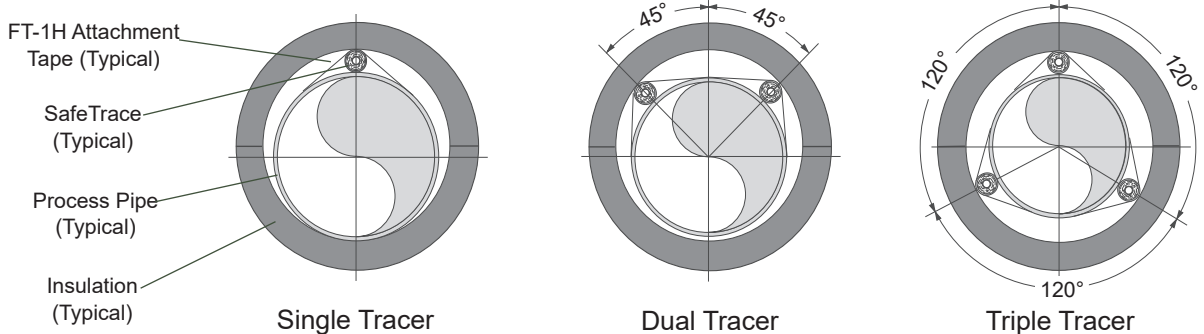
### Notes

1. Tables 1 and 2 assume circumferential bands every 300 mm (12 in) along the length of the process piping.
2. FT-1H attachment tape is 19 mm (¾") wide by 55 m (180') long with a maximum exposure temperature of 260°C (500°F).

**Illustration B: Tracer Attachment**



**Illustration C: Tracer Location**



**Table 1: FT-1H Attachment Tape Allowance for BTS**

Pipe Size mm (in)	40 (1.5)	50 (2)	80 (3)	100 (4)	150 (6)	200 (8)	250 (10)	300 (12)	350 (14)	400 (16)	450 (18)	500 (20)	600 (24)	750 (30)
<b>Meters of Pipe/Roll</b> m (ft)	33.5 (110)	29 (95)	21.3 (70)	16.8 (55)	10.7 (35)	9.1 (30)	7.6 (25)	6.1 (20)	5.8 (19)	4.9 (16)	4.6 (15)	4 (13)	3.4 (11)	2.7 (9)

**Table 2: FT-1H Attachment Tape Allowance for SLS-IT and DLS-IT**

Pipe Size mm (in)	40 (1.5)	50 (2)	80 (3)	100 (4)	150 (6)	200 (8)	250 (10)	300 (12)	350 (14)	400 (16)	450 (18)	500 (20)	600 (24)	750 (30)
<b>Meters of Pipe/Roll</b> m (ft)	29 (95)	24.4 (80)	18.3 (60)	15.2 (50)	10.7 (35)	9.1 (30)	7 (23)	6.1 (20)	5.5 (18)	4.9 (16)	4.5 (14)	4 (13)	3.4 (11)	2.7 (9)

## Installation on Flanges and Elbows

1. Install SafeTrace in accordance with Illustrations D and E below. Secure SafeTrace to process piping using FT-1H attachment tape as described on page 3.
2. A 300 mm (12 in) diameter expansion loop must be provided at 18 to 30 meter (60–100) intervals for long straight piping runs. Where possible, loops on horizontal runs should be placed on a horizontal plane to avoid trapping water during shutdown periods.
3. SafeTrace tubing must maintain contact with the flange when bending around pipe flanges. Tubing should be placed on a horizontal plane where possible. For additional heat at flanges, SafeTrace may be looped 360° around the pipe on each side of and adjacent to the flange.
4. SafeTrace tubing must be bent so there is no strain on the fitting after the tubing is installed. The cross-sectional area of SafeTrace should not be flattened, kinked or wrinkled. Refer to

the suggested recommendations from the manufacturer supplying the tubing bender. Generally a radius of four to five times the tube diameter is recommended. Refer to Table 3 for the minimum acceptable bending radius for each SafeTrace type.

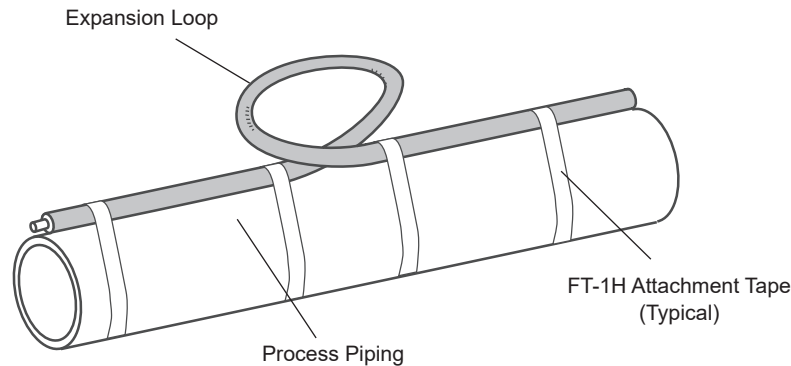
**Table 3: SafeTrace Bending Allowance<sup>1</sup>**

Catalog Number	Tube Dia. O.D. mm (in)	SafeTrace O.D. mm (in)	Min. Bend Radius <sup>2</sup> mm (in)
BTS	10 (3/8)	12 (1/2)	50 (2)
BTS	12 (1/2)	16 (5/8)	60 (2)
SLS-IT	10 (3/8)	19 (3/4)	80 (3)
DLS-IT	10 (3/8)	25 (1)	100 (4)

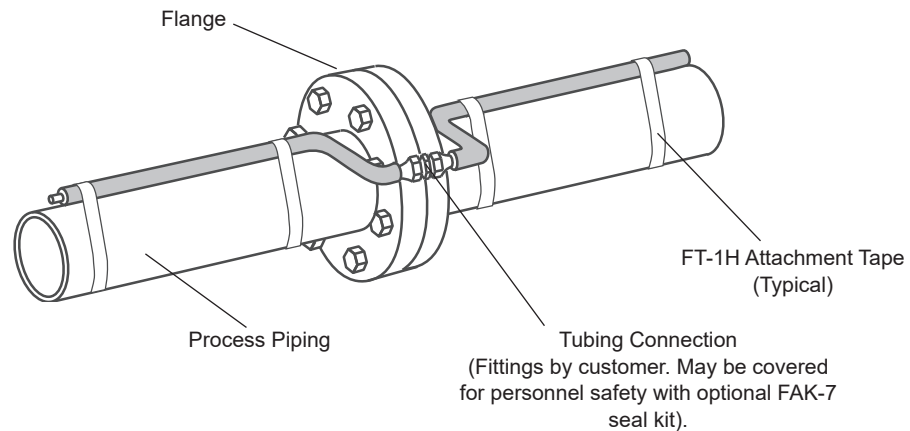
**Notes**

1. Make bends with a mechanical tubing bender. Other types of benders can also be used if care is taken to prevent deforming or flattening of the tube.
2. The bending radius for each SafeTrace type is based on the outside diameter of the safety yellow jacket.

**Illustration D: Expansion Loop Detail**



**Illustration E: Pipe Flange Detail**



### Installation on Valves and Pumps

1. Install SafeTrace in accordance with Illustrations F and G below. Secure tubing to valves and pumps using FT-1H attachment tape as described on page 3.
2. Install SafeTrace tubing on valves and pumps in the form of hairpin loops so that the tracer makes the least amount of complete circles. SafeTrace bends should be made in compliance with the procedures described on page 4.
3. The outside diameters of SLS-IT and DLS-IT prevent the tubing from being installed in a serpentine pattern on valves and pumps. Depending on the level of heating required, SafeTrace could simply pass by or be looped once around the equipment. BTS may also be substituted in many applications around valves, pumps and equipment. As an alternate, strip the jacket and insulation from the SLS-IT or DLS-IT to allow for a smaller bending radius and use 1-inch pieces as isolation sections as shown in Illustration G.

Refer to Table 4 for estimated SafeTrace requirements for installation on valves.

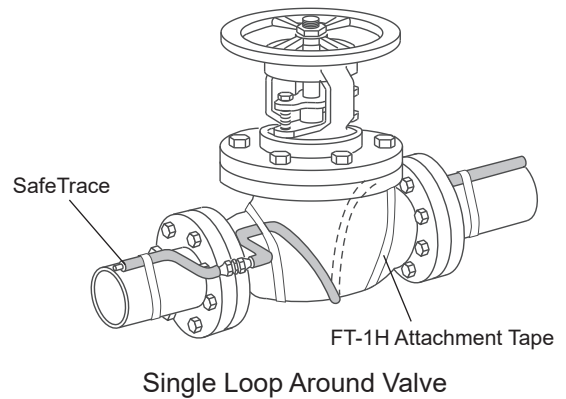
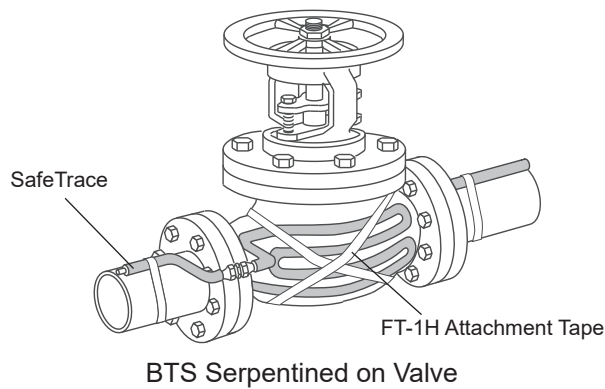
**Table 4: Valve Allowance<sup>1</sup>**

Nominal Valve Size mm (in)	Pass by Valve m (ft)	Loop Once Around Valve m (ft)	BTS 10 mm (3/8") mm (ft)	BTS (12 mm) (1/2") m (ft)
50 (2)	0.23 (0.75)	0.5 (1.6)	0.9-1.5 (3-5)	0.9-1.2 (3-4)
80 (3)	0.29 (0.95)	0.6 (2.1)	1.2-3.1 (4-7)	1.2-1.5 (4-5)
100 (4)	0.30 (1.00)	0.7 (2.4)	1.8-3.0 (6-10)	1.5-2.1 (5-7)
150 (6)	0.41 (1.34)	1.0 (3.3)	2.7-4.6 (9-15)	2.1-3.4 (7-11)
200 (8)	0.42 (1.38)	1.2 (3.9)	3.7-6.1 (12-20)	2.7-4.6 (9-15)
250 (10)	0.46 (1.50)	1.4 (4.6)	4.6-7.6 (15-25)	3.0-6.1 (10-20)
300 (12)	0.50 (1.65)	1.6 (5.3)	5.5-9.1 (18-30)	4.6-7.6 (15-25)

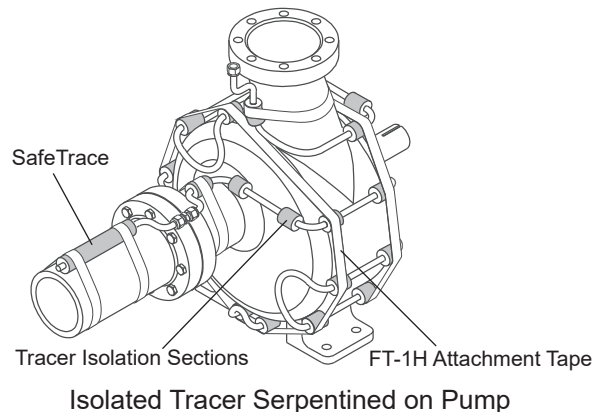
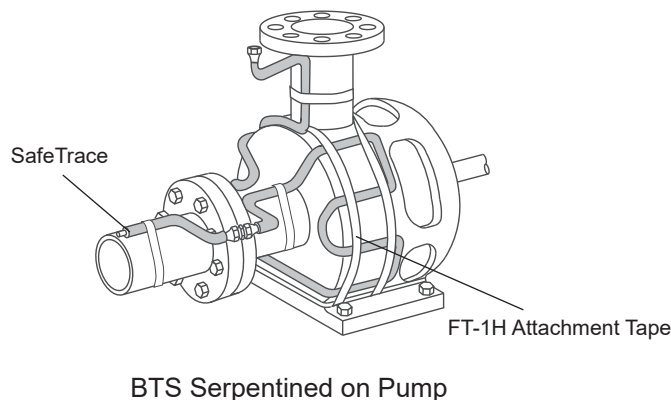
**Note**

1. Refer to the minimum bend radius for each SafeTrace type on page 4. For SLS and DLS installations, BTS may be substituted around valves, pumps and equipment.

**Illustration F: Typical Valve Detail**

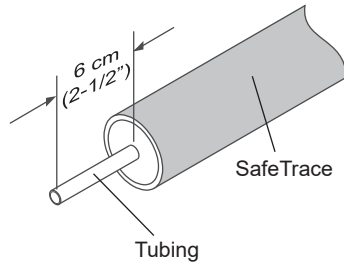


**Illustration G: Typical Pump Detail**

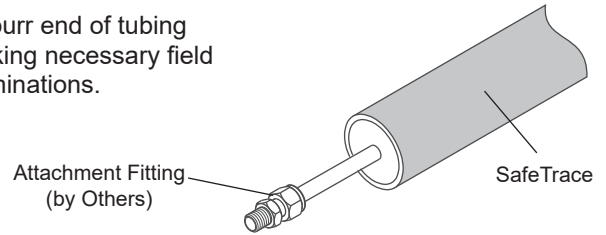


### Illustration H: FAK-7 End Seal Kit Fabrication

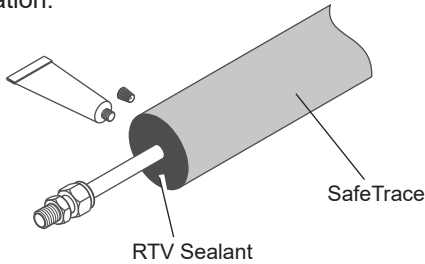
1. Remove 6 cm (2½") of the yellow jacket and insulation from the tubing.



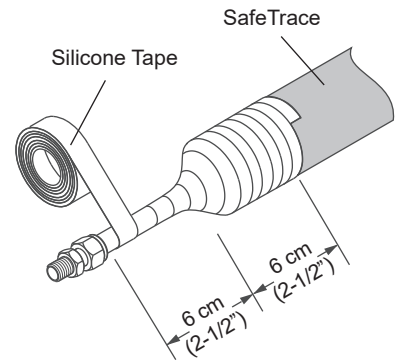
2. Deburr end of tubing making necessary field terminations.



3. Liberally apply RTV sealant to end of SafeTrace insulation.

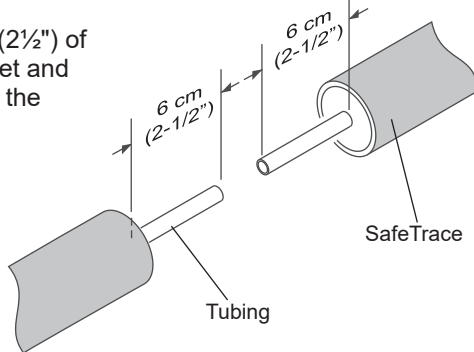


4. Wrap end of SafeTrace with silicone tape. Overlap the tape 50%, beginning 6 cm (2½") over SafeTrace insulation extending to the attachment fitting.

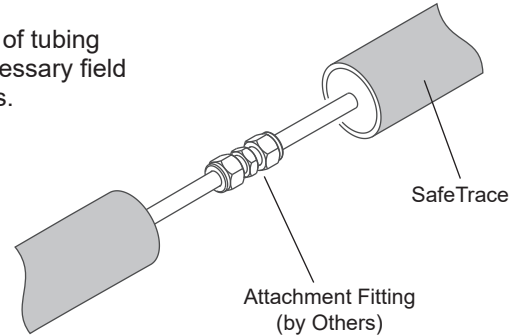


### Illustration I: FAK-8 Splice/Patch Kit Fabrication

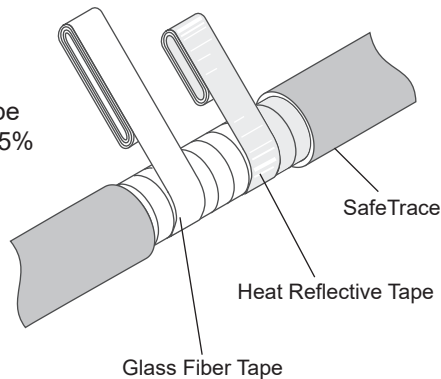
1. Remove 6 cm (2½") of the yellow jacket and insulation from the tubing.



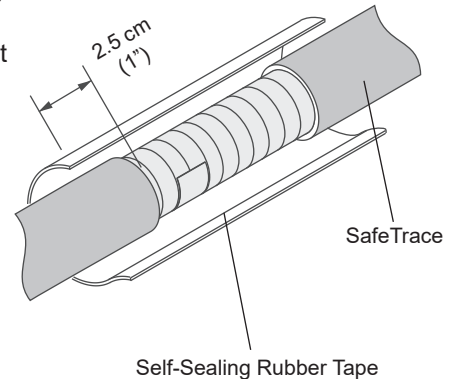
2. Deburr end of tubing making necessary field terminations.



3. Wrap glass fiber tape until level with SafeTrace insulation. Wrap heat reflective tape over fiber tape (25% overlap).



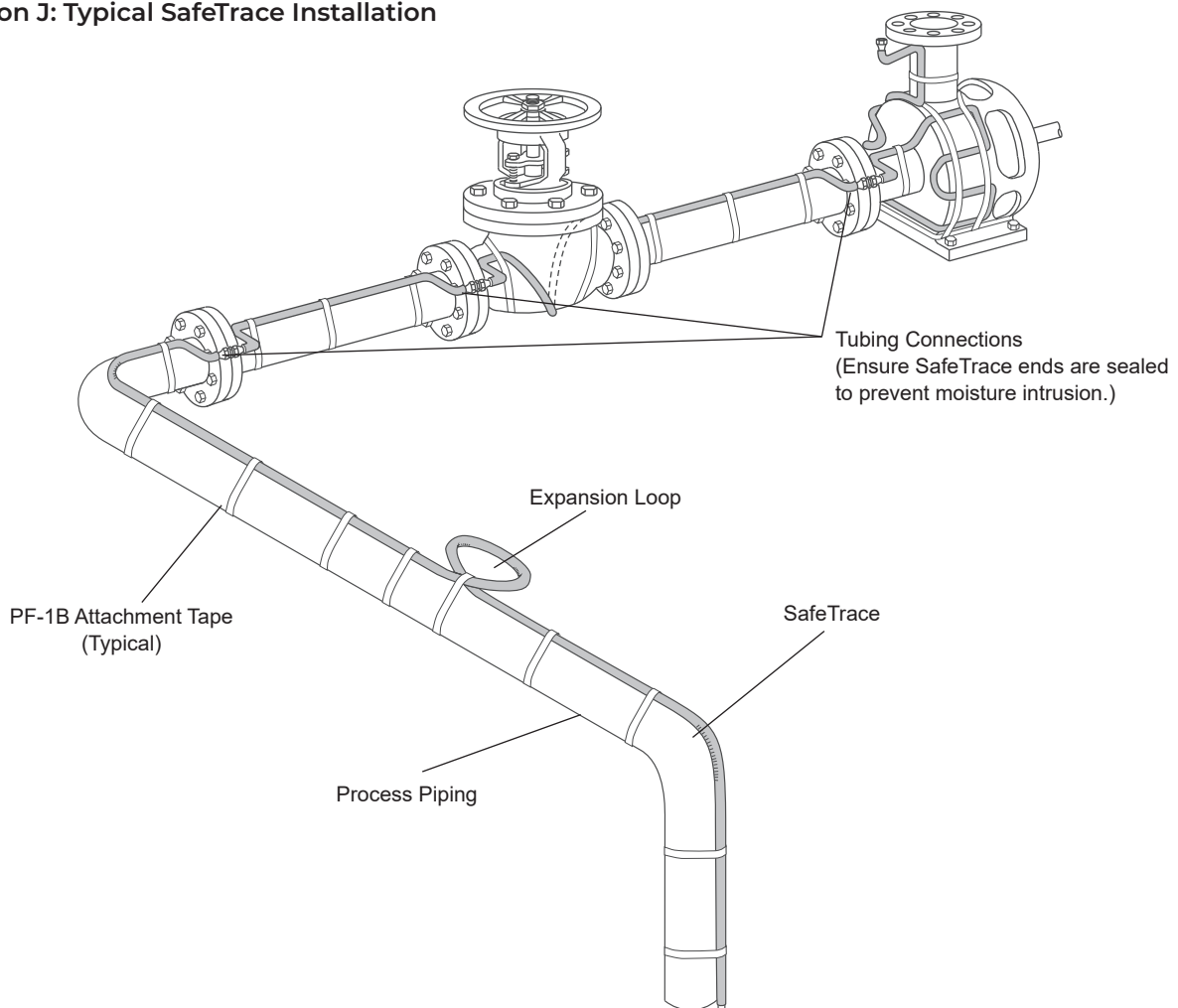
4. Wrap rubber tape around splice forming watertight seal. Allow self-sealing rubber tape to overlap SafeTrace a minimum of 2.5 cm (1") on each side of splice.



### Inspection of System

1. For ease of installation and serviceability, install SafeTrace parallel to and against the process piping. Secure the tracer to the piping on 300 mm (12 in) intervals. Space multiple tracers equally around the circumference of the pipe.
2. Thoroughly inspect SafeTrace after installation is complete to verify all bends are free of kinks and wrinkles and that flattening has not occurred. Refer to the bending guidelines on page 4 of these installation procedures.
3. To prevent stress in the tubing, provide for expansion where required. For long straight piping runs, a 300 mm (12 in) diameter expansion loop must be provided at 18 to 30 meter (60–100 ft) intervals. Tracer loops provided specifically for expansion should not contain unions.
4. Properly terminate and seal all open ends of SafeTrace using the FAK-7 end seal kit. Refer to the illustrations on page 6.
5. After all tracer connections to the supply header and trap have been completed, test the circuit for leaks by subjecting it to steam pressure equal to or greater than that which is to be used in the system or by suitable hydrostatic tests. Repair all leaks and retest the system prior to installation of the thermal insulation.
6. Refer to Illustration J for a typical installation of SafeTrace on straight run piping and around elbows, flanges, valves and pumps.

**Illustration J: Typical SafeTrace Installation**

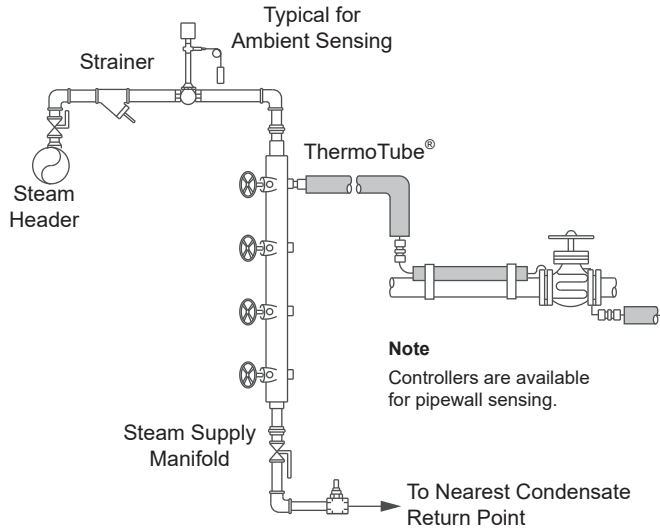




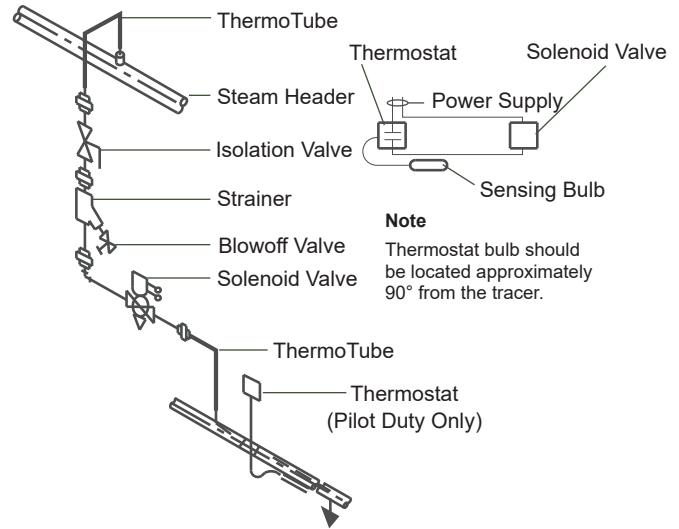
# SafeTrace™ Isolated Steam Tracers

## INSTALLATION PROCEDURES

### Illustration K: Temperature Control Details

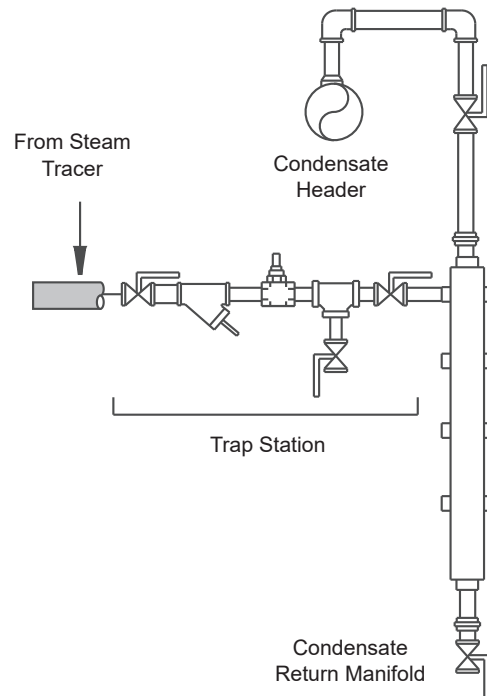
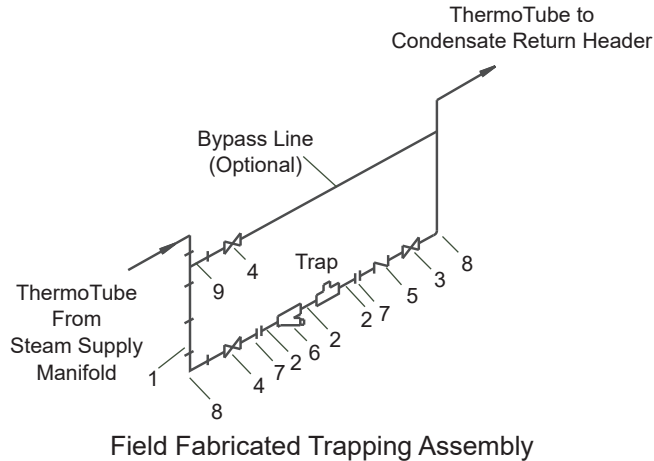


Steam Temperature Control Using Self-Actuated Mechanical Controller with Prefabricated Manifold



Steam Temperature Control Using Thermostat and Solenoid Valve for Pipe or Ambient Sensing (Field Assembly)

### Illustration L: Trapping and Condensate Handling Details



Prefabricated Trap Station and Condensate Manifold

Item No.	Description	Size
1	Pipe SMLS Schedule 80 CS PE ft	½"
2	Nipple Schedule 80 CS TBE	½" x 3"
3	Gate Valve 600 LB CS SCRD 12CR RP	½"
4	Globe Valve 600 LB CS SCRD 12CR TR	½"
5	Check Valve 600 LB CS SCRD 12CR LIFT	½"
6	Y-Strainer 600 LB CS SCRD	½"
7	Union 3000 LB CS SCRD	½"
8	Elbow 3000 LB CS SCRD	½"
9	Tee Schedule 80 CS	½"

