

**WarmTrace™ HSX™**  
Hot Water Temperature Maintenance  
**INSTALLATION PROCEDURES**



# WarmTrace™ HSX

## Safety Comes First. . .

The safety and performance of a heat tracing system depends on how the system was designed, installed and eventually maintained. Improper handling, installation or maintenance of the system could result in underheating or overheating of the water or damage to the heating cable. This damage could result in electrical shock, fire or system failure. The information, instructions, testing procedures and warnings addressed in this guide are important. To minimize these risks, read this guide prior to starting any heating cable or component installation and follow the instructions carefully.

## Approvals/Code Compliances. . .

Thermon's WarmTrace systems comprised of HSX heating cable and accessories are approved for hot water temperature maintenance by:



WarmTrace systems comply with the applicable requirements of the following code agencies:

- NEC, CEC
- Uniform Plumbing Code
- BOCA
- Southern Building Code Congress
- National Standard Plumbing Code

Be sure the electrical power connections comply with the National Electrical Code (NEC) Article 427 and any other applicable national, state or local codes.

WarmTrace systems also meet or exceed the requirements of the IEEE Recommended Practice for Testing, Design, Installation and Maintenance of Electrical Resistance Heat Tracing for Commercial Applications, ANSI/IEEE Standard 515.1

Familiarize yourself with the entire guide prior to installing any heating cable or components. Throughout this guide, the following symbols will appear to emphasize key points or an installation tip:



This symbol is intended to alert the user to the presence of important installation, operation or maintenance instruction within the guide.



This symbol identifies an installation, operation or start-up tip that could save time, installation materials or make for an improved system.

## Tools Required . . .



# INSTALLATION PROCEDURES

Refer to the “HSX Cable Testing Report” for required recording of test data and circuit information.

## Receiving, Storing, Handling . . .

1. Upon receiving heating cable, check to make sure the proper type and output have been received. All cables are printed on the outer jacket with part number, voltage rating and watt output.

Cable Type (Catalog No.)	Outer Jacket Color	Voltage (Vac)
HSX 2105-2	Blue	208
HSX 2120-2	Green	208
HSX 2140-2	Red	208

2. Visually inspect cable for any damage incurred during shipment. The heating cable should be tested to ensure electrical integrity with at least a 500 Vdc megohmmeter (megger) between the heating cable bus wires and the heating cable metallic braid. IEEE 515.1 recommends that the test voltage for polymer insulated heating cables be 2500 Vdc. Minimum resistance should be 20 megohms. (Record 1 on Cable Testing Report.)

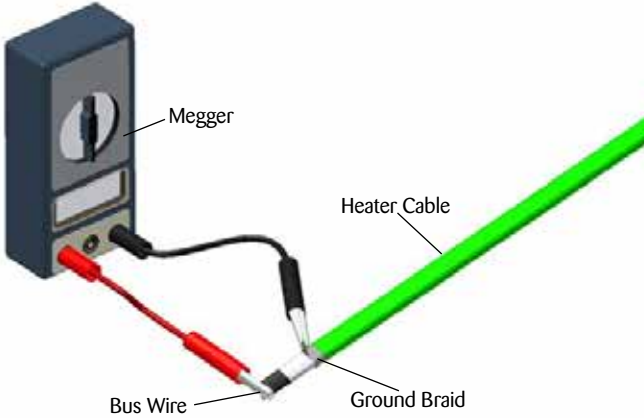

Connect the positive lead of the megger to the cable bus wires and the negative lead to the metallic braid.



**DO NOT** connect power to heating cable while it is on reel or in shipping carton.

## Typical Installation . . .

A WarmTrace HSX 2100 hot water temperature maintenance system will typically include the following components:

1. **HSX 2100** self-regulating heating cable.
2. **PCA-COM** circuit fabrication kit shown with optional Thermon supplied junction box.
3. **PCS-COM** in-line/T-splice kit (permits two or three cables to be spliced together).
4. **ET-6** cable end termination. Each PCA-COM and PCS-COM includes one ET-6.
5. **FT-1L** fixing tape secures cable to pipe; use on 12” to 24” intervals.
6. **CL** “Electric Heat Tracing” label (peel-and-stick label attaches to insulation vapor barrier on 10’ intervals or as required by code or specification).
7. Fiberglass thermal insulation and vapor barrier (by others).

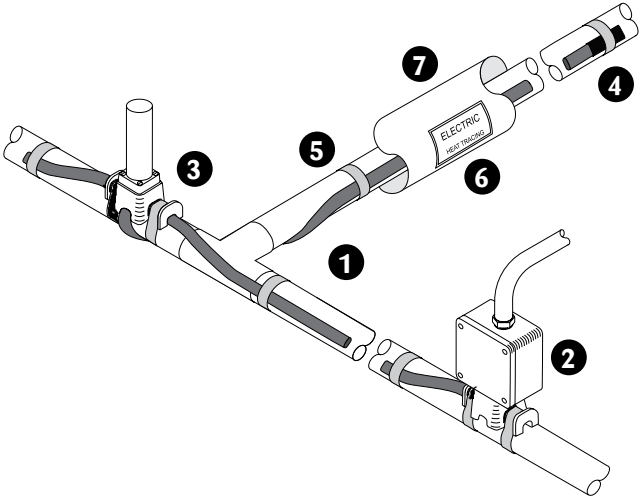

The National Electric Code and Canadian Electrical Code require ground fault protection be provided for all electric heat tracing.

3. Store cable and accessories in a clean dry place where temperatures will be between -40°C and 60°C (-40°F and 140°F).

# WarmTrace™ HSX

## Prior to Installing Cable. . .

1. Verify Electrical Resistance with a megger.
  - Refer to Cable Testing Section in this Installation Guide for details.
2. Inspect the piping to be heat traced.
  - Verify that the pipe has been pressure tested, and that all pipe supports are in place.
  - Compare layout of the installed piping vs plumbing drawings.
3. Surface areas where heat tracing is to be installed must be reasonably clean. Remove dirt, rust and scale with a wire brush and oil or grease films with a suitable solvent.
4. Plan the installation.
  - Some of the hot water supply may not require heating cable. Note the extent of heat tracing required by reviewing:
    1. Project specification
    2. Plumbing drawings
    3. Drawings supplied by Thermon (If a drawing package was part of heat trace system).
  - Allow sufficient cable to cover the longest runs first. This will insure that no additional cable or splice kits will be required.
  - The extent of heat tracing, location of power connection points, splice and end terminations can be temporarily identified with marking ribbon or spray paint.
5. Identify the heat tracing materials.
  - The cable should have been identified upon receipt. Be sure to make note that more than one water maintain temperature, and therefore more than one HSX cable, may be required for the project.
  - Familiarize yourself with the connection kits and accessory components included with the bill of materials.

## Initial Installation. . .

Begin temporary installation at the proposed end-of- circuit location and lay out heating circuit on pipe, allowing extra cable for the power connection and for any splice locations.

**Locating Power, Tee and End Termination:** Refer to the plumbing, electrical or Thermon supplied drawings to determine the locations for connections and terminations. The symbols below are routinely used to show the various components of a heat trace hot water supply system. Note that the electrical drawings will typically only show the power connection point.

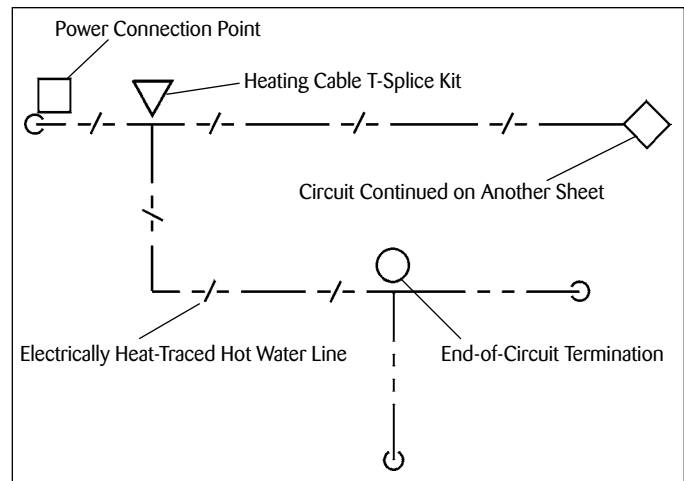

**Power Connection Points:** The power (electrical) connection points must remain accessible, even after the building is completed. If the facility will be finished out with a suspended ceiling, power connection points can be located anywhere that is convenient and accessible to electrical power. If the finished ceiling is permanent, each power connection point should be located within reach from the access door.

**Tee Splice Connections and End Terminations:** Thermon recommends that wherever possible, all connections and terminations be located in an area that allows future access should changes or additions to the plumbing system be needed.

# INSTALLATION PROCEDURES

## Installing Cable on Pipe. . .

### 1. Placement Of Cable

The HSX cable will be installed on the pipe in a parallel pass. There is no need for spiral wrapping. Locate the cable in the 10 or 2 o'clock position where possible. If accessibility is a problem the cable may be installed in the 4 or 8 o'clock position.



### 2. Attaching Cable to the Pipe

The HSX is held in place with temperature-rated attachment tape (FT-1L). Circumferential bands of tape should be installed at 300mm (12") intervals to ensure the cable maintains proper contact with the pipe.

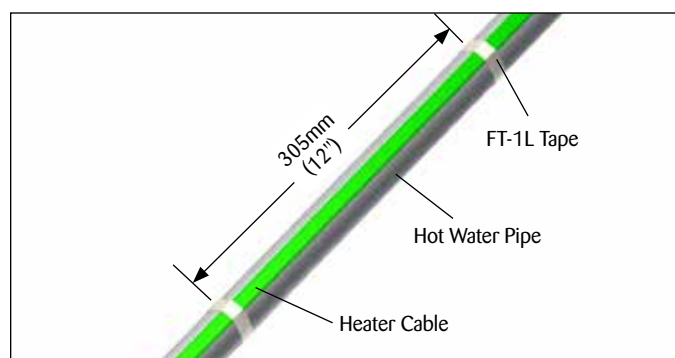

#### Attachment Tape

(Value Represents Approximate Linear Pipe Length Allowance Per Roll)

Tape Length	Pipe Diameter in Inches						
	½"-1"	1¼"	1½"	2"	3"	4"	6"
<b>33 m (36 yd)</b>	39 m (130')	35 m (115')	23 m (110')	29 m (95')	23 m (75')	20 m (65')	15 m (50')
<b>55 m (60 yd)</b>	65 m (215')	59 m (195')	55 m (180')	49 m (160')	38 m (125')	32m (105')	24 m (80')

Where space is a problem, Thermon approved plastic cable ties may be used on the same interval as tape. **Do not over tighten cable ties.**



**NO NOT** attach cable to pipe with metal hose clamps, metal strapping, tie wire or similar materials. Damaged to cable and system could result.



Avoid pinch points when installing cable. Over the course of time, the pipe will move due to vibration, thermal expansion, contraction and building settling. Do not allow the heating cable to bind between items such as pipe supports, wall or floor penetrations.

**Pipe supports:** Run the heating cable on the outside of any pipe hanger or support that comes in contact with the pipe. Thermon recommends the use of insulated pipe supports to prevent additional heat loss at the point of support.

Install Cable Like This:



Do Not Install Cable Like This:

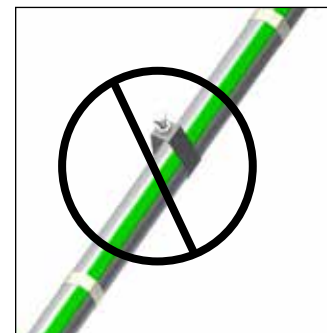

**Insulated Pipe Support:** For cork or polyurethane insulation insert, cut small hole for cable to pass through.

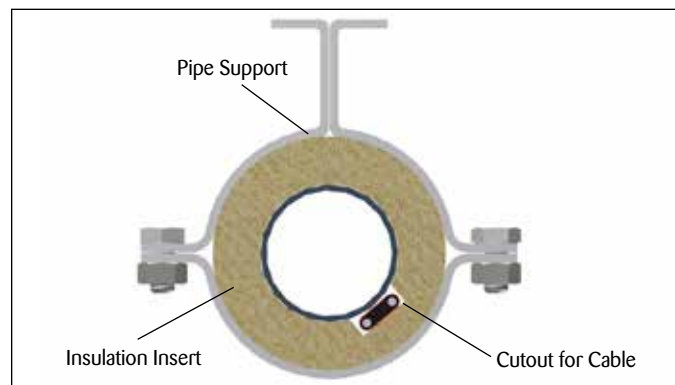

# WarmTrace™ HSX

**Wall or Floor Penetrations:** The heating cable must be protected when passing between floors or through a wall. This can be accomplished with pieces of conduit or channel. If penetration requires fire protection, the conduit or channel may be caulked with approved caulking material.

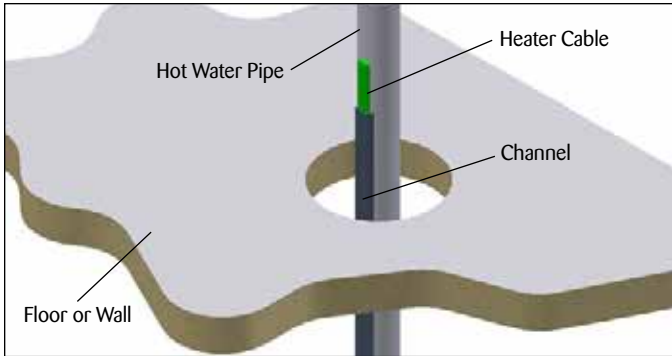

## Maximum Circuit Lengths. . .

To prevent excessive electrical currents at the branch circuit breaker supplying power to the heating cable, the maximum circuit length as shown in the chart below must be observed.

**Maximum Circuit Length vs. Circuit Breaker Size**

Catalog No.	Voltage	Breaker Size		
		15 Amp	20 Amp	30 Amp
HSX 2105-2(Blue)	208	331 m (1085')	366 m (1200')	366 m (1200')
HSX-2120-2 (Green)	208	146 m (480')	195 m (640')	293 m (960')
HSX-2140-2 (Red)	208	84 m (275')	113 m (370')	169 m (555')

### Notes:

1. These maximum circuit lengths are defined as the total length of cable that can be fed from a single power connection point, inclusive of all splices.
2. Be sure to verify the available amperage of the branch circuit breaker supplying power to the heat tracing.
3. If the power supply voltage will be different than that listed in the chart above, contact Thermon or your local Thermon representative before installing any cable.
4. Any number of shorter heat tracing circuits can be energized from a single branch circuit breaker as long as the total length of heating cable does not exceed the length stated above for a given branch circuit breaker's amperage rating.

## Completing the Installation. . .

1. Begin final cable attachment by securing the end-of-circuit termination kit and working back toward the power supply.
  - Circumferential bands of tape should be installed at 300 mm (12") intervals to keep the cable in proper contact with pipe.
  - If applicable, refer to installation details provided with the project drawings or contract Thermon for additional information regarding installation.
2. Complete splice connections (if required) in accordance with the installation instructions provided with the splice kit.
3. Install power connection kit in accordance to detailed installation instructions provided with the kit.
4. Before making power connections, repeat the megger test with at least a 500 Vdc megohmmeter (megger) between the heating cable bus wire and heating cable metallic braid. IEE 515.1 recommends that the test voltage for polymer insulated heating cable be at 2500 Vdc. The minimum acceptable level for the megger reading for any polymer insulated heat tracing cable is 20 megohms. (Record 2 on Cable Testing Report)

# INSTALLATION PROCEDURES

## Thermal Insulation . . .

1. The need for properly installed and well-maintained thermal insulation cannot be overemphasized. Without insulation, heat losses are generally too high to be offset by a conventional heat tracing system.
2. Regardless of the type or thickness of insulation used, a protective barrier should be installed. This protects the insulation from moisture intrusion, physical damage and helps ensure the proper performance of the heat tracing system. Seal around all penetrations through the thermal insulation.
3. After the installation of the thermal insulation and weather barrier but BEFORE ENERGIZING THE HEATING CIRCUIT, the megohmmeter test should be repeated. This should call attention to any damage to the heating cable that may have occurred during the insulation installation. (Record 3 on Cable Testing Report)
4. Apply caution labels to insulation weather barrier at required intervals along pipe

### Thermal Insulation with Weather Barrier

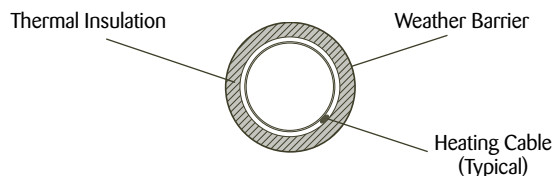

## Final Inspection and Documentation . . .

1. It is recommended that the circuit be temporarily energized so that the volts, amps, pipe temperature and ambient temperature may be recorded. This information may be of value for future reference and should be maintained for the historical operating data log (Record 4 on Cable Testing Report).
2. Once power is connected but before putting the system into operation, verify all heating cable testing and documentation have been completed for each heat tracing circuit. This will ensure that the system has been installed per the manufacturers recommendations.



Record the location of all terminations on plumbing drawings after each termination has been completed. This will ensure that no terminations are overlooked and will document the extent of the heat tracing on the drawing.

## Start-Up Procedure . . .

When a WarmTrace system has been installed per this guide, start-up is easy. Simply follow the steps listed below. Please note that the operating current for the cable will be higher during start-up than during normal operating conditions. This is because the water in the heat trace piping is usually at the building ambient temperature. This condition has been accounted for in the breaker sizing and current length table provided so long as the ambient temperature is at or above 15°C (60°F).

1. On closed loop systems a valve or faucet should be partially opened to prevent excessive pressure accumulation as temperatures rise.
2. Energize the heating cable and allow the system to reach its equilibrium temperature. The building water heater should be operating and the building's environment should be at ambient temperature 22°C-27°C (72°F-80°F).
3. The water heater/mixing valve which controls the water supply temperature should be set at the same temperature as the heating cable's nominal value i.e. 45°C (105°F), 49°C (120°F) or 60°C (140°F) Variations greater than ±5°C (10°F) could cause noticeable swings during operation.
4. Using a calibrated thermometer, check the water temperature at the water heater to be certain that it is within the desired range.
5. Again, using a calibrated thermometer, check the water temperature at various tap locations that are heat traced. Allow sufficient time for water to pass any unheated portion of water line.
6. Test for ground-fault protection by manually tripping the push-to-test button on the device (remember to reset after the test).

If start-up is not successful, refer to the Trouble Shooting section of this guide for assistance.



Disconnect power to heating cable (turn off circuit breakers) during water heater start-up and hot water system purging if water temperature will exceed 65°C (150°F).

# Troubleshooting

The following information is intended to assist in maintaining and troubleshooting a heat traced hot water system. The primary goal of a heat tracing system is to provide an efficient supply of hot water closer to the point of use than is possible with a recirculated system.

Like many other systems installed in a facility, the successful installation of a heat tracing system will require coordination among several trades involved in the construction process. Mechanical, electrical and insulation contractors must each provide services that are critical to the proper operation of the system.

Before calling your heat tracing vendor when things aren't going right, make a visual inspection; perhaps the thermal insulation is wet, damaged or missing. Also, consider the possibility that repairs or maintenance of nearby equipment may have resulted in damage to the heat tracing or its power supply. These are common causes of heat tracing problems, and they are often overlooked. A number of other possibilities are listed below, with their symptoms and remedies.

If at any time you feel that the heating cable has been damaged, a dielectric insulation resistance test with a megohmmeter (megger) is recommended.



**CAUTION**

Replace all damaged heating cable. Do not reconnect power to cable that has been exposed to excessive heat moisture. Failure to replace damaged cable can cause arcing or fire.



**CAUTION**

Disconnect power to heating cable (turn off circuit breaker) when working on heat trace pipe, or heat tracing systems.

## Symptom - Water Not Hot Enough

### Possible Causes

Water heater/mixing valve set point too low.....	Reset water heater temperature level, maximum temperature 65°C (149°F).
No power to heating cable .....	Check power distribution panel to ensure breakers are energized or have not tripped.
Splice connection missed during installation.....	Using drawing and visual inspection, check to see if any splice connection has been overlooked. This may be evident if one area of a heat traced circuit is "cold".
Compressed, missing or wet insulation .....	Replace missing or damaged insulation, ensure that pipe and insulation have not been forced against other pipes to cause heat sink along its length.
Pipes were not properly insulated .....	Ensure that insulation is per the table. Reinsulate where needed.
No heating cable installed in area.....	Verify that the pipe in question was scheduled for heating cable.
Ambient temperature too low.....	Measure ambient temperature in interstitial space where the heat traced pipe is located. If the temperature is below 22°C (71°F), the ambient is too cool. Raise the ambient temperature.
Cable not powered at correct voltage.....	Verify the proper design voltage and compare with measured value at power connection point.
Heat loss at temperature limiting valve .....	In some TLV's heat loss can occur between the hot and cold inlets via the non return valves. Check that dirt from system is not causing malfunction of the non return valves. Supply and install filter screens at inlet to valve body.

### Remedy

## Symptom - Water Too Hot

### Possible Causes

Water heater/mixing valve set point too high .....	Reset water heater temperature level, maximum temperature 65°C (149°F).
Pipes were not properly insulated .....	Ensure that insulation is per the table. Reinsulate where needed.
Ambient temperature too high .....	Measure ambient temperature in interstitial space where the heat traced pipe is located. If the temperature is above 27°C (80°F), the ambient is too high. Lower the temperature interstitial space.
Cable not powered at correct voltage.....	Verify the proper design voltage and compare with measured value at power connection point.

### Remedy

## Symptom - Circuit Breaker Tripping

### Possible Causes

Improper electrical connection.....	Cable could be damaged or improperly connected. Visually inspected heating cable, connections and terminations. Test cable with megger.
Maximum circuit length exceeded.....	Verify the length of the heating cable, including all cable located on tee splices. Compare this length with the maximum circuit length and circuit breaker sizing chart. Increase breaker size or add additional circuit if needed.
Piping/building is too cold during start-up.....	The building and the water in the pipe must be greater than 16°C (61°F). Raise building temperature or purge hot water lines.
Damaged power feed wire leading to power connection .....	Disconnect heat cable at power connection and test power feed wires running back to power distribution panel.
Faulty branch circuit breaker .....	Replace breaker and energize heating cable.

### Remedy



# INSTALLATION PROCEDURES

## Maintenance Check List. . .

As part of an annual maintenance program or after any work (repair or alteration) has been performed on or near the heat traced piping, the following steps should be performed:

1. Visually inspect the pipe's thermal insulation looking for any areas where the insulation appears repaired or replaced. Any suspect areas should be examined for damage to the heating cable. Verify that any new/repaired insulation meets the specification.
2. While inspecting the insulation, verify that it is completely dry. Wet insulation will not only cause temperature maintenance problems, but could also signal a more serious problem that could cause damage to the cable and the facility.
3. Test for ground-fault protection by manually tripping the push-to-test button on the device (remember to reset after the test).
4. Using a calibrated thermometer, check the water temperature at the water heater to be certain that it is within the desired range.
5. Again, using a calibrated thermometer, check the water temperature at various tap locations that are heat traced. Allow sufficient time for water to pass any unheated portion of water line.
6. Heating cable should be tested with a megohmmeter (megger) at the power distribution panel by a qualified electrician.
7. Record any observations on the project's as-built drawings and any maintenance log kept for facility.



Do Not enter any power connection point, cable splice or end termination while heating cable is energized. Disconnect power to heating cable and seek qualified assistance.

# WarmTrace™ HSX Cable Testing Report

1. Refer to Thermon Installation Procedures, FORM CPD 1014, for general installation procedures, requirements and guidelines.
2. Upon receiving heating cable, check the cable to make sure the proper type and output have been received. All flexible cables have the catalog number, voltage rating and watt output printed on the outer jacket.
3. Visually inspect cable for any damage incurred during shipment. The heating cable should be tested to ensure electrical integrity with at least a 500 Vdc megohmmeter (megger) between the heating cable bus wires and the heating cable metallic braid.  
IEEE 515.1 recommends that the test voltage for polymer insulated heating cables be 2500 Vdc. Minimum resistance should be 20 megohms. **(Record 1 on Cable Testing Report.)**
  - A. Connect the positive lead of the megger to the cable bus wires.
  - B. Connect the negative lead of the megger to the metallic braid.
  - C. Energize the megger and record the reading. Readings between 20 megohms and infinity are acceptable. Readings below 20 megohms may mean the electrical insulation has been damaged. Recheck the heating cable for physical damage between the braid and the heating element; small cuts or scuffmarks on the outer jacket will not affect the megger reading unless there was actual penetration through the braid and dielectric insulation jacket.
4. Once the installation is complete, but prior to installation of thermal insulation, recheck the heating cable with at least a 500 Vdc megohmmeter (megger) between the heating cable bus wires and the heating cable metallic braid. IEEE 515.1 recommends that the test voltage for polymer insulated heating cables be 2500 Vdc. Minimum resistance should be 20 megohms. **(Record 2 on Cable Testing Report.)**
5. After the thermal insulation is installed, the megohmmeter test should be repeated. Minimum resistance should be 20 megohms. **(Record 3 on Cable Testing Report.)**
6. After the thermal insulation is installed and power supply is completed, record the panel and circuit breaker information. Ensure all junction boxes, temperature controllers, cable glands, etc. are properly secured. Apply rated voltage to the heat tracing circuit(s) for 10 minutes. Record the ambient temperature, measure and record the circuit(s) voltage and current. **(Record 4 on Cable Testing Report.)**

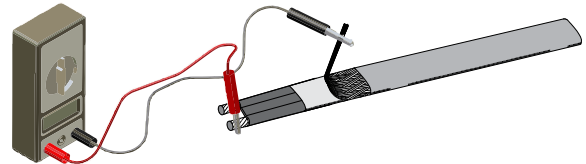

**NOTE: To ensure the heating cable warranty is maintained through installation, the testing outlined on this sheet must be completed on the installed heating cables, and the test results recorded and mailed/faxed to:**

Thermon Customer Service  
100 Thermon Drive  
San Marcos, Texas 78666  
Fax: 512-754-2420



# WarmTrace™ HSX Cable Testing Report

Customer: \_\_\_\_\_

Contractor: \_\_\_\_\_

Address: \_\_\_\_\_

Address: \_\_\_\_\_

Phone No: \_\_\_\_\_

Phone No. \_\_\_\_\_

Project Reference: \_\_\_\_\_

## Record 1: Prior to Installation

Cable Type: \_\_\_\_\_

Heater Length: \_\_\_\_\_

Heater Number: \_\_\_\_\_

Insulation Resistance M Ohms: \_\_\_\_\_

Tested By: \_\_\_\_\_

Date: \_\_\_\_\_

Witnessed By: \_\_\_\_\_

Date: \_\_\_\_\_

## Record 2: After Installation

Insulation Resistance M Ohms: \_\_\_\_\_

Tested By: \_\_\_\_\_

Date: \_\_\_\_\_

Witnessed By: \_\_\_\_\_

Date: \_\_\_\_\_

## Record 3: After Thermal Insulation is Installed

Insulation Resistance M Ohms: \_\_\_\_\_

Tested By: \_\_\_\_\_

Date: \_\_\_\_\_

Witnessed By: \_\_\_\_\_

Date: \_\_\_\_\_

## Record 4: Final Commissioning

Panel Number: \_\_\_\_\_

Breaker Number: \_\_\_\_\_

Volts: \_\_\_\_\_

Ambient Temperature (deg. F): \_\_\_\_\_

Recorded Amps: \_\_\_\_\_

Tested By: \_\_\_\_\_

Date: \_\_\_\_\_

Witnessed By: \_\_\_\_\_

Date: \_\_\_\_\_





**THERMON . . . The Heat Tracing Specialists®**

100 Thermon Dr. • PO Box 609 • San Marcos, TX 78667-0609  
Phone: 512-396-5801 • Facsimile: 512-396-3627 • **1-800-820-HEAT**  
[www.thermon.com](http://www.thermon.com) In Canada call **1-800-563-8461**