

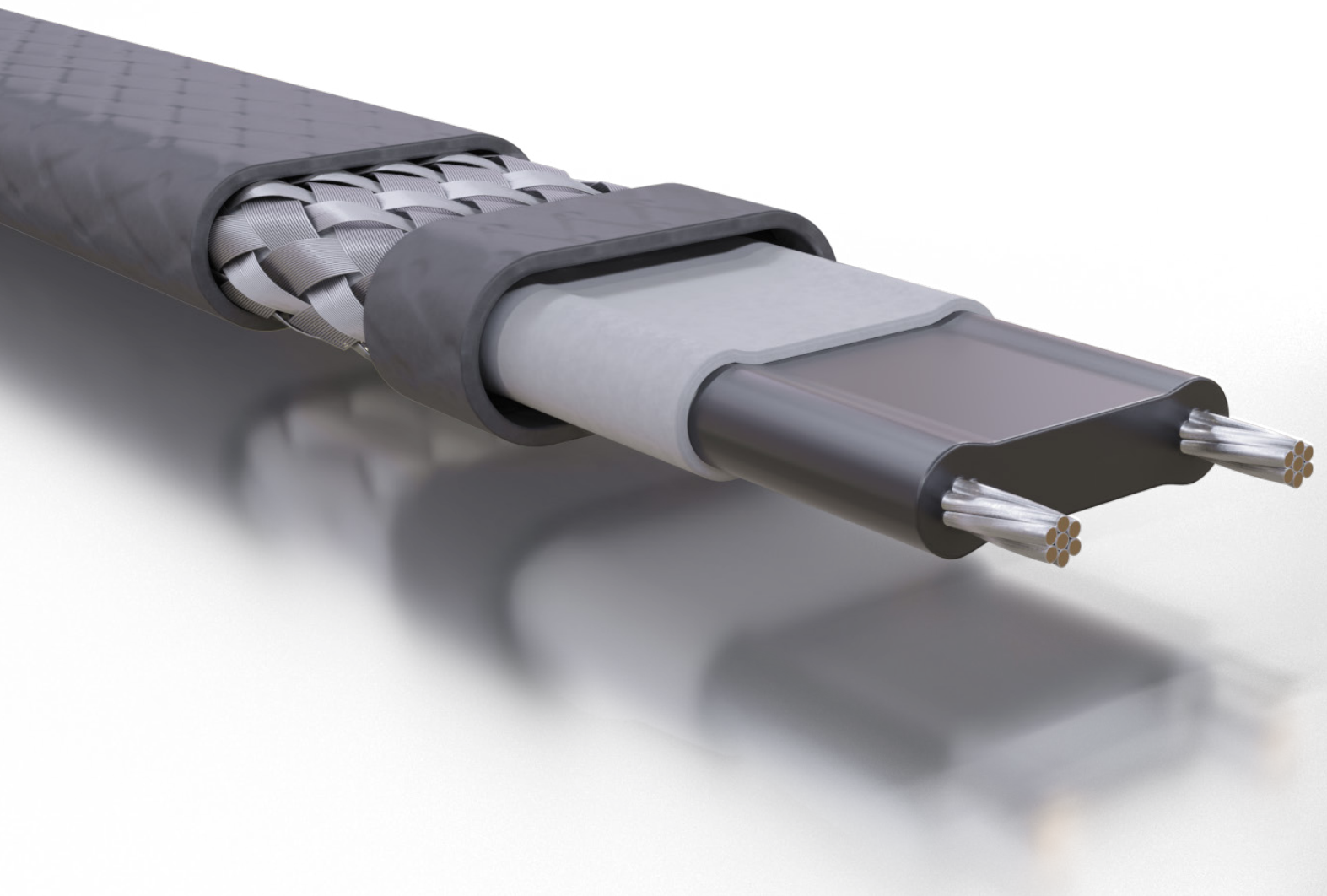

# SnoTrace™ RGS™

Systems for Roof and Gutter Snow and Ice Melting

## DESIGN GUIDE







# SnoTrace™ RGS™

Systems for Roof and Gutter Snow and Ice Melting

## DESIGN GUIDE

### Contents

Introduction .....	4
Application Information .....	4
Product Description	
Characteristics	
Approvals	
Basis for a Good Design.....	5
RGS Multipliers .....	6
Metal/Tile Roofs.....	6
Shingle Roofs.....	7
Gutters and Downspouts.....	7
Installation Accessories .....	8
Application Details .....	8
General Specification .....	10

# SnoTrace™ RGS™ Systems for Roof and Gutter Snow and Ice Melting

## Introduction

This design guide provides a basis for designing a roof and gutter snow and ice melting system. The amount of heating cable required and the performance of the system is highly dependent upon the following design parameters:

- Geographical location of project
- Orientation of building to prevailing wind and weather
- Building design and construction
- Degree of protection required<sup>1</sup>

## Product Description

RGS self-regulating heating cable varies its heat output to respond to changes in the surrounding conditions. When covered by snow or ice, the heat output of the cable automatically rises. Conversely, when exposed to dry air the cable reacts by reducing its heat output. This self-regulating feature occurs along the entire length of a heat tracing circuit to maximize snow and ice melting while conserving energy. To ensure protection during installation and for years of exposure to the elements, RGS includes a tinned copper braid for grounding plus a heavy polyolefin outer jacket containing a UV inhibitor.

For ease of installation, RGS is a cut-to-length cable requiring no detailed dimensions of the area needing protection and can be installed with ordinary hand tools. It attaches to the roof with cable roof fasteners and is routed into gutters and downspouts with cable hangers. Circuit fabrication kits designed for the application complete a SnoTrace system.

To further simplify installation, the outer jacket of each reel of RGS is printed with markers set at approximate one meter intervals. This permits easy installation of the cable directly from the shipping reel since no premeasuring and cutting of the cable is necessary. Simply keep the maximum circuit length within the allowable range indicated in Table 2.1 on page 5 of this design guide.

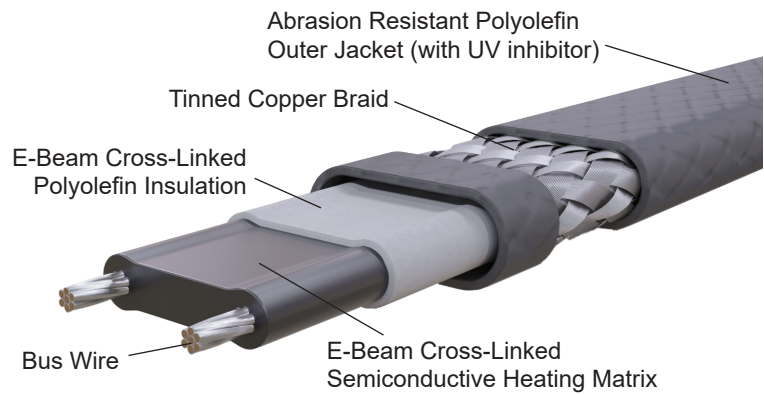

## Characteristics

Bus wire .....	1.3 mm <sup>2</sup> (16 AWG) nickel-plated copper
Heating core .....	radiation cross-linked polyolefin
Primary dielectric insulation .....	radiation cross-linked polyolefin
Metallic braid.....	tinned copper
Outer jacket .....	polyolefin (with UV inhibitor)
Minimum bend radius.....	1.25" (32 mm)
Supply voltage.....	110-120 or 208-277 Vac
Circuit protection .....	30 mA ground fault protection required
Nominal power output @ 0°C (32°F)	
In snow and ice.....	39 W/m (12 W/ft)
In dry air .....	20 W/m (6 W/ft)

### Note

1. While entire roof areas can be electrically heat traced for snow and ice removal, this design guide addresses only roof overhangs, gutters and downspouts. Should your application require more area to be protected, contact Thermon.

## RGS Cables Meet or Exceed the Following Tests

Test	Standard Followed
Abrasion Resistance	UL 1588 (8.3); IEEE 515.1 (4.3.4)
Cold Bend .....	IEEE 515.1 (4.2.10)
Deformation.....	IEEE 515.1 (4.2.8)
Dielectric Withstand .....	IEEE 515.1 (4.2.1)
Resistance to Crushing.....	UL 1588 (8.1)
Resistance to Cutting .....	IEEE 515.1 (4.3.3)
Resistance to Impact .....	UL 1588 (8.2)
Temperature .....	UL 1588 (9.1-9.3)
UV and Condensation .....	IEEE 515.1 (4.3.2)
Vertical Flame .....	UL 1588 (8.5)

## Product Approvals, Tests, and Compliances

Thermon's SnoTrace RGS carries the following major agency approvals:



Underwriters Laboratories Inc.®: RGS cables and accessories are UL Listed specifically as De-Icing and Snow Melting Equipment (KOBQ).



Canadian Standards Association

Other approvals are also in place. Contact Thermon.

In addition to the numerous tests performed by the approval agencies listed, RGS has also passed the testing guidelines outlined in IEEE Standard 515.1, *Recommended Practice for the Testing, Design, Installation, and Maintenance for Electrical Resistance Heat Tracing for Commercial Applications*.

## Basis for a Good Design

The area that will require heat tracing is based somewhat on the size and shape of the building. A building with no overhangs, for example, may only need gutter and downspout protection while an overhang covering a building entrance that is subject to drifting may need complete coverage. Typically the areas susceptible to snow and ice dams consist of:

- Roof overhangs without gutters
- Roof overhangs with gutters and downspouts
- Gutters and downspouts only

### Step 1: Identify the Area Requiring Snow and Ice Melting and Determine Level of Protection Required

Review the plans and/or design of the facility to identify the areas that will require roof and gutter snow and ice melting. To establish the level of protection necessary, decide if the climate/installation conditions fall into the moderate or heavy levels based on the following variables:

Snowfall Rate	Moderate - ≤25 mm/h (≤1"/h)	Heavy - 25-50 mm/h (1-2"/h)
Eave-to-Ridge Distance	≤6 m (≤20')	6-12 m (20-40')
Size (width) of Gutter	150 mm (≤6')	150-300 mm (6-12")

If any design variable falls into the heavy category, design the system for heavy accumulation to ensure adequate protection for the building. Should weather conditions, the building's design/orientation or the expected usage of the facility dictate, increase the amount of cable to be installed.

### Step 2: Select Proper RGS Cable Based on:

**Operating Voltage** RGS self-regulating cables are available in two voltage groups: 110-120 Vac and 208-277 Vac. Determine what voltage is available for use with heat tracing.

**Branch Circuit Breakers** Use Table 2.1, Cable Selection, to match the RGS circuit length with the available branch circuit breaker size. If a known branch circuit breaker size is being used, match this value with the corresponding RGS circuit length. If breaker size will be dictated by heating cable requirements, determine the optimal RGS circuit lengths based on the project size and cable layout.

**Expected Circuit Lengths** The maximum circuit lengths shown in Table 2.1 are based on RGS cable start-up at the ambient temperatures shown. Because the power output of RGS will vary to meet the needs of the surrounding environment, the operating load will vary.



**The National Electrical Code and Canadian Electrical Code require ground-fault protection be provided for electric heat tracing.**

### Step 3: Specify Locations for Power Connections; Lay Out Cable

1. The UL Listed junction boxes (by others) used for connecting the heating cable to power should, whenever possible, be located under a roof overhang or similar area to avoid direct exposure. Provide drip loops where the power feed and heating cable enter the junction box.
2. On larger projects with multiple circuits or where the design layout permits, locate the power connection points for two circuits in the same location to reduce power feed conduits.
3. To aid in design, RGS multipliers are given for the most common roofing material types. Use these multipliers, shown in Tables 3.1 through 3.3, to determine the footage of RGS cable required based on the variables indicated. Be sure to add sufficient extra cable to get from the heat traced area back to the power connection point.

### Step 4: Choose RGS Installation Accessories

An RGS roof and gutter system will typically use the installation accessories detailed on page 8. As a minimum, the heating cable must be terminated with an RGS-CFK circuit fabrication kit to properly terminate the ends of the cable.

### Step 5: Establish Control Method Needed to Operate System

All roof and gutter snow and ice melting systems should be controlled to turn the heating cable on and off as conditions warrant. There are three basic means to activate a roof and gutter system:

1. Manual On/Off Switch—Economical and simple to install; requires diligence on the part of the operator.
2. Ambient Sensing Control—Turns system on and off based on ambient temperature. Heating cable will frequently be energized during non-required times.
3. Automatic Control—Roof or gutter-mounted ice sensor turns system on when moisture is detected and temperatures are in the range when freezing can occur on roof overhangs or in gutters.

**Table 2.1 Cable Selection**

Catalog Number	Start-Up Temperature	Operating Voltage	Maximum Circuit Length vs. Breaker Size			
			15 A	20 A	30 A	40 A
RGS-1	-18°C (0°F)	120 Vac	24 m (80')	32 m (105')	47 m (155')	53 m (175')
RGS-1	-7°C (20°F)	120 Vac	30 m (100')	41 m (135')	53 m (175')	53 m (175')
RGS-2	-18°C (0°F)	208 Vac	44 m (145')	58 m (190')	88 m (290')	107 m (350')
RGS-2	-7°C (20°F)	208 Vac	56 m (185')	74 m (245')	107 m (350')	107 m (350')
RGS-2	-18°C (0°F)	240 Vac	45 m (150')	61 m (200')	90 m (295')	107 m (350')
RGS-2	-7°C (20°F)	240 Vac	58 m (190')	76 m (250')	107 m (350')	107 m (350')
RGS-2	-18°C (0°F)	277 Vac	47 m (155')	62 m (205')	95 m (310')	107 m (350')
RGS-2	-7°C (20°F)	277 Vac	59 m (195')	78 m (255')	107 m (350')	107 m (350')

# SnoTrace™ RGS™ Systems for Roof and Gutter Snow and Ice Melting

## RGS Multipliers

Select a multiplier from the examples shown based on the type of roofing material utilized. If gutters and downspouts will also require protection, be sure to add the cable requirements (see Table 3.3) to the roof overhang footages.



**Attention: Where conditions dictate (heavy snow loads, steep roof slopes, smooth roofing materials or long eave-to-ridge distances), snow fences and/or snow brakes should be considered to prevent/reduce the potential for damage to the cable and/or facility.**

How far up the roof the heating cable should travel may be determined by measuring the distance as shown at right. The heating cable should loop past the point where an imaginary line extending up from the inside wall would pass through the roof.

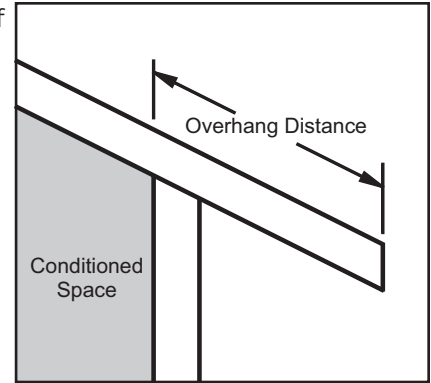

## Metal/Tile Roofs

Metal roofing materials such as standing seam or corrugated, as well as tile/concrete roofing materials that have distinct ridges or grooves, must be properly addressed when installing heat tracing. Metal roofs in particular pose an avalanche potential that could damage the heating cable if it were installed in a serpentine pattern. To combat this, the cable is installed parallel to the standing seams or along the length of a corrugation. The partial sketch below depicts RGS cable as it would be installed on a corrugated metal roof. This method would also be used on standing seam or tile roofs.

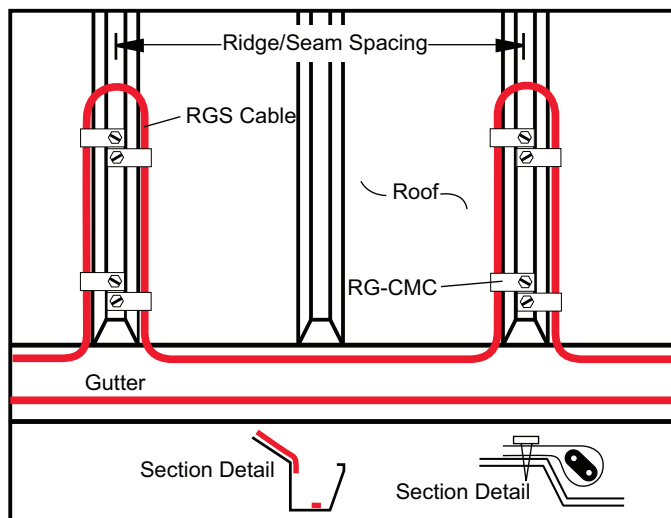

Any number of attachment methods may be used for holding the heating cable in place. Whichever method is used should take into consideration the integrity of the roof and the heating cable.

To determine the layout pattern for RGS heating cable on metal or tile roofs, use Table 3.1 in conjunction with measurements of the spacing of the seams, corrugations or ridges in the roofing material. This spacing, combined with the desired level of protection, will determine what multiplier to use to determine the footage of cable required. (Heating cable does not have to be installed on every seam, corrugation, etc.) Be sure to add sufficient extra cable to reach the power connection point for each circuit.

**Table 3.1 Metal/Tile Roofs**

Overhang Distance	Ridge/Seam Spacing							
	250 mm (10")	300 mm (12")	350 mm (14")	400 mm (16")	450 mm (18")	500 mm (20")	550 mm (22")	600 mm (24")
300 mm (12")	4.2	3.7	3.3	3.0	2.8	2.6	2.5	2.4
450 mm (18")	5.4	4.7	4.2	3.8	3.5	3.2	3.0	2.9
600 mm (24")	6.6	5.7	5.0	4.5	4.1	3.8	3.6	3.4
750 mm (30")	7.8	6.7	5.9	5.3	4.8	4.4	4.1	3.9
900 mm (36")	9.0	7.7	6.7	6.0	5.5	5.0	4.7	4.4

Heavy Conditions Multipliers
  Moderate Conditions Multipliers

To establish the amount of cable required, select the overhang distance that fits the application and follow this row across to the ridge/seam spacing column that corresponds to the roofing material. The number where the row and column intersect is the multiplier for that application. Multiply this number by the number of linear meters (feet) of roof eaves to be protected and add sufficient cable to reach the power supply junction box plus any additional cable to allow for on-site variations.



## Shingle Roofs

All shingle roofs (fiberglass, cedar shake, flat tile or concrete shingle) can utilize heating cable installed in a serpentine pattern as detailed in the partial sketch below. The heating cable may be attached to the roof and fascia with cable fasteners (Catalog No.

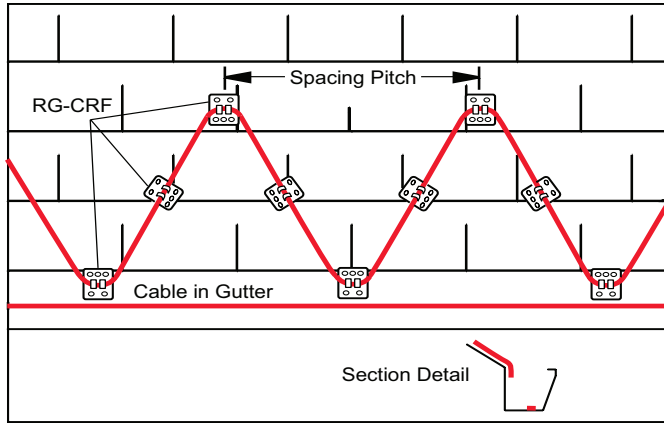

RG-CRF) or similar devices held in place with suitable fasteners or adhesives. Typically one RG-CRF per peak and one in each lineal run of cable greater than 0.6 m (24"). Care should be exercised to maintain the integrity of the roof.

To determine the layout pattern for RGS heating cable on shingle-style roofs, use Table 3.2. Recommended moderate and heavy conditions

multipliers have been shaded for each overhang distance. Should conditions dictate a specific pitch, multipliers for additional spacings have been included. Be sure to add sufficient extra cable to reach the power connection point for each circuit. To establish the amount of cable required, select the

**Table 3.2 Shingle Roofs**

Overhang Distance	Spacing Pitch							
	350 mm (14")	400 mm (16")	450 mm (18")	500 mm (20")	550 mm (22")	600 mm (24")	650 mm (26")	700 mm (28")
450 mm (18")	3.3	3.0	2.7	2.4	2.3	2.1	NR	NR
600 mm (24")	4.2	3.7	3.3	3.0	2.8	2.6	2.4	2.3
750 mm (30")	5.0	4.4	3.9	3.6	3.3	3.0	2.8	2.7
900 mm (36")	5.8	5.1	4.6	4.1	3.8	3.5	3.3	3.1
1050 mm (42")	6.7	5.9	5.2	4.7	4.3	4.0	3.7	3.5

Heavy Conditions Multipliers
  Moderate Conditions Multipliers

row with the corresponding overhang distance and follow across to the multiplier that matches the level of protection desired. After selecting a multiplier, read the corresponding spacing pitch value at the top of the column. Multiply this number by the number of linear feet of roof eave to be protected and add sufficient cable to reach the power supply junction box.

## Gutters and Downspouts

RGS heating cable can be utilized in gutters and downspouts regardless of whether heating cable has been installed on the roof. The amount of cable required is based on the width of the gutters, the level of protection desired and the linear footage of gutters and downspouts. A typical layout is shown below.

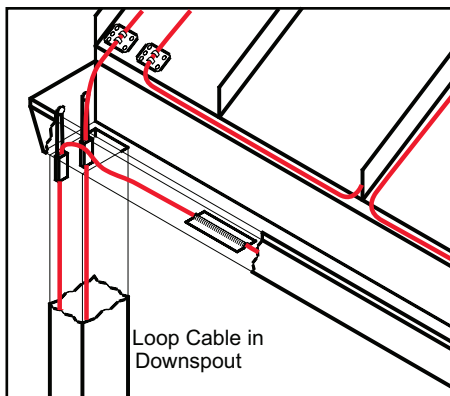

As stated in IEEE Standard 515.1, *Recommended Practice for the Testing, Design, Installation, and Maintenance for Electrical Resistance Heat Tracing for Commercial Applications*, in-line and T-splice kits should be avoided. This will require that heating

cable in downspouts be looped (also an IEEE 515.1 recommendation) to eliminate splicing the cable. Additionally, the heating cable end termination should not be located in the lowest portion of the downspout.

Select the level of protection required (based on the size of the gutter) from Table 3.3. Choose the multiplier which corresponds to the application and apply this multiplier to the footage of gutters and the number and footage of downspouts to be heat traced. Add sufficient heating cable (including a drip loop) to reach the power connection junction box.

**Table 3.3 Gutters and Downspouts**

Gutter Width	Gutter Allowance	Downspout Allowance
≤150 mm (≤6")	1X Gutter Length	1X Downspout Length
150-300 mm (6-12")	2X Gutter Length	2X Downspout Length
≥300 mm (≥12")	Contact a Thermon Factory Representative	

# SnoTrace™ RGS™ Systems for Roof and Gutter Snow and Ice Melting

## Installation Accessories

1. **18-SXG-KIT** power connection kit and **ET-4S** heat shrink end termination kit are used (junction box supplied separately).
2. **CL-1** "Electric Heat Tracing" labels peel and stick to junction boxes, breaker panels and control panel(s), or as required by code or specification.
3. **RG-CMC** cable mounting clips secure RGS heating cable to the roof utilizing screws and a waterproof cover material.
4. **RG-CRF** cable roof fasteners attach RGS heating cable to roof or fascia materials. Can be secured with fasteners or adhesives compatible with roofing material.
5. **RG-DCH** downspout cable hanger secures heating cable at downspouts to remove strain at lip of downspout/gutter contact point.
6. **AL-20L** aluminum tape secures heating cable to bottom of clean gutter to keep cable in place during rain.

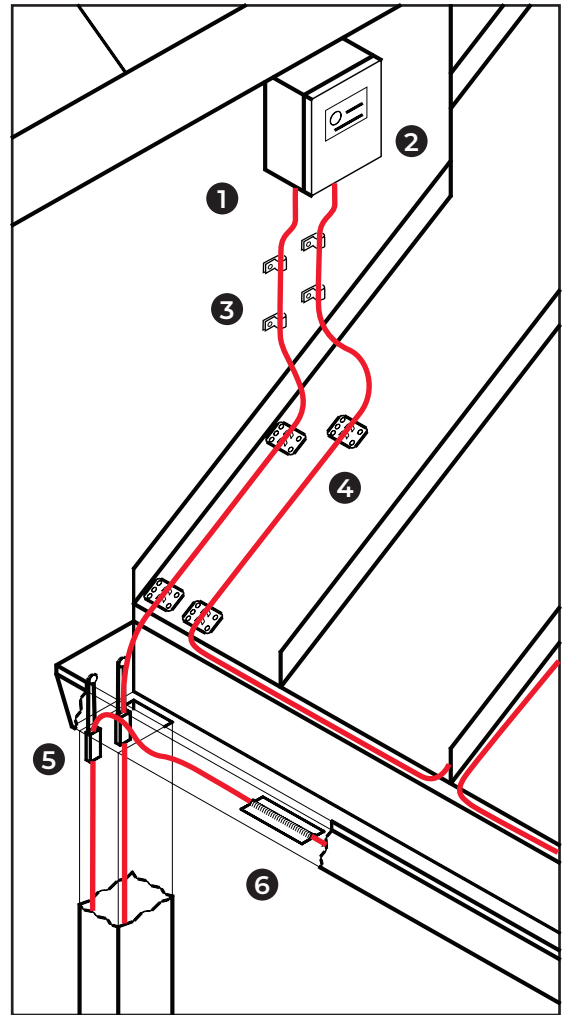

## Application Details

### 7. Roof Drains

Roof drains may require heat tracing to prevent blockage due to ice buildup. Heating cable should extend a minimum of 300 mm (12") into the heated portion of the building. If building is unheated, extend heat tracing down to the storm sewer (see 8. at right).

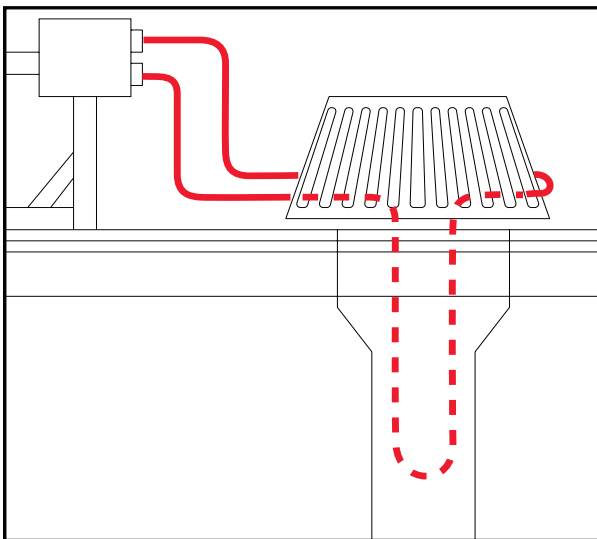

### 8. Downspouts to Underground Storm Sewers

When downspouts are routed to storm sewers located below the frost line, extend the RGS cable down to the point where the vertical drain meets the horizontal drain. The cable should not extend into the horizontal drain line.

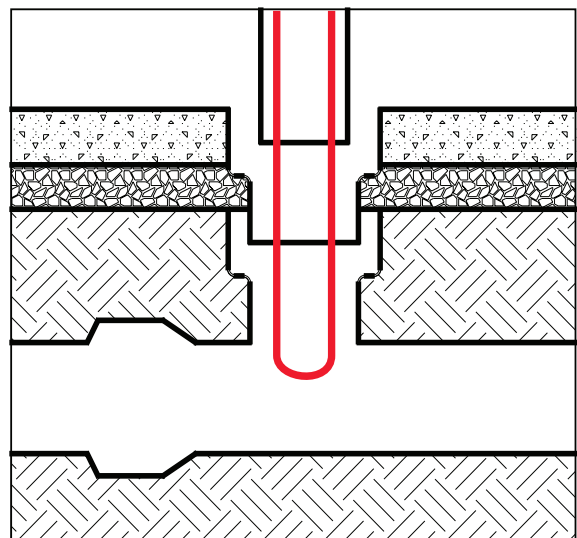



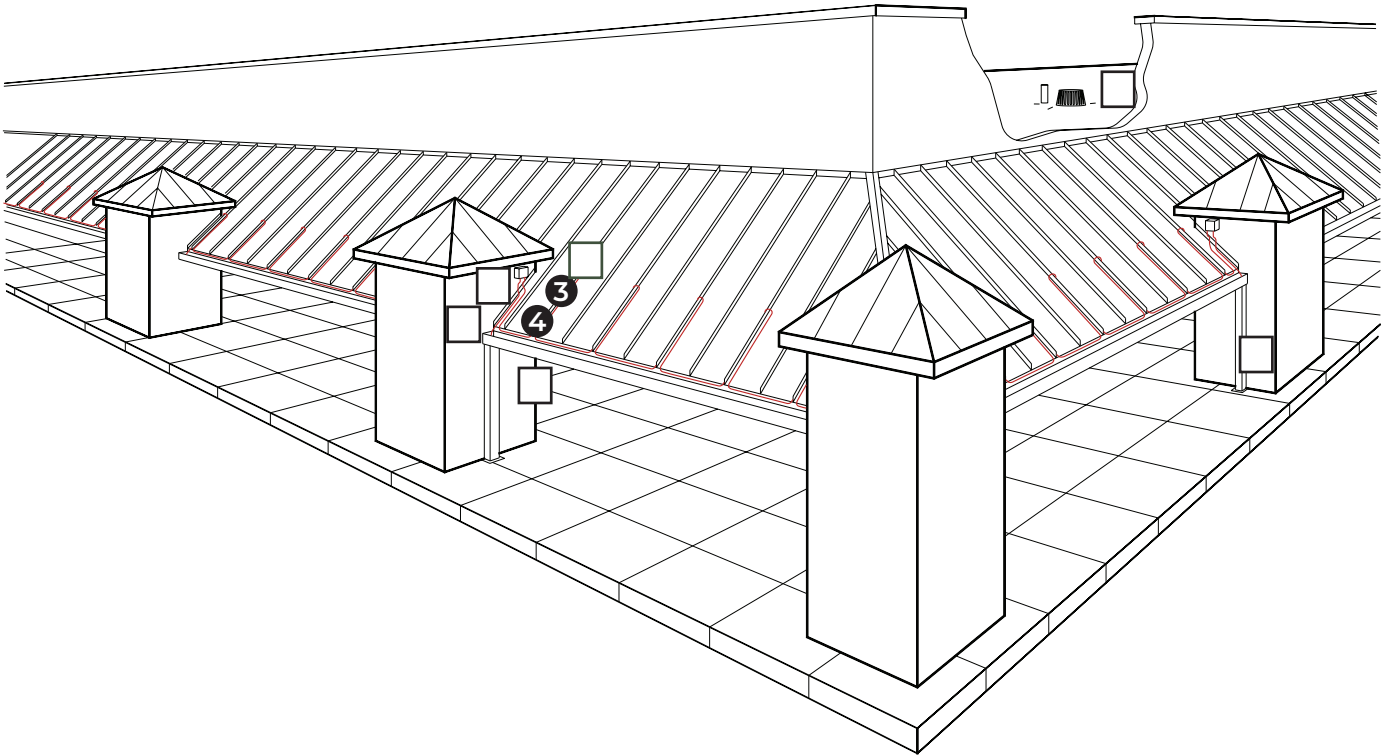

**Example**

To determine the recommended amount of cable for a standing seam metal roof under a heavy snowfall rate with 350 mm seams/ridges and a 450 mm overhang use Table 3.1 on page 6.

Using the column for 350 mm seams/ridges and the row for an 450 mm overhang indicates the application would require 4.2 m of cable per linear meter of roof. Therefore if the length of the roof was 30 x 4.2 = 126 meters of cable for the roof surface (additional cable required for power connection, see complete calculations below).

Continuing with the example, refer to Table 3.3 on page 7 to determine the amount of cable required for a 300 mm gutter with 3 downspouts that are 4.5 m in length.

Using the row for 150-300 mm gutter widths indicates that a 2x multiplier should be used for the total gutter length and downspout length. Therefore the total length of roof 30 x 2 = 60 meters for the gutters. Additionally, each 4.5 m downspout would require 4.5 x 2 = 9 meters of cable. Multiply this total times three downspouts: 9 x 3 = 27 meters for the three downspouts.

As the example will have 240 Vac, single phase power available, RGS-2 is selected. To optimize the circuit length potential, two 30 A circuits will be utilized. Be sure to add sufficient extra cable to reach the power connection point for each circuit. In this example 0.6 meter per circuit is sufficient.

Roof length.....	30 x 4.2 =	126
Gutter length .....	30 x 2 =	60
3 Downspouts.....	3 x (4.5 x 2) =	27
2 Power connections.....	2 x 0.6 =	1.2
		214.2

# SnoTrace™ RGS™ Systems for Roof and Gutter Snow and Ice Melting

## General Specification

### Part 1 General

Furnish and install a complete UL Listed system of heaters and components approved specifically for snow and ice melting of roofs, gutters and downspouts. The heat tracing system shall conform to ANSI/IEEE Standard 515 and IEEE Standard 515.1.

### Part 2 Products

1. The heating cable shall be of parallel resistance construction capable of being cut to length and terminated in the field. Series resistance cables will not be allowed.
2. The self-regulating heater shall consist of two 1.3 mm<sup>2</sup> (16 AWG) nickel-plated copper bus wires embedded in parallel in a radiation cross-linked self-regulating conductive polymer core specifically designed for snow and ice melting. The heater shall be capable of varying its heat output along its entire length. Power output of the heater shall be 39 W/m @ 0°C (12 W/ft @ 32°F) when surrounded by snow or ice and 20 W/m @ 0°C (6 W/ft @ 32°F) when exposed to dry air. The heater shall be covered by a polyolefin dielectric jacket, a tinned copper braid, and a UV stabilized polyolefin outer jacket.
3. The heater shall operate on a line voltage of (select: 110-120 or 208-277) Vac without the use of transformers.
4. Power connections shall be made in UL Listed junction boxes (by others) as described under Part 6, Installation.
5. All heating cable core will be permanently marked with the manufacturer's identification number for traceability.
6. Acceptable products and manufacturers are SnoTrace™ RGS™ as manufactured by Thermon.
7. Refer to the manufacturer's "Roof and Gutter Snow and Ice Melting Design Guide" for design details, maximum circuit lengths and accessory information.

### Part 3 Power Distribution and Control

1. Circuit breakers supplying power to the heat tracing must be equipped with 30 mA minimum ground fault equipment protection.
2. Systems with four or more circuits shall utilize a dedicated power distribution and contactor panel provided by the roof and gutter snow and ice melting system manufacturer. Included in each panel will be a main breaker, contactor and 30 mA ground fault branch circuit breakers. The panel enclosure will be rated for NEMA (select: 12 for indoors or 4 for outdoors) service. All panel components shall be UL Listed and/or CSA certified.
3. Power to the roof and gutter snow and ice melting circuits will be controlled by (select: a manual switch, an ambient sensing thermostat or an automatic snow/ice sensor) designed to control the heating cable load or the coil of a contactor.

### Part 4 System Performance

1. Amount of cable required to maintain a clear path for melted snow and ice to drain shall be based on size and shape of protected area and expected weather conditions.
2. Design and layout must comply with Section 6.2, Roof and Gutter De-Icing, of the IEEE Standard 515.1, *Recommended Practice for the Testing, Design, Installation, and Maintenance fo Electrical Resistance Heat Tracing for Commercial Applications*.
3. Power retention of the heating element shall be in accordance with IEEE Standard 515.1, Item 4.2.6, Performance After Thermal Aging.

### Part 5 Manufacturer

1. The manufacturer shall demonstrate experience designing snow and ice melting systems. This experience may be documented with a list of \_\_\_\_\_ engineered projects with a minimum of 150 m (500 ft) of heating cable.
2. Manufacturer's Quality Assurance Program shall be certified to the ISO 9001 Standard.

### Part 6 Installation

1. Heating cable shall be installed directly on the roof or in gutters or downspouts per manufacturer's installation guide. Attachment shall be made with roof clips, downspout cable hangers and/or aluminum tape as required to secure cable. All attachments should be made to maintain the integrity of the roof by use of sealants or adhesives compatible with the roofing materials.
2. Power connections shall be located in NEMA 4 or 4X junction boxes (by others).
3. All installations and terminations must comply with all applicable regulations outlined in the NEC and CEC, and any other applicable national and local electrical codes.
4. Circuit breakers supplying power to the heat tracing must be equipped with 30 mA minimum ground fault equipment protection.

### Part 7 Testing

1. Heating cable shall be tested with a 2,500 Vdc megohmmeter (megger) between the heating cable bus wires and the heating cable metallic braid. While a 2,500 Vdc megger test is recommended, the minimum acceptable level for testing is 1,000 Vdc. This test should be performed a minimum of two times:
  - a. Prior to installation while the cable is still on reel(s).
  - b. After installation of heating cable and completion of circuit fabrication kits but prior to connection to power.
2. The minimum acceptable level for the megger readings is 20 megohms regardless of the circuit length.
3. Results of the megger readings should be recorded and submitted to the construction manager.





Corporate Headquarters: 7171 Southwest Parkway · Building 300, Suite 200 · Austin, TX 78735 · Phone: 512-690-0600  
For the Thermon office nearest you visit us at . . . [www.thermon.com](http://www.thermon.com)

**Form CPD1037C-0222**

© Thermon, Inc. · Printed in U.S.A. · Information subject to change.