

Terminator DS/DE FAK-4LHT

In-Line Splice Kit for
Electrically Heated
TubeTrace® Bundles

INSTALLATION PROCEDURES



Terminator DS/DE FAK-4LHT

Receiving, Storing and Handling

1. Inspect materials for damage incurred during shipping.
2. Report damages to the carrier for settlement.
3. Identify parts against the packing list to ensure the proper type and quantity has been received.
4. Store in a dry location.

Terminator DS/DE FAK-4LHT Kit Contents



Item	Quantity	Description
1	1	Expediter Assembly: Flat Mount Base, Grommet, Threaded Grommet Compressor, and Support Cap with O-Ring
2	1	Splice Cap
3	1	In-Line Splice Cover (Top)
4	1	In-Line Splice Cover (Base)
5	1	Nut
6	1	Heat Reflective Tape
7	3	RTV Sealant Tube
8	1	Glass Fiber Tape
9	1	Silicone Gasket
10	1	Self-Vulcanizing Tape
11	1	Heavy Foil Tape, 44.5 mm (1.75") wide
12	1	Fiberglass Rope, 13 mm x 366 cm (1/2"x 12')

Required: Order Separately for each heater to be fabricated.

SCTK Power and End Termination Kits (one req'd. per heater)

SCTK-3D for HPT

Dimensions

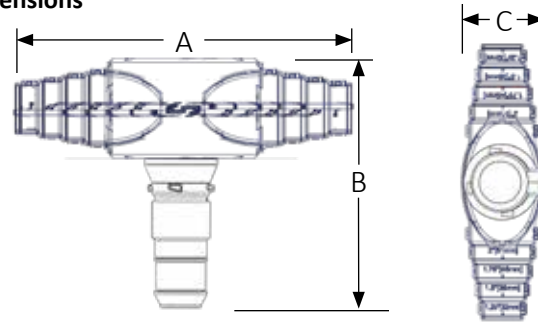

	A mm (inch)	B mm (inch)	C mm (inch)
Terminator DS/ DE FAK-4LHT	489 mm (19-1/4")	321 mm (12-5/8")	141 mm (5-1/2")

Installation Precautions

- To minimize the potential for arcing on electrical heat tracing and fire caused by product damage or improper installation, use ground-fault protection. The National Electrical Code (NEC) and Canadian Electrical Code (CEC) require ground-fault protection of equipment for each branch circuit supplying electrical heat tracing.
- Installation must comply with Thermon requirements and be installed in accordance with the NEC, CEC, or any other applicable national and local codes.
- Component approvals and performance ratings are based on the use of Thermon specified parts only. User supplied power connection fittings must be listed or certified for intended use.
- De-energize all power sources before opening enclosure.
- Keep ends of heating cable and kit components dry before and during installation.
- Individuals installing these products are responsible for complying with all applicable safety and health guidelines. Proper personal protective equipment, or PPE, should be utilized during installation. Contact Thermon if you have any additional questions.

Terminator DS/DE Certifications/Approvals



IP66 NEMA/Type 4X -60°C ≤ Ta ≤ +55°C
 Ordinary & Hazardous Locations
 Class I, Division 2, Groups A, B, C, & D, Zone 2 IIC
 Class II, Division 2, Groups F & G,
 Class III Listed Heat Tracing System 137M



Tools Required



INSTALLATION PROCEDURES

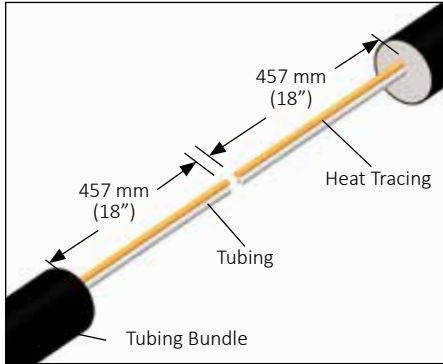

1. Remove outer jacket and insulation from tubing bundle approximately 457 mm (18") from end of the tubing bundle.



Do not cut or damage the heat trace or sampling tube.
CAUTION (Found on TubeTrace SE/ME bundles)

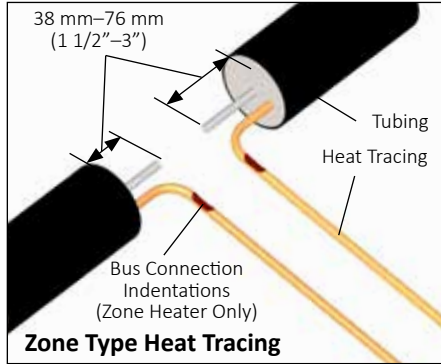

2. Strip back bundle insulation 38 mm (1-1/2") to 76 mm (3") beyond bus connection indentation of each heat tracing. If bus connection indentation is less than 305 mm (12")-381 mm (15") from end of the heat tracing, proceed stripping the bundle insulation to the next indentation. Trim tubes so the bus connection indentation on each meet.

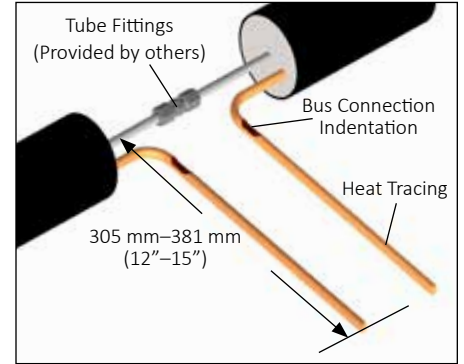

3. Make tube connections with appropriate fittings, provided by others. Test fittings for leaks before proceeding.

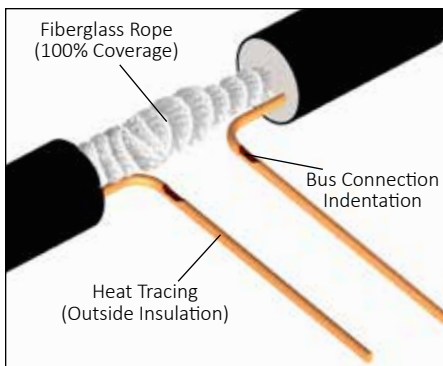

4. Wrap high temperature tubing with 1/2" fiberglass rope. Ensure 100% coverage to keep tubing and heat tracing from making contact. **DO NOT wrap heat trace with fiberglass rope.**

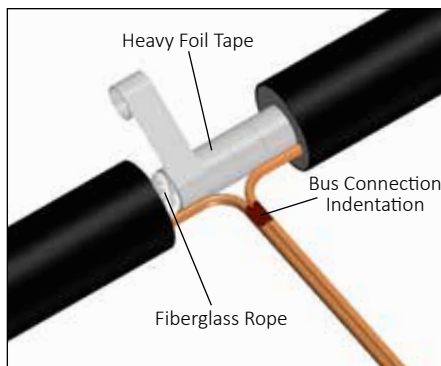

5. Wrap rope with one pass of heavy foil tape (25% overlap).

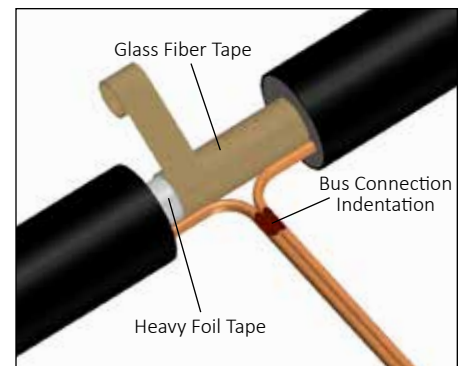

6. Wrap with 3 passes of glass fiber tape (50% overlap).

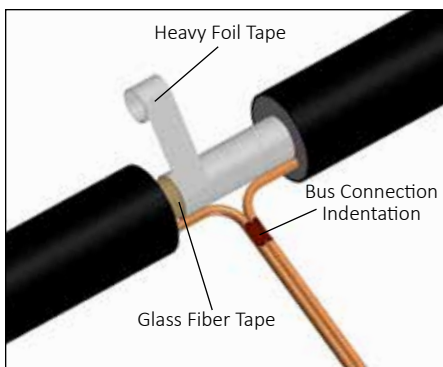

7. Add 1 additional pass of heavy foil tape (25% overlap).

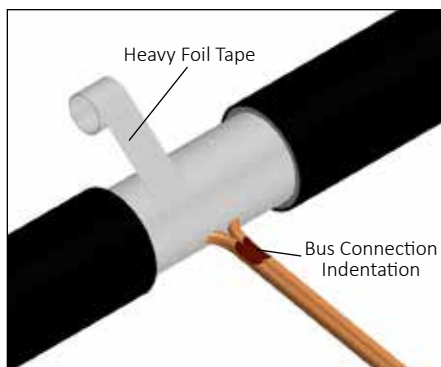

8. Complete with 1 additional pass of heavy foil tape (25% overlap) to cover heat trace.

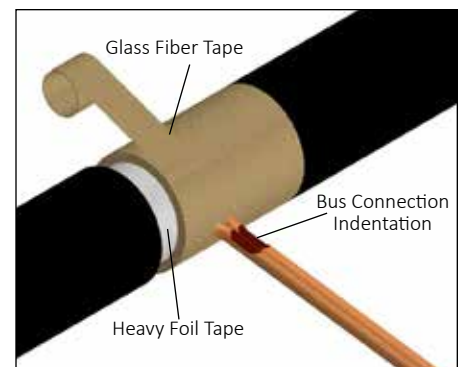

9. Wrap with 4 passes of glass fiber tape (50% overlap), or until fiber tape is equal to original bundle insulation thickness.

Terminator DS/DE FAK-4LHT

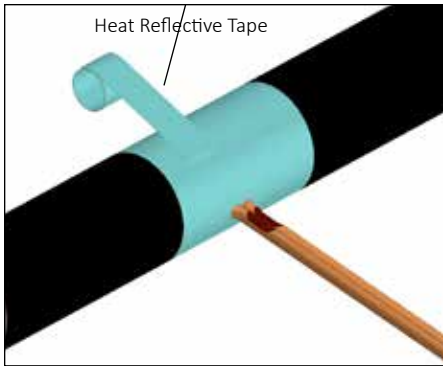

10. Wrap with 1 additional pass of heat reflective tape (50% overlap).

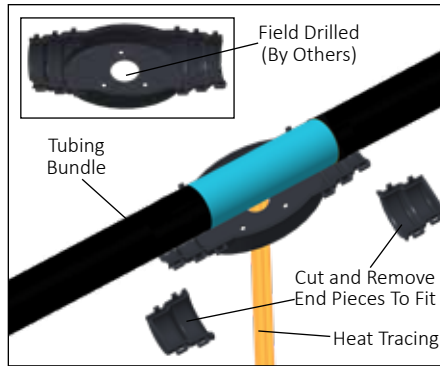

11. Cut splice cover ends to match outside diameter of tubing bundle. Field drill expediter base holes.

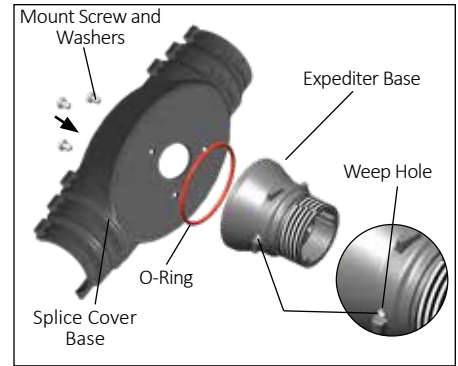

12. Mount expediter base with o-ring to the splice cover base using (3) M5 mounting screws and lock washers. Punch out weep hole.

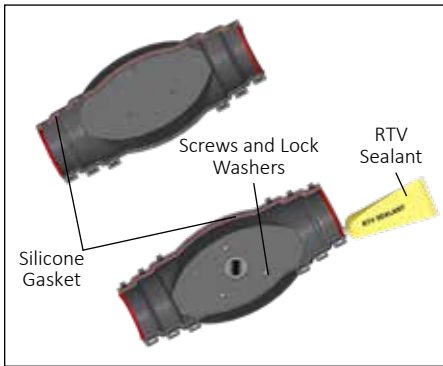

13. Install silicone gasket and cut off excess. Apply RTV sealant to both halves.

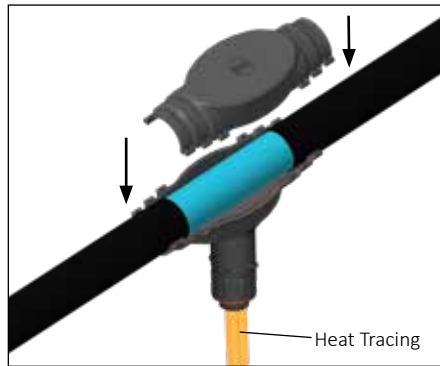

14. Assemble splice cover top, tubing bundle, and splice cover base together as shown. Snap together firmly. Inspect ends of tubing splice cover for snug fit. Apply additional RTV sealant where needed.



15. Apply self-vulcanizing tape around bundle jacket and work up over FAK ends.

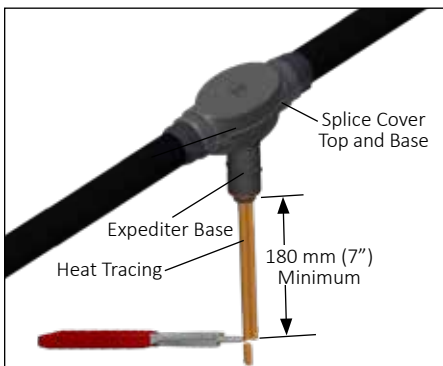

16. Trim heat tracing to 180 mm (7") minimum from expediter base.

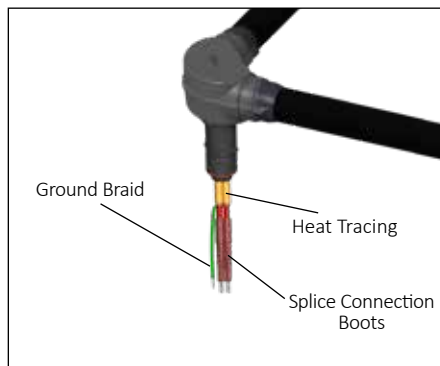

17. Terminate heat tracing with appropriate SCKT termination kit. Refer to SCKT installation instructions (purchased separately) for details not addressed here.

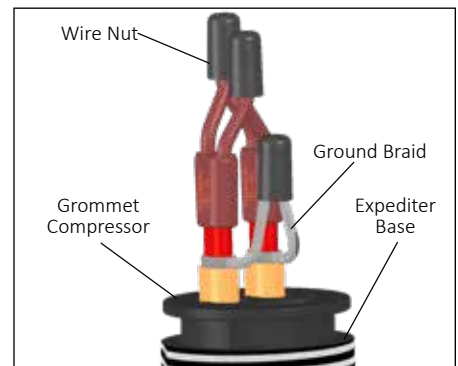

18. For splice connections: Connect bus wire using medium wire nuts (for HPT). Connect braid wire using large wire nut. See wiring details for splice connections.

INSTALLATION PROCEDURES

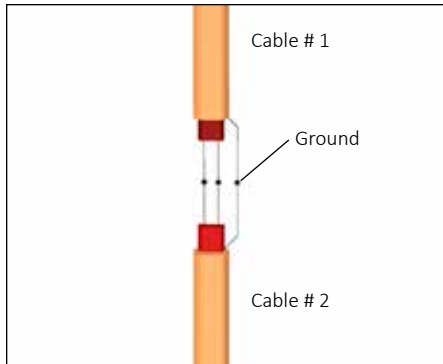

19. Complete system wiring between fabricated heat tracing.

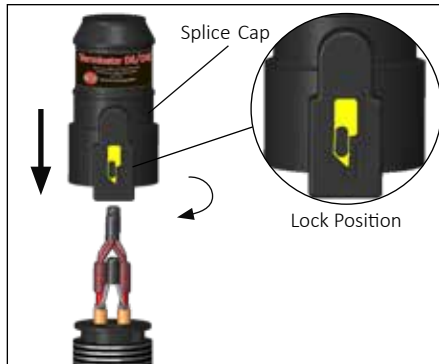

20. Mount splice cap to Terminator base, tighten securely. Make sure latch mechanism is in the locked position.



21. To remove splice cap, lift latch mechanism to unlock position (as shown) and unscrew.



22. Complete Terminator DS/DE FAK-4LHT Kit for Electrically Heated TubeTrace Bundles. Tighten connection cap securely.

