

# Terminator ZP/FAK-4 and FAK-4L

In-Line Splice Kit for Electrically  
Heated TubeTrace® Bundles

## INSTALLATION PROCEDURES



# Terminator ZP/FAK-4 and FAK-4L

The following installation procedures are suggested guidelines for the installation of the Terminator ZP/FAK-4 and 4L In-Line Splice Kit.

## Receiving, Storing and Handling

1. Inspect materials for damage incurred during shipping.
2. Report damages to the carrier for settlement.
3. Identify parts against the packing list to ensure the proper type and quantity has been received.
4. Store in a dry location.

## Terminator ZP/FAK-4 and 4L Kit Contents



Item	Quantity	Description
1	1	Expediter Assembly: Flat Mount Base, Grommet, Threaded Grommet Compressor, and Support Cap with O-Ring
2	1	Junction Box Lid
3	1	Junction Box Base with O-Ring
4	1	Nut
5	1	Terminal Blocks with DIN Rail (Refer to terminal specifications for maximum allowable wire size)
6	1	Junction Box Cord
7	1	In-Line Splice Cover (Top)
8	1	In-Line Splice Cover (Bottom)
9	1	Heat Reflective Tape
10	2 (FAK-4) 3 (FAK-4L)	RTV Sealant Tube
11	1	Glass Fiber Tape
12	1	Silicone Gasket
13	1	Self-Vulcanizing Tape

## Dimensions

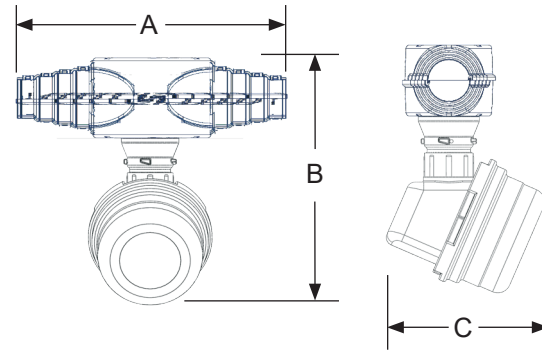

	A mm (inch)	B mm (inch)	C mm (inch)
Terminator ZP/ FAK-4	279 mm (11")	289 mm (11-3/8")	185 mm (7")
Terminator ZP/ FAK-4L	489 mm (19-1/4")	305 mm (12")	185 mm (7")

**Required: Order Separately for each heater to be fabricated. PETK Power and End Termination Kits (one req'd. per heater)**

- PETK-1 for BSX, RSX, VSX-HT
- PETK-2 for KSX, HTSX
- PETK-3 for FP, HPT







## Tools Required



# INSTALLATION PROCEDURES

The Terminator ZP/FAK-4 and 4L In-Line Splice Kit is designed to make a waterproof seal over the end of TubeTrace at the splice connections. Review instructions prior to installation. Kit will make one splice connection (Tube fittings not included). See separate instructions for details on splicing heat tracing.

## Terminator ZP Certifications/Approvals

-  IP66/Type 4X -60°C ≤ Ta ≤ +55°C  
Listed Heat Tracing Cable System 137M  
Ordinary & Hazardous Locations
-  Class I, Division 2, Groups A, B, C, & D  
Class II, Division 2, Groups F & G, Class III
-  Class I, Zone 1, AEx eb IIC T4-T6  
09.2238691,-G,-S, Ex e IIC T4-T6
-  FMG 10.0022X Ex eb IIC T4-T6, Ex tb IIIC T135°C-T85°C
-  1725  II 2 GD Ex eb IIC T4-T6, Ex tb IIIC T135°C-T85°C FM 10ATEX0058X

## Installation Precautions

- To minimize the potential for arcing and ground-fault protection. The National Electrical Code (NEC) and Canadian Electrical Code (CEC) require ground-fault protection of equipment for each branch circuit supplying electric heat tracing.
- Installation must comply with Thermon requirements and be installed in accordance with the NEC, CEC, or any other applicable national and local codes.
- Component approvals and performance ratings are based on the use of Thermon specified parts only. User supplied power connection fittings must be listed or certified for intended use.
- De-energize all power sources before opening enclosure.
- Keep ends of heating cable and kit components dry before and during installation.
- Individuals installing these products are responsible for complying with all applicable safety and health guidelines. Proper personal protective equipment, or PPE, should be utilized during installation. Contact Thermon if you have any additional questions.

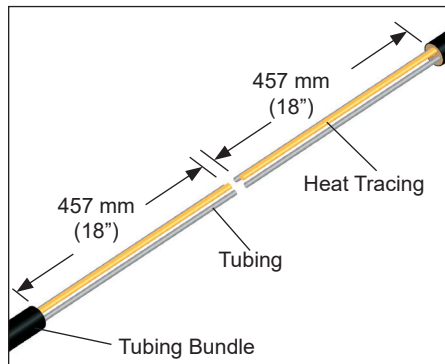

1. Remove outer jacket and insulation from tubing bundle approximately 457 mm (18") from end of the tubing bundle.

 Do not cut or damage the heat trace or sampling tube.

### CAUTION

(Found on TubeTrace SE/ME bundles)

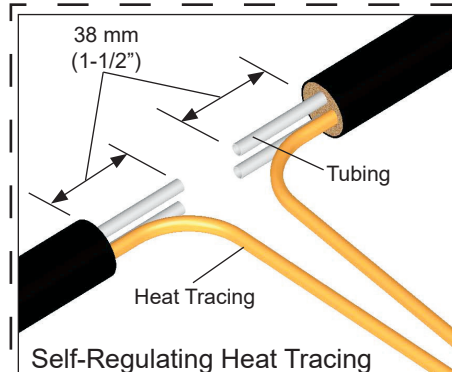

2. Trim tubing to within 38 mm (1-1/2") of the end of the insulation. If self regulating heat trace proceed to step 3. For Zone-type heat trace continue with identification of bus connection on step 2a.

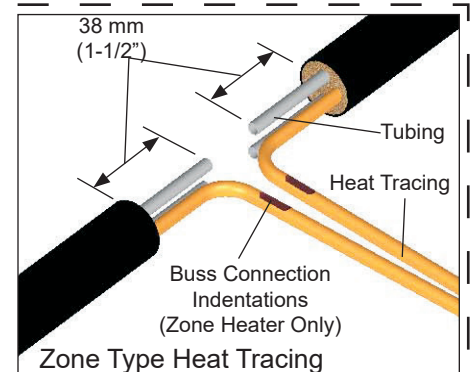

- 2a. Strip back bundle insulation 38 mm (1-1/2") to 76 mm (3") beyond bus connection indentation of each heat tracing. If bus connection indentation is less than 305 mm (12") to 381 mm (15") from end of the heat tracing, proceed stripping the bundle insulation to the next indentation. Trim tubes so the bus connection indentation on each meet.

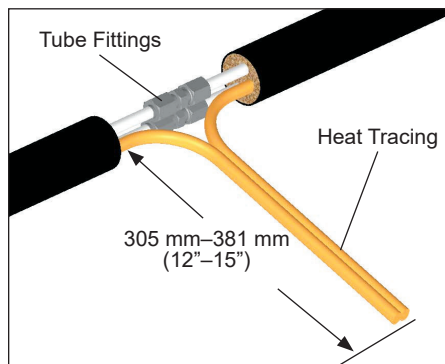

3. Make tube fitting connections with appropriate fittings (provided by others). Test fittings for leaks before proceeding.

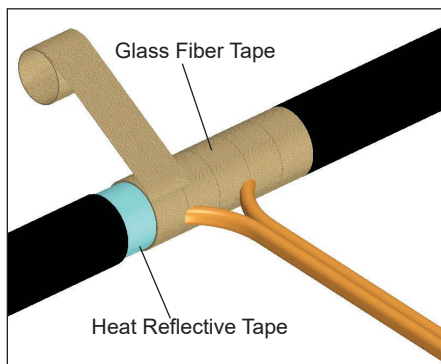

4. Wrap tubes and heat tracing with pass of heat reflective tape (25% overlap). Then wrap with 3 passes of glass fiber tape (50% overlap), or until fiber tape is equal to original bundle insulation thickness.

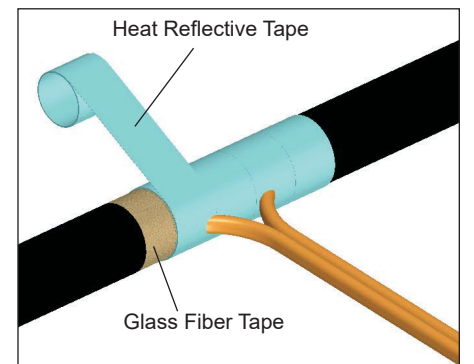

5. Complete with additional passes of heat reflective tape.

# Terminator ZP/FAK-4 and FAK-4L

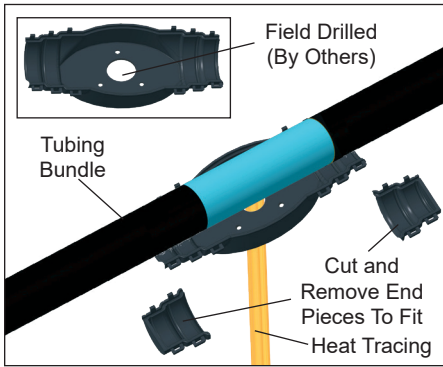

6. Cut splice cover ends to match outside diameter of tubing bundle. Field drill expediter base holes.

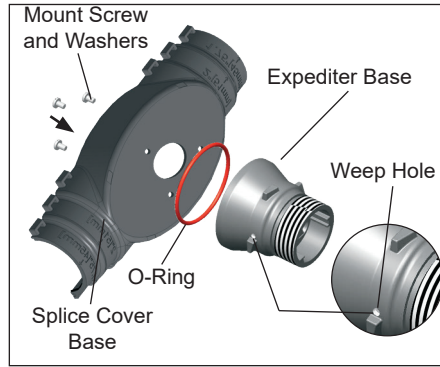

7. Mount expediter base with o-ring to the splice cover base using (3) M5 mounting screws and lock washers. Punch out weep hole.

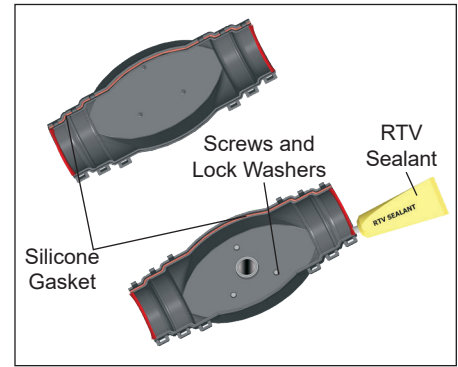

8. Install silicone gasket and cut off excess. Apply RTV sealant to both halves.

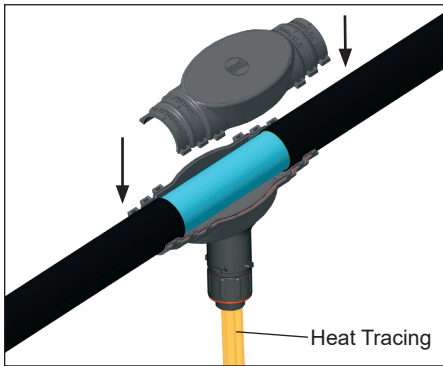

9. Assemble splice cover top, tubing bundle, and splice cover base together as shown. Snap together firmly. Inspect ends of tubing splice cover for snug fit. Apply additional RTV sealant where needed.

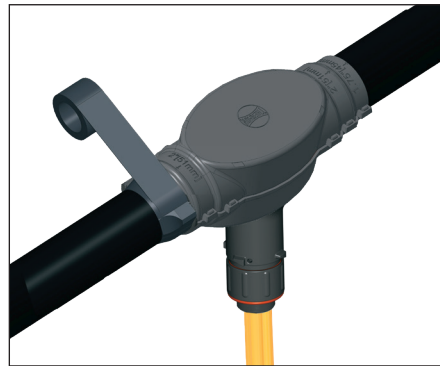

10. Apply self-vulcanizing tape around bundle jacket and work up over FAK ends.

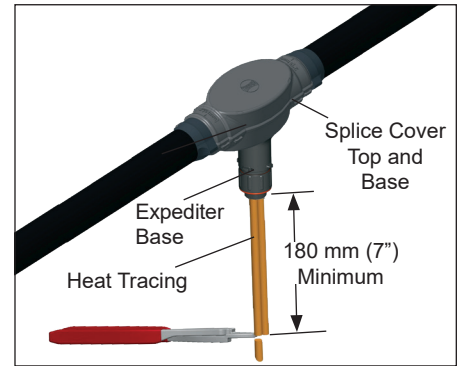

11. Trim heat tracing to 180 mm (7") minimum from expediter base.

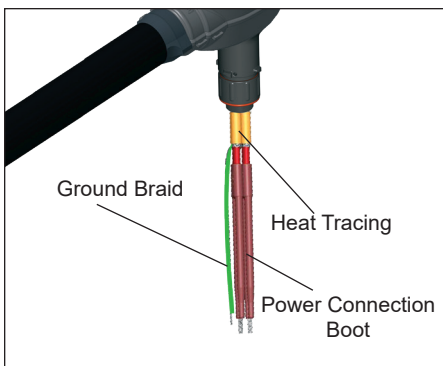

12. Terminate heat tracing with appropriate PETK termination kit. Refer to PETK installation instructions (purchase separately) for details not addressed here.

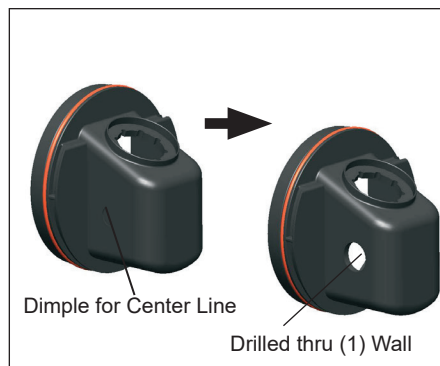

13. For power connection applications: Use dimple molded into side of junction box base to locate center hole, drill for user supplied power connection fitting per manufacture's recommendations.



14. Mount junction box on expediter making sure to align slots to properly orient junction box base.

# INSTALLATION PROCEDURES

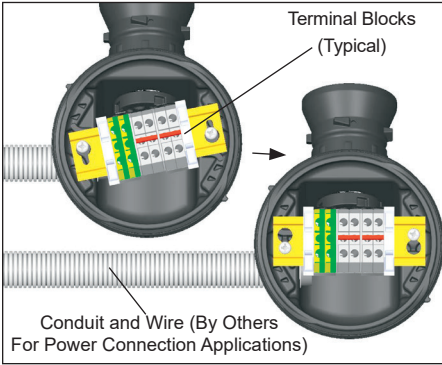

15. Install quick mount terminal blocks twist to position and tighten screws.

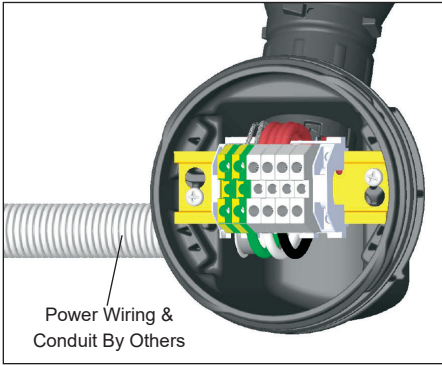

16. Complete system wiring per wiring diagram.

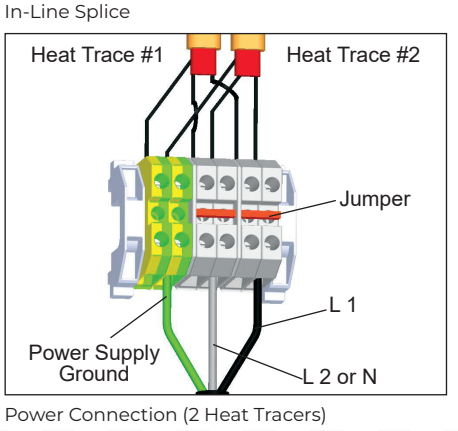
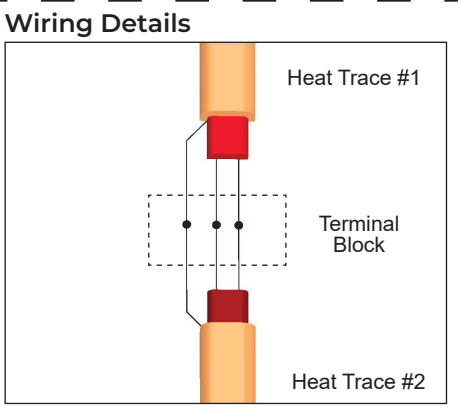

17. Install junction box lid and twist hand tight. Insert screwdriver into ratchet slot located on side of junction box base to tighten. Lid will rotate 30°.



18. Lid latch mechanism fully engaged. To remove lid, repeat step 17 but in opposite direction.

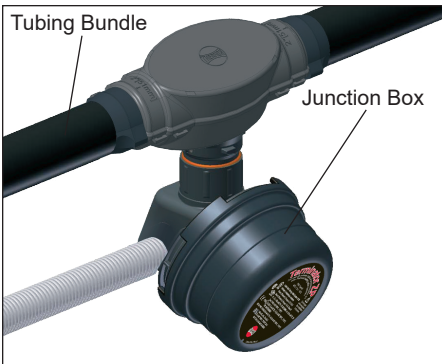

19. Completed Terminator ZP/FAK-4/4L power assembly for TubeTrace Type SE/ME Bundle (Installation shown is to feed power in the middle of a TubeTrace bundle. Many installations will be near the end of a TubeTrace bundle.)

