

Terminator ZP/FAK-5 and 5L for Tee Splice of Electrically Heated TubeTrace Bundles INSTALLATION PROCEDURES



The Heat Tracing Specialists®

Terminator ZP/FAK-5 and 5L

The following installation procedures are suggested guidelines for the installation of the Terminator ZP/FAK-5 and 5L: Tee Splice kit.

Receiving, Storing and Handling . . .

1. Inspect materials for damage incurred during shipping.
2. Report damages to the carrier for settlement.
3. Identify parts against the packing list to ensure the proper type and quantity has been received.
4. Store in dry location.

Terminator ZP/FAK-5 and 5L Kit Contents . . .

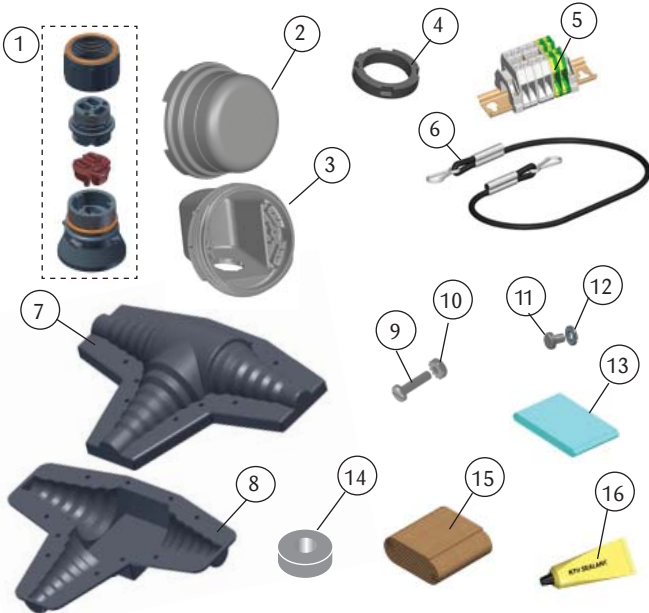

Item	Quantity	Description
1	1	Expediter Assembly: Flat Mount Base, Grommet, Threaded Grommet Compressor, and Support Cap with O-Ring
2	1	Junction Box Lid
3	1	Junction Box Base with O-Ring
4	1	Expediter Assembly Nut
5	5	Terminal Block (Typical)
6	1	Junction Box Cord
7	1	Tee Splice Top
8	1	Tee Splice Base
9	14	Pan Head S.S. Screws, #10-32 x .75" (19mm)
10	14	KEPT S.S. Nuts, #10-32
11	3	M5 Screw
12	3	M5 Lock Washer
13	1	Heat Reflective Tape
14	2	Small Bundle Adapters
15	1	Glass Fiber Tape
16	3	RTV Sealant Tube

INSTALLATION PROCEDURES

Dimensions . . .

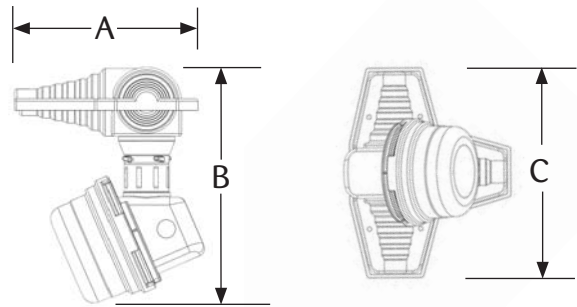

	A mm	B mm	C mm
Terminator ZP /FAK-5L	10.50" (267 mm)	11.80" (299 mm)	15.60" (397 mm)

Required: Order Separately for each heater to be fabricated. Refer to PETK Instruction, Form PN50136U for additional information.

PETK Power and End Termination Kits (one req'd. per heater)

- PETK-1 for BSX, RSX, VSX
- PETK-2 for KSX, HTSX
- PETK-3 for FP, HPT

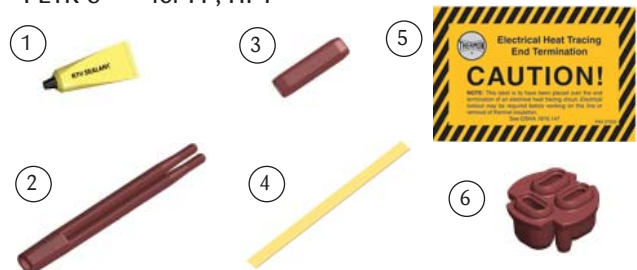

Item	Quantity	Description
1	1	RTV Sealant Tube
2	1	TBX Power Connection Boots
3	1	ET End Cap
4	1	Tape Strip Teflon 6" (150mm) (PETK-3 only)
5	1	End Termination Caution Label
6	1	GRW-G Grommet (PETK-3 only)

Tools Required . . .

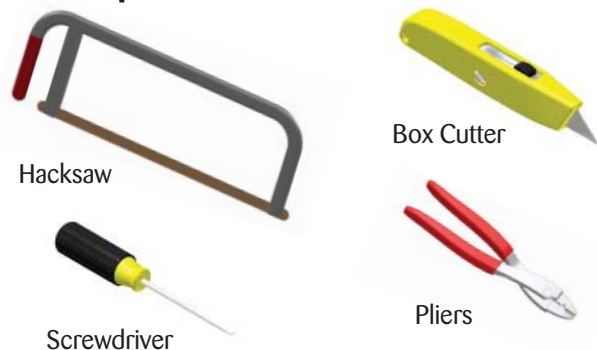

The Heat Tracing Specialists®

Terminator ZP/FAK-5 and 5L

INSTALLATION PROCEDURES

The Terminator ZP/FAK-5 and 5L Tee Splice Kit is designed to make a waterproof seal over the end of TubeTrace at the tee splice connections. Review instructions prior to installation. Kit will make one splice connection (Tube fittings not included). See separate instructions for details on splicing heat tracing.

Terminator ZP Certifications/Approvals . . .

CENELEC European Organisation for Electrotechnical Standardisation
Hazardous (Classified) Locations

CE 1725 Ex II 2 GD Ex eb IIC T4-T6, Ex tb IIIC T135°C-T85°C FM 10ATEX0058X

IEC IECEx FMG 10.0022X Ex eb IIC T4-T6, Ex tb IIIC T135°C-T85°C

FM Approved FM Approvals
Hazardous (Classified) Locations

UL LISTED Underwriters Laboratories Inc.
Hazardous (Classified) Locations

Terminator has additional hazardous area approvals including:

- GGTN • Kazakhstan

Installation Precautions . . .

- To minimize the potential for arcing on electrical heat tracing and fire caused by product damage or improper installation, use ground-fault protection.
- Installation must comply with Thermon requirements and be installed in accordance with any applicable national and local codes.
- Component approvals and performance ratings are based on the use of Thermon specified parts only. User supplied power connection fittings must be listed or certified for intended use.
- De-energize all power sources before opening enclosure.
- Keep ends of bundles, heat tracing and kit components dry before and during installation.
- Individuals installing these products are responsible for complying with all applicable safety and health guidelines. Proper personal protective equipment, or PPE, should be utilized during installation. Contact Thermon if you have any additional questions.

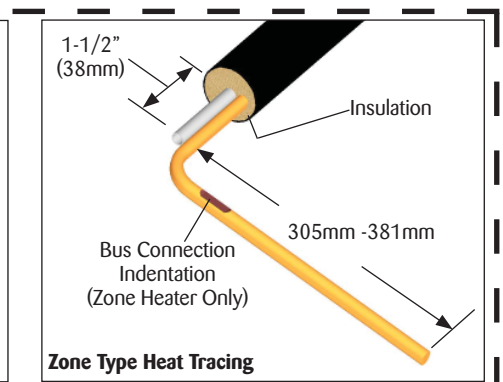
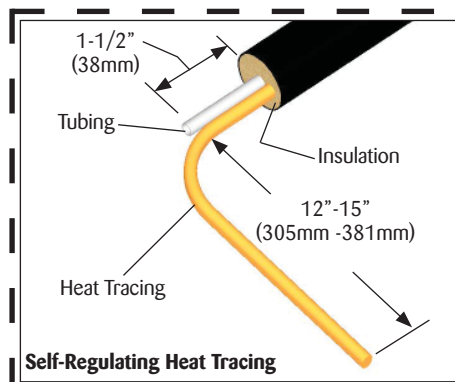
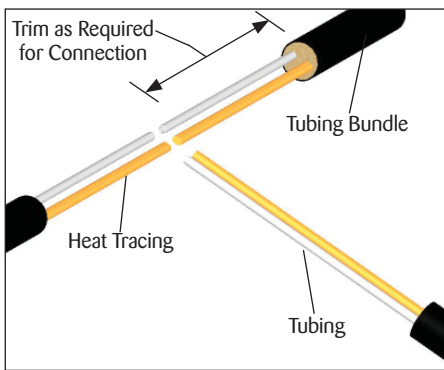

1. Remove outer jacket and insulation from tubing bundle to the required length for making connections.



Do not cut or damage the heat trace.
(Found on TubeTrace SE/ME bundles)

2. Trim heat tracing to within 12"-15" (305mm-381mm) of the end of the insulation. If self-regulating heat trace proceed to step 3. For Zone type heat trace continue with identification of bus connection on step 2a.

2a. Strip back bundle jacket and insulation 1-1/2" (38mm) beyond bus connection indentation of each heat tracing. If bus connection indentation is less than 12"-15" (305mm-381mm) from end of the heat tracing, proceed stripping the bundle jacket and insulation to the next indentation.

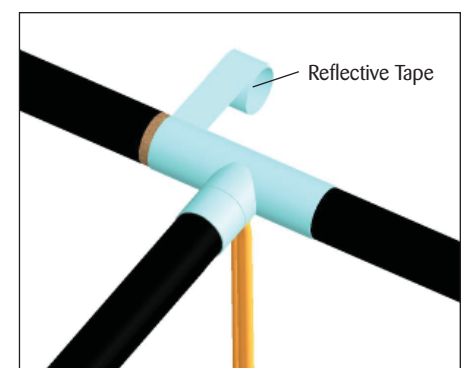
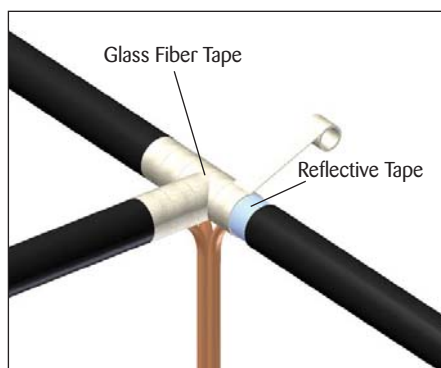
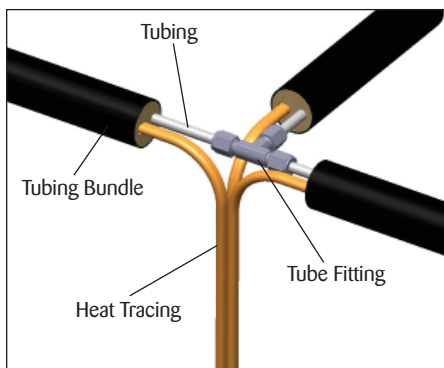

3. Make tube connections with appropriate fittings, provided by others. Test fittings for leaks before proceeding.

4. Wrap tube and heat trace with 1 pass of reflective tape (25% overlap), then wrap with 3 passes of glass fiber tape (50% overlap), or until fiber tape is equal to original bundle insulation thickness.

5. Complete with additional passes of heat reflective tape.

Terminator ZP/FAK-5 and 5L

INSTALLATION PROCEDURES

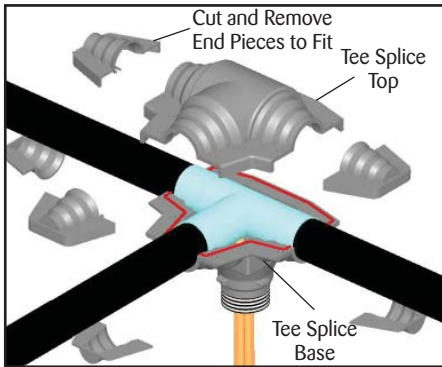

6. Cut FAK-5L top and base to match outside diameter of tubing bundle and remove end pieces.

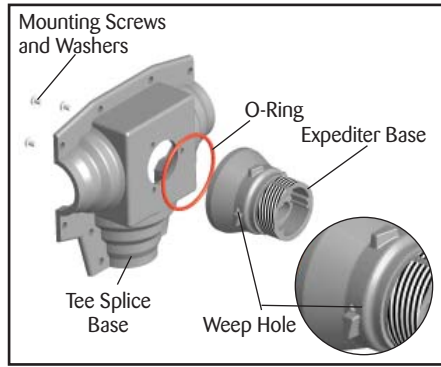

7. Mount Expediter Base with O-Ring to bottom cover using (3) mounting screws and lock washers. Punch out weep hole.

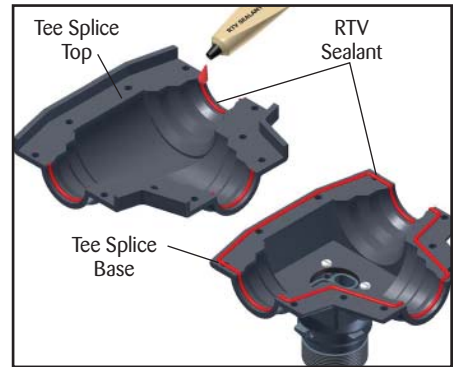

8. Form a gasket by applying RTV sealant to the FAK-5L top and base. Fit tubing bundle to bottom half of cover and install top half. Screw down firmly. Inspect ends of tubing splice cover for snug fit. Apply additional RTV sealant where needed.

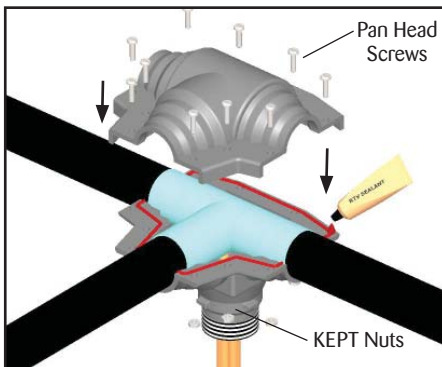

9. Assemble FAK-5L Top, tubing bundle, and FAK-5L base together as shown, using (14) 10-32 x .75" (19mm) pan head screws, and (14) KEPT nuts.

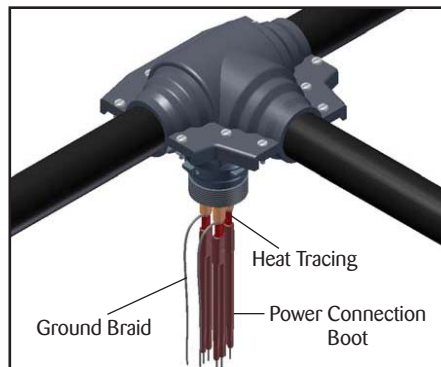

10. Terminate heat tracing with appropriate PETK termination kit. Refer to PETK installation instructions for details (not addressed here).

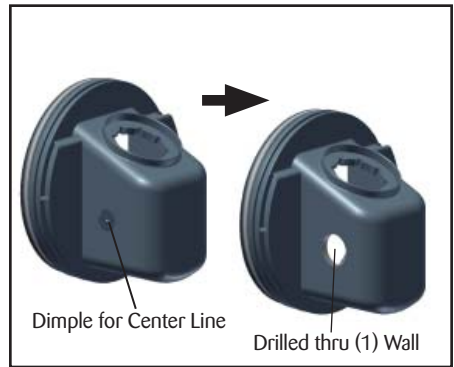

11. For power connection applications: Use dimple molded into side of junction box base to locate center hole, drill for user supplied power connection fitting per manufacture's recommendations.



12. Mount junction box on expediter making sure to align slots to properly orient junction box base.

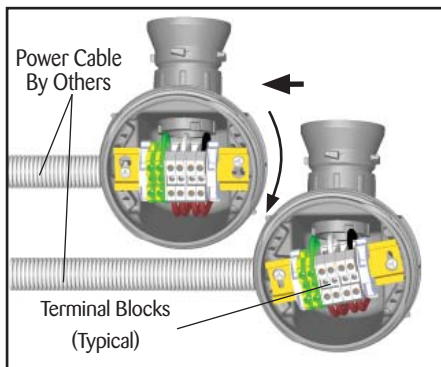

13. Install quick mount terminal blocks twist to position and tighten screws.

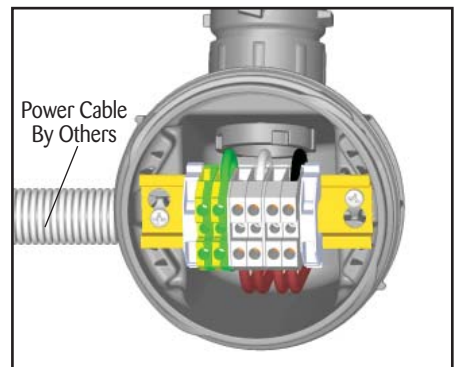

14. Complete system wiring per wiring diagram.



The Heat Tracing Specialists®

Terminator ZP/FAK-5 and 5L

INSTALLATION PROCEDURES

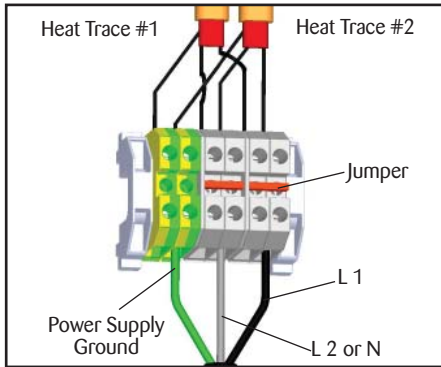

Typical Wiring Diagram

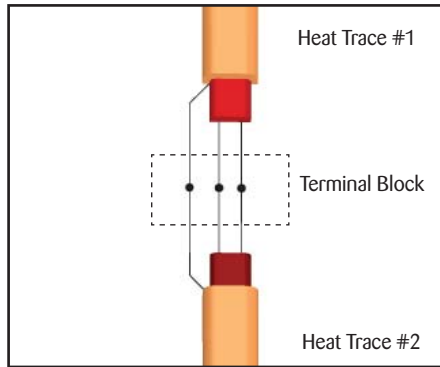

In-Line Splice Wiring Diagram



- 15.** Install junction box lid and twist hand tight. Insert screwdriver into ratchet slot located on side of junction box base to tighten. Lid will rotate 30°.

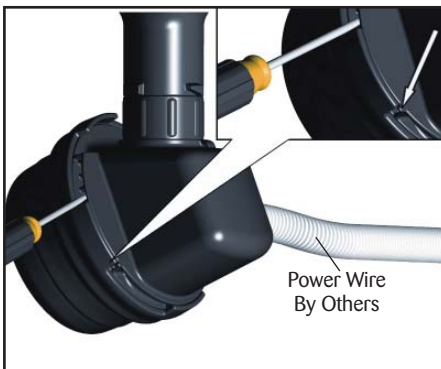

- 16.** Lid latch mechanism fully engaged. To remove lid, repeat step 14 but in opposite direction.

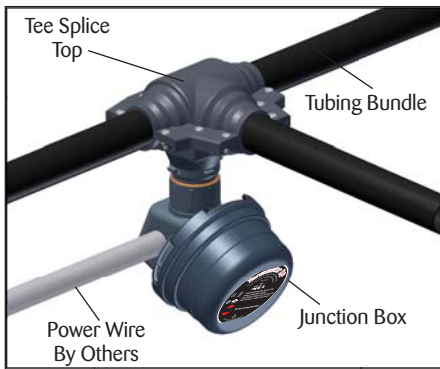

- 17.** Completed Terminator DP/FAK-5L for Tee Splice power assembly for TubeTrace Type SE/ME Bundle (Installation shown is to feed power in kit junction box. Many installations will be for splice only, without power feed to the electrical heat tracing circuits.)



ISO 9001
REGISTERED

THERMON . . . The Heat Tracing Specialists®
www.thermon.com

European Headquarters
Boezemweg 25 • PO Box 205
2640 AE Pijnacker • The Netherlands
Phone: +31 (0) 15-36 15 370

Corporate Headquarters
100 Thermon Dr. • PO Box 609
San Marcos, TX 78667-0609 • USA
Phone: +1 512-396-5801

For the Thermon office nearest you
visit us at . . .

www.thermon.com

Specifications and information are subject to change without notice. Form PN50086-0612