

# Terminator DS/DE FAK-2LHT

Elbow Splice Kit for  
Electrically Heated  
TubeTrace® Bundles

## INSTALLATION PROCEDURES



# Terminator™ DS/DE FAK-2LHT

The following installation procedures are suggested guidelines for the installation of the Terminator DS/DE FAK-2LHT Kit.

## Receiving, Storing and Handling

1. Inspect materials for damage incurred during shipping.
2. Report damages to the carrier for settlement.
3. Identify parts against the packing list to ensure the proper type and quantity has been received.
4. Store in a dry location.

## Terminator DS/DE FAK-2LHT Kit Contents



Item	Quantity	Description
1	1	Expediter Assembly: Flat Mount Base, Grommet, Threaded Grommet Compressor, and Support Cap with O-Ring
2	1	Splice Cap
3	1	90° Splice Cover (Top)
4	1	90° Splice Cover (Base)
5	1	Nut
6	1	Heat Reflective Tape
7	3	RTV Sealant Tube
8	1	Glass Fiber Tape
9	1	Silicone Gasket
10	1	Self-Vulcanizing Tape
11	1	Fiberglass Rope, 13 mm x 366 cm (1/2" x 12')
12	1	Heavy Foil Tape, 44.5 mm (1.75") wide

**REQUIRED:** Order separately for each heater to be fabricated.

## SCTK Splice Connection Termination Kits (per cable)

- SCTK-1D for BSX, RSX, VSX-HT  
 SCTK-2D for KSX, HTSX  
 SCTK-3D for FP, HPT

## Dimensions

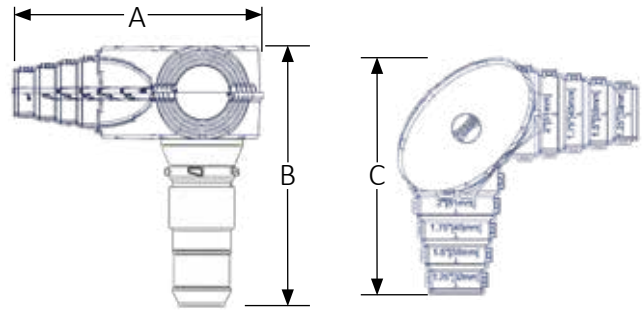

	A	B	C
	mm (inch)	mm (inch)	mm (inch)
Terminator DS/DE FAK-2LHT	328 mm (12-7/8")	321 mm (12-5/8")	328 mm (12-7/8")

## Warnings

- To minimize the potential for arcing on electrical heat tracing and fire caused by product damage or improper installation, use ground-fault protection. The National Electrical Code (NEC) and Canadian Electrical Code (CEC) require ground-fault protection of equipment for each branch circuit supplying electrical heat tracing.
- Installation must comply with Thermon requirements and be installed in accordance with the NEC, CEC, or any other applicable national and local codes.
- Component approvals and performance ratings are based on the use of Thermon specified parts only. User supplied power connection fittings must be listed or certified for intended use.
- De-energize all power sources before opening enclosure.
- Keep ends of heating cable and kit components dry before and during installation.
- Individuals installing these products are responsible for complying with all applicable safety and health guidelines. Proper personal protective equipment, or PPE, should be utilized during installation. Contact Thermon if you have any additional questions.

## Terminator DS/DE Certifications/Approvals

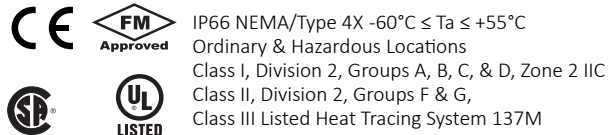

## Tools Required



# INSTALLATION PROCEDURES

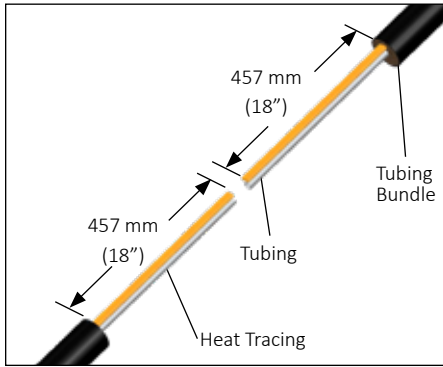

1. Remove outer jacket and insulation from tubing bundle approximately 457 mm (18") from end of the tubing bundle.



Do not cut or damage the heat trace or sampling tube.  
**CAUTION** (Found on TubeTrace SE/ME bundles)

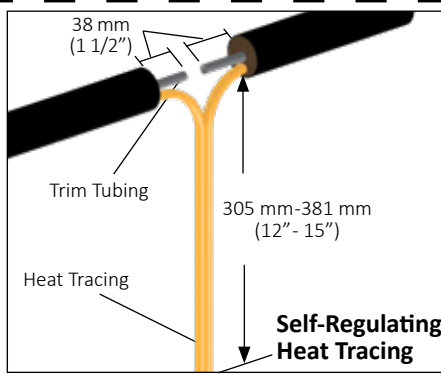

2. Trim tubing to within 38 mm (1-1/2") of the end of the insulation. If self regulating heat trace proceed to step 3. For Zone-type heat trace continue with identification of bus connection on step 2a.

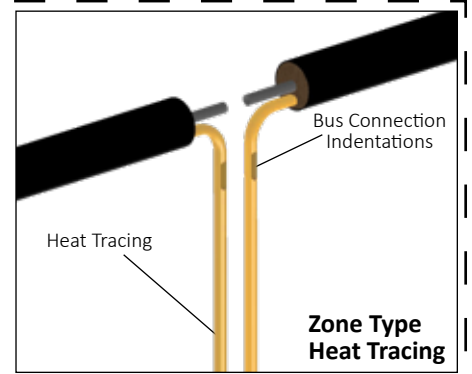

- 2a. Strip back bundle insulation 38 mm (1 1/2") to 76 mm (3") beyond bus connection indentation of each heat trace. If bus connection indentation is less than 305 mm (12")- 381 mm (15") from end of the heat tracing, proceed stripping the bundle insulation to the next indentation.

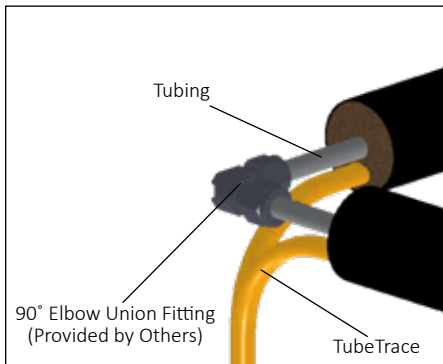

3. Make 90° elbow union connections (fitting provided by others). Test fitting for leaks before proceeding.

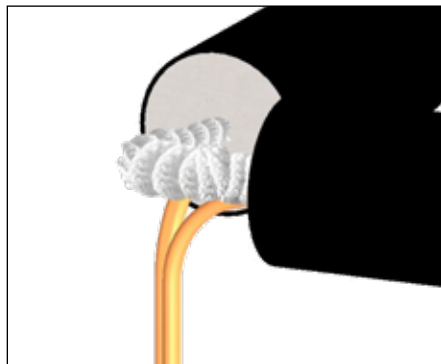

4. Wrap high temperature tubing with 1/2" fiberglass rope. Ensure 100% coverage to keep tubing and heat tracing from making contact.



5. Wrap with 1 pass of heavy foil tape (25% overlap).  
**DO NOT wrap heat trace with fiberglass rope.**

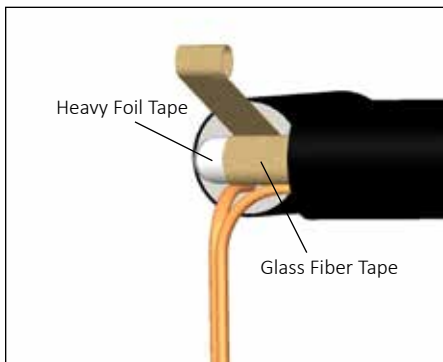

6. Wrap with 3 passes of glass fiber tape (50% overlap).

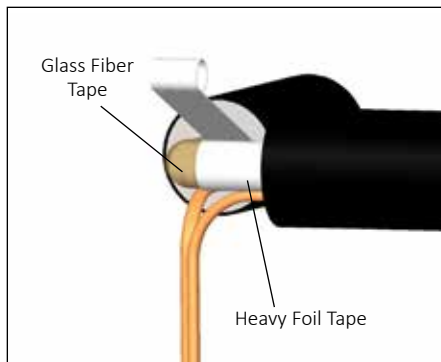

7. Complete with 1 additional pass of heavy foil tape (25% overlap).

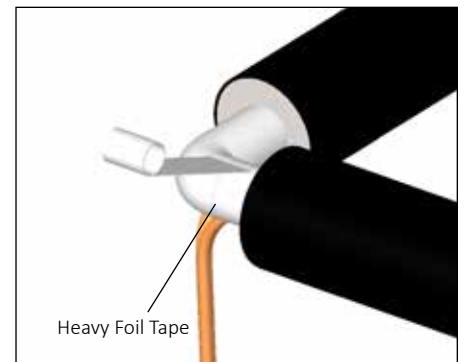

8. Add 1 additional pass of heavy foil tape (25% overlap) to cover heat trace.

# Terminator™ DS/DE FAK-2LHT

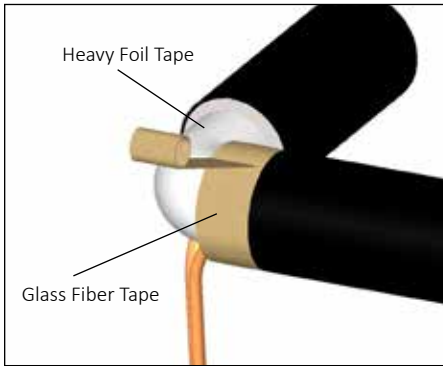

**9.** Wrap with 4 passes of glass fiber tape (50% overlap), or until fiber tape is equal to original bundle insulation thickness.

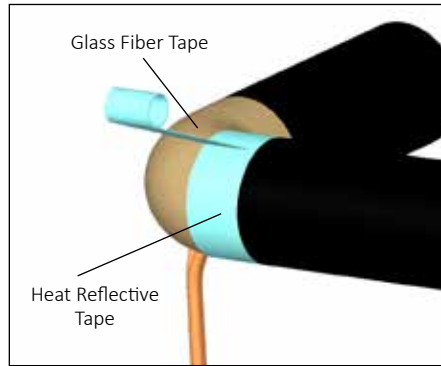

**10.** Wrap with 1 additional pass of heat reflective tape (50% overlap).

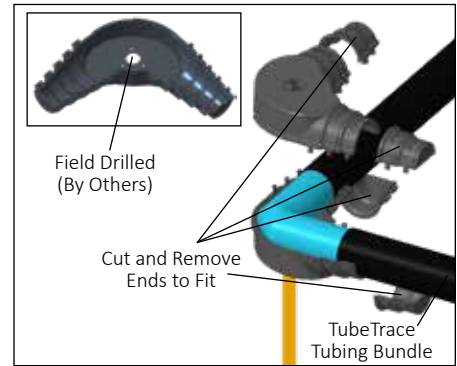

**11.** Cut splice cover top and splice cover bottom to match outside diameter of tubing bundle.

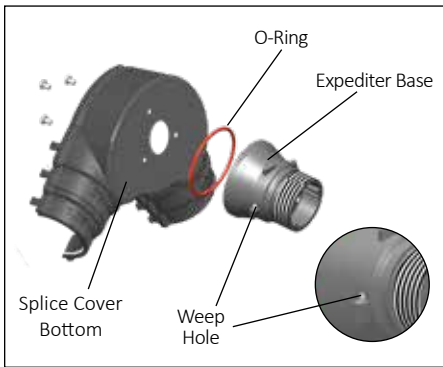

**12.** Mount expediter base with o-ring to splice cover bottom using (3) M5 mounting screws and lock washers. Punch out weep hole.

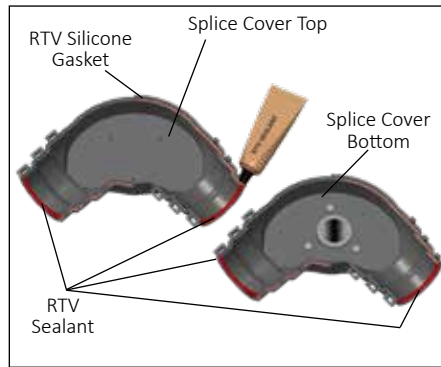

**13.** Install the Silicone Gasket (cut off excess). Apply RTV Sealant to both halves.

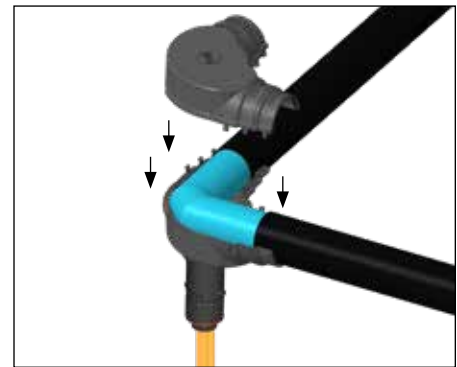

**14.** Assemble splice cover top, tubing bundle, and splice cover bottom together as shown Snap together firmly. Inspect ends of tubing splice cover for snug fit. Apply additional RTV sealant where needed.



**15.** Apply self-vulcanizing tape around bundle jacket and work up over FAK ends.

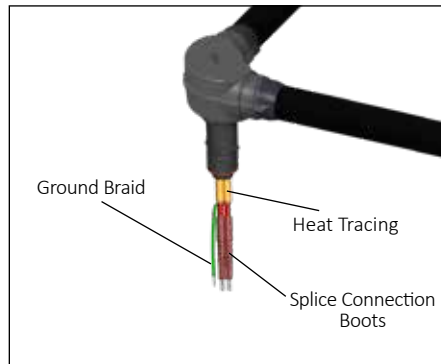

**16.** Terminate heat tracing with appropriate SCTK termination kit. Refer to SCTK installation instructions (purchased separately) for details not addressed here.

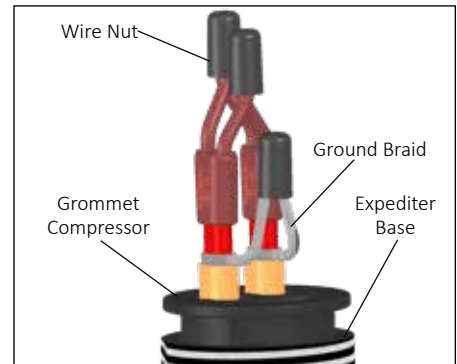

**17.** For splice connections: Connect bus wire using small wire nuts (for BSX, HTSX, KSX) or medium wires. (for RSX, VSX-HT, HPT, and FP). Connect braid wire using large wire nut. See wiring details for splice connections.

# INSTALLATION PROCEDURES

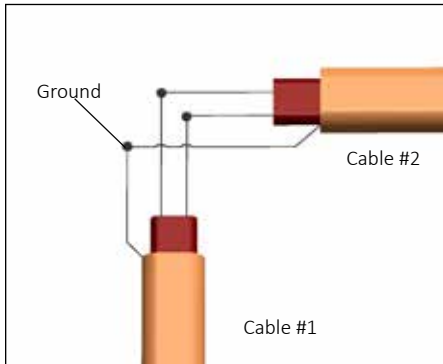

**18.** Complete system wiring between fabricated heat tracing.

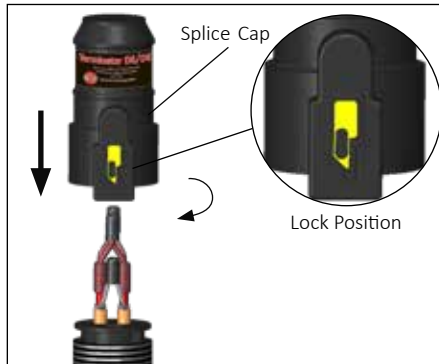

**19.** Mount splice cap to Terminator base, tighten securely. Make sure latch mechanism is in the locked position.



**20.** To remove splice cap, lift latch mechanism to unlock position (as shown) and unscrew.



**21.** Complete Terminator DS/DE FAK-2LHT Kit for Electrically Heated TubeTrace Bundles. Tighten connection cap securely.

