

Terminator ZE-B/FAK-1
LED End of Circuit Light Kit for
Electrically Heated
TubeTrace® Bundles
INSTALLATION PROCEDURES



Terminator ZE-B/FAK-1

The following installation procedures are suggested guidelines for the installation of the Terminator ZE-B/FAK-1 Bulkhead Entry Kit.

Receiving, Storing and Handling

1. Inspect materials for damage incurred during shipping.
2. Report damages to the carrier for settlement.
3. Identify parts against the packing list to ensure the proper type and quantity has been received.
4. Store in a dry location.

Terminator ZE-B/FAK-1 Kit Contents



Item	Quantity	Description
1	1	Expediter Assembly: Flat Mount Base, Grommet, Grommet Compressor.
2	1	Light Module Cover
3	1	LED Light Module
4	1	FAK-1 Top
5	1	FAK-1 Base
6	1	Heat Reflective Tape, 1.75" Wide
7	1	Glass Fiber Tape
8	2	RTV Sealant Tube
9	1	Silicone Gasket
10	1	Self-Vulcanizing Tape

8 each stainless steel bolts, nuts and washers required (by others) for mounting. 8-32 size recommended.

Required: Order separately for each heater to be terminated.

When using wire connector connection option:

SCTK Connection Termination Kits (per cable)

SCTK-1D	for BSX, RSX, VSX-HT
SCTK-2D	for KSX, HTSX
SCTK-3D	for FP, HPT

When using terminal block connection option:

SCTK Terminal Block Connection Kits (per cable)

SCTK-1TB	for BSX, RSX, VSX-HT
SCTK-2TB	for KSX, HTSX
SCTK-3TB	for FP, HPT

Dimensions

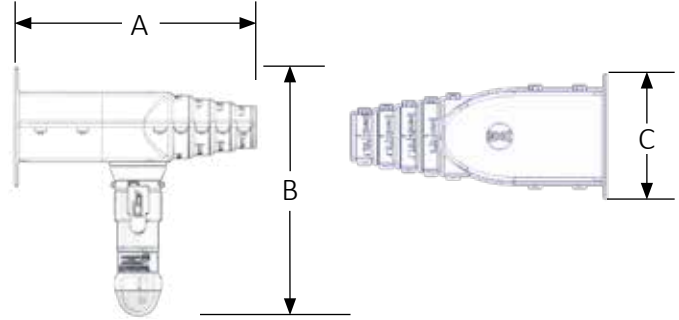

	A mm (inches)	B mm (inches)	C mm (inches)
Terminator ZE-B/FAK-1	220 mm (8-5/8")	340 mm (13-3/8")	107 mm (4-1/4")

Installation Precautions

- To minimize the potential for arcing on electrical heat tracing and fire caused by product damage or improper installation, use ground-fault protection. The National Electrical Code (NEC) and Canadian Electrical Code (CEC) require ground-fault protection of equipment for each branch circuit supplying electrical heat tracing.
- Installation must comply with Thermon requirements and be installed in accordance with the NEC, CEC, or any other applicable national and local codes.
- Component approvals and performance ratings are based on the use of Thermon specified parts only. User supplied power connection fittings must be listed or certified for intended use.
- De-energize all power sources before opening enclosure.
- Keep ends of bundles, heat tracing and kit components dry before and during installation.
- Individuals installing these products are responsible for complying with all applicable safety and health guidelines. Proper personal protective equipment, or PPE, should be utilized during installation. Contact Thermon if you have any additional questions.

Terminator ZE-B Certifications/Approvals



Class I, Division 2, Groups A, B, C, & D
Class II, Division 2, Groups F & G, Class III



Class I, Zone 1, AEx eb mb IIC T6; 09.2238691,-G,-S, Ex e mb IIC T6
Zone 21 AEx tb IIIC T85°C



1725 Ex II 2 G&D Ex eb mb IIC T6, Ex tb IIIC T85°C, FM 10ATEX0058X



FMG 10.0022X Ex eb mb IIC T6, Ex tb IIIC T85°C

Tools Required



INSTALLATION PROCEDURES

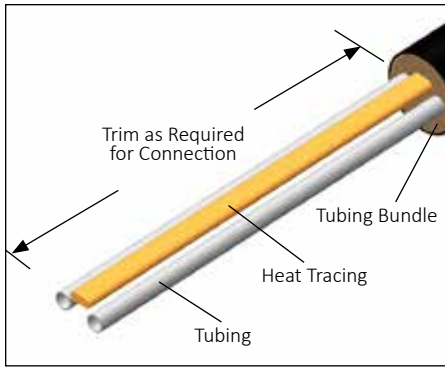

1. Remove outer jacket and insulation from tubing bundle as included from end of the tubing bundle. Ensure sufficient heat trace is available for electrical connection. See instructions included with heat trace SCTK kit.



Do not cut or damage the heat trace or sampling tube.

CAUTION (Found on TubeTrace SE/ME bundles)

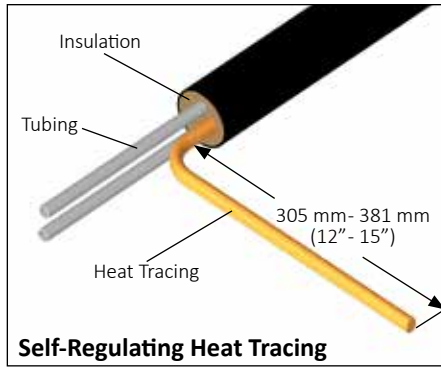

Self-Regulating Heat Tracing

2. Trim heat tracing to within 305 mm - 381 mm (12" - 15") of the end of the insulation. If self regulating heat trace proceed to step 3. For Zone-type heat trace continue with identification of bus connection on step 2a.

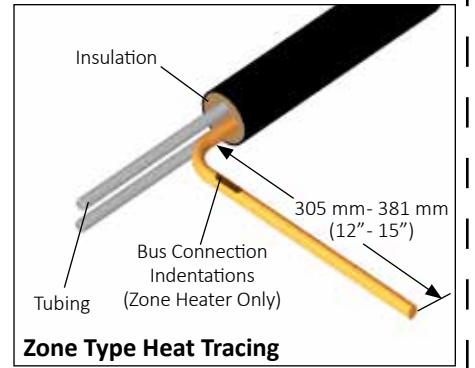

Zone Type Heat Tracing

2a. Strip back bundle insulation 38 mm (1 1/2") to 76 mm (3") beyond bus connection heat tracing. If bus connection indentation is less than 305 mm (12") - 381 mm (15") from end of the heat tracing, proceed stripping the bundle insulation to the next indentation.

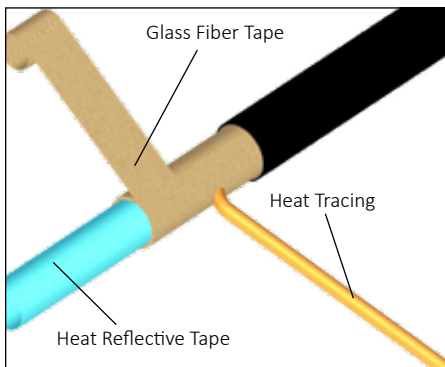

3. Wrap tubes and heat tracing with pass of heat reflective tape (25% overlap). Then wrap with 3 passes of glass fiber tape (50% overlap), or until fiber tape is equal to original bundle insulation thickness.

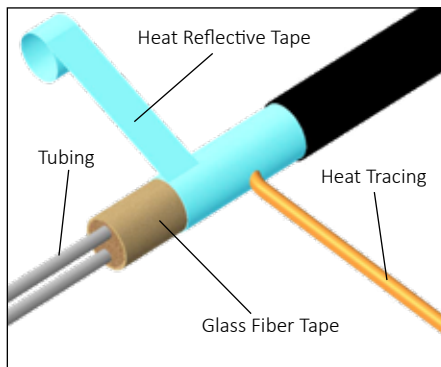

4. Complete with additional passes of heat reflective tape.

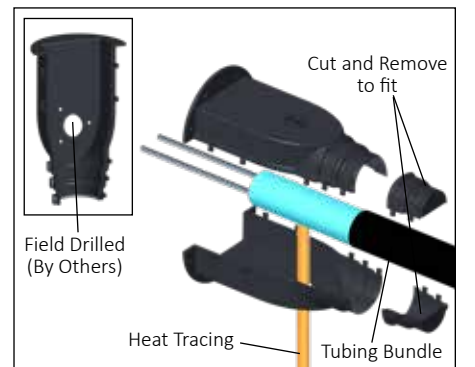

5. Cut FAK-1 top and base ends to match outside diameter of tubing bundle and remove end pieces.

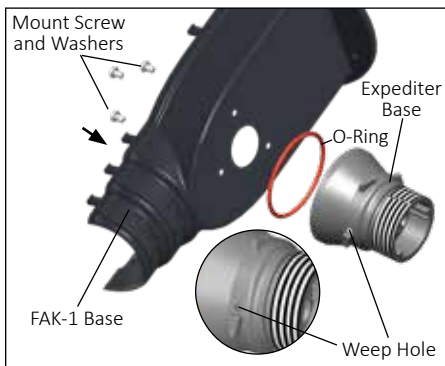

6. Mount expediter base with o-ring to FAK-1 base using (3) M5 mounting screws and lock washers. Punch out weep hole.

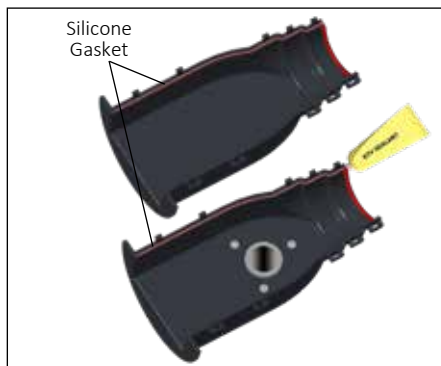

7. Install RTV silicone and gasket, cutting off excess. Apply RTV sealant to both halves.

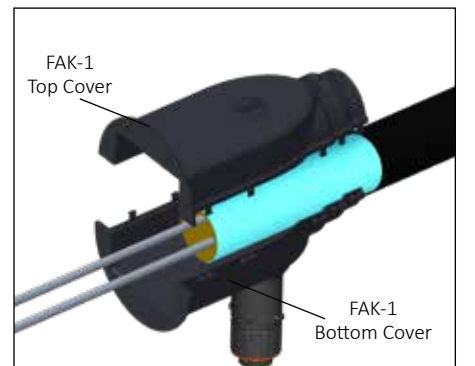

8. Assemble FAK-1 top, tubing bundle, and FAK-1 bottom together as shown. Snap together firmly. Inspect ends of tubing splice cover for snug fit. Apply additional RTV sealant where needed.

Terminator ZE-B/FAK-1



9. Apply self-vulcanizing tape around bundle jacket and work up over FAK ends.

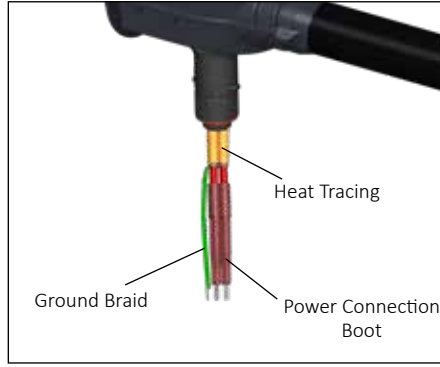

10. Terminate heat tracing with appropriate SCTK termination kit. Refer to SCTK installation instructions for details (not addressed here).

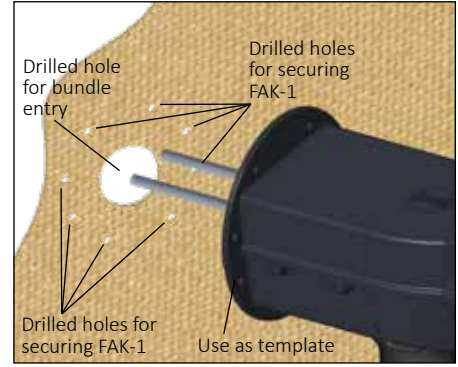

11. Field drill required entry hole in wall/plate. Use the FAK-1 flange as a template and mark and drill holes for bolts.

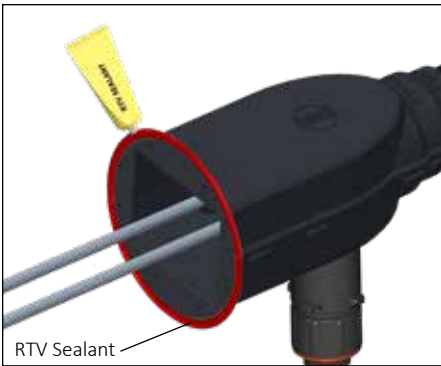

12. Apply RTV bead to back of FAK-1 flange prior to securing to bulkhead.

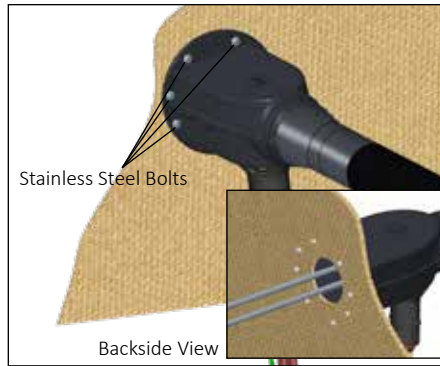

13. Secure FAK-1 to bulkhead/wall using (8) eight stainless steel bolts. Note: stainless steel bolts, washers, and nuts provided by others. Recommended bolt size is 8-32.

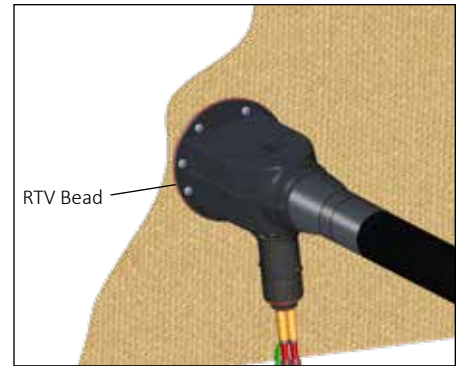

14. Apply RTV bead around FAK-1 flange.

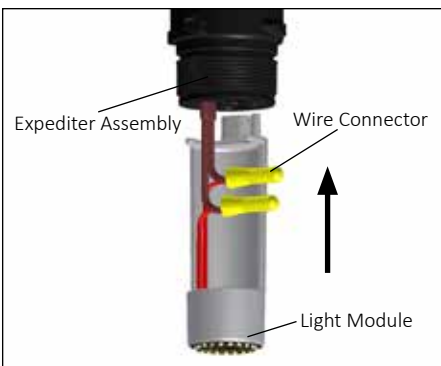

15. When using wire connector: Connect bus wires using small wire nuts (for BSX, HTSX and KSX) or medium wire nuts (for RSX, VSX, VSX-HT, HPT and FP).
When using terminal block: See steps 16–18. See wiring schematic for connection details.

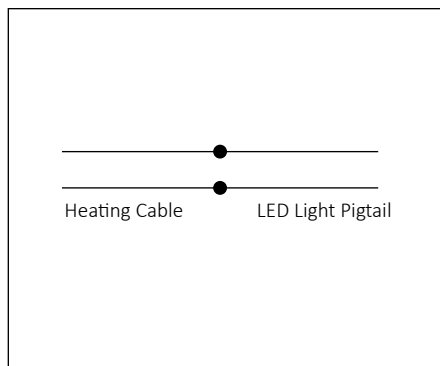

Wiring Schematic for LED Light

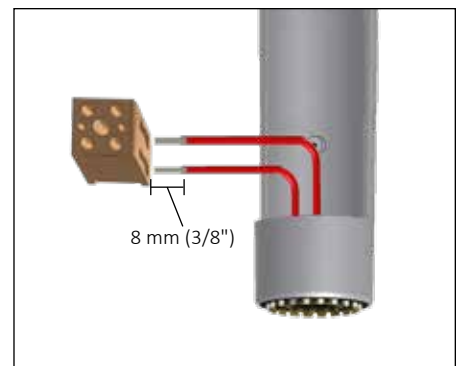

16. When using SCTK-TB Connection Kit, first trim exposed bus wires of the LED pigtail to 8 mm (.32"), then connect to the terminal block.

INSTALLATION PROCEDURES

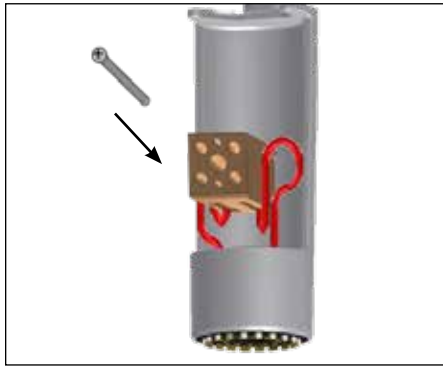

17. Use the terminal block mounting screw to mount terminal block to the LED light module. Bend each pigtail lead around the sides of the terminal block.



18. Connect the bus wires of the trace heater to the terminal block.

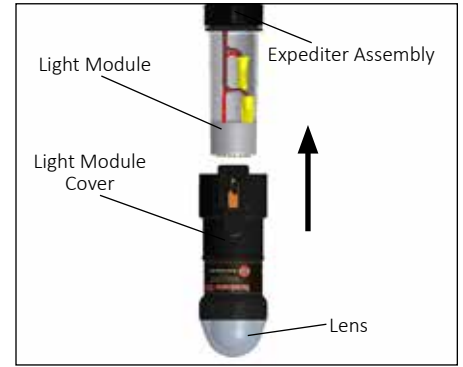

19. Slide the light module cover over light module.



20. Engage threads. Rotate light module cover clockwise and tighten cap securely. Make sure latch mechanism is in the locked position.

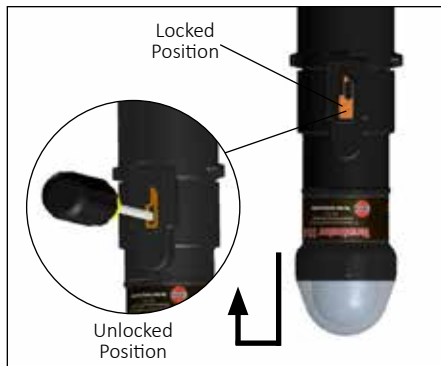

21. To remove cap, de-energize circuit, lift latch mechanism, and unscrew cap.

