

Lighted Power Connection / Lighted End Termination Kit Installation Instructions

Terminator DL-L

for use with RSX, TSX, VSX self-regulating heating cables

Terminator DL-S

for use with BSX*, HTSX, KSX self-regulating, HPT power-limiting,
and FP constant watt heating cables



For Power Connection (1 Cable - Standard, 2 Cables - w/ Optional Boot)
or End Termination (1 Cable) Applications





* BSX self-regulating heating cables may also be used with Terminator DL-L

Item	Qty	Description
1	1	Expediter Assembly Support Cap w/ O-ring Threaded Grommet Compressor Grommet Support Base w/ O-ring
2	1	Junction Box Lid
3	1	Junction Box Base w/ O-ring
4	1	Nut
5	1	Banding
6	1	RTV Tube
7	1	Power Connection Boot
8	1	Banding Guide
9	1	Lamp Terminal Blocks w/ DIN Rail (Refer to terminal specifications for maximum allowable wire size)
10	1	Junction Box Cord
11	1	Optional Power Connection Boot - for 2 cable power connection installations - not provided in kit

Tools Required



Certifications/Approvals



IP66 NEMA/Type 4X $-60^{\circ}\text{C} \leq \text{Ta} \leq +55^{\circ}\text{C}$
Ordinary & Hazardous Locations
Class I, Division 2, Groups A, B, C, & D, Zone 2 IIC

Class II, Division 2, Groups F & G, Class III
Listed Heat Tracing Cable System 137M

Warnings

- Due to the risk of electrical shock, arcing and fire caused by product damage or improper usage, installation or maintenance, a ground-fault protection device is required.
- Installation must comply with Therman requirements and be installed in accordance with the NEC, CEC, or any other applicable national and local codes.

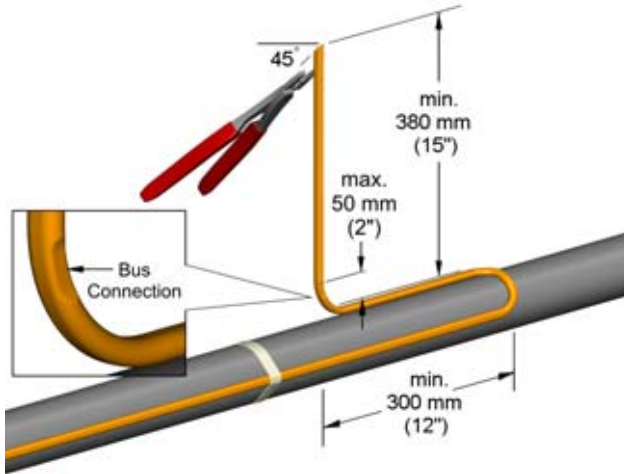

- Component approvals and performance ratings are based on the use of Therman specified parts only. User supplied power connection fittings must be UL Listed or certified for intended use.
- De-energize all power sources before opening enclosure.
- Keep ends of heating cable and kit components dry before and during installation.



1. Locate bus connection (HPT and FP only) and cable as shown. Cut end of cable at angle to aid in piercing grommet. Leave additional cable for expansion loop. See page 9 for multiple cable installation tips.

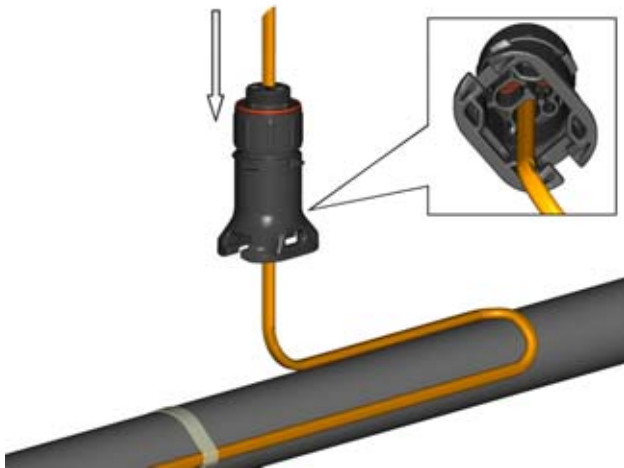

2. Insert cable into expeditor. If mounted on bottom of pipe, punch out weep hole.

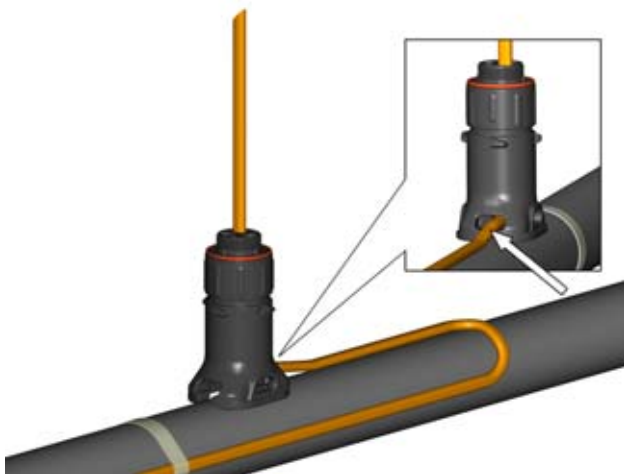

3. Slide expeditor toward pipe and route cable through support base entry.



4. Insert banding guide into expeditor and snap into place.

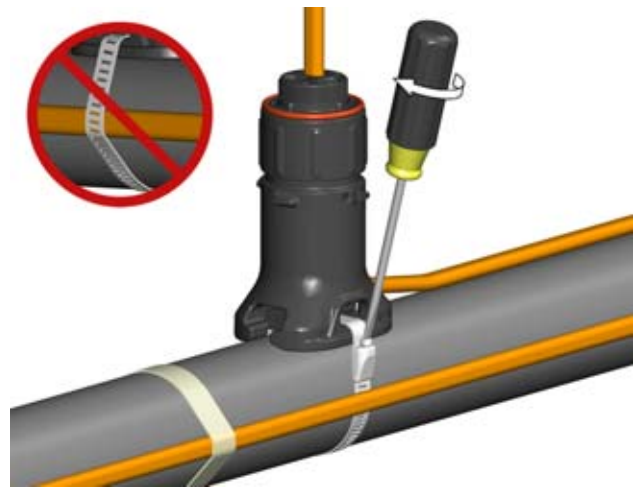

5. Mount expeditor to pipe using pipe band. Do not band over cable.

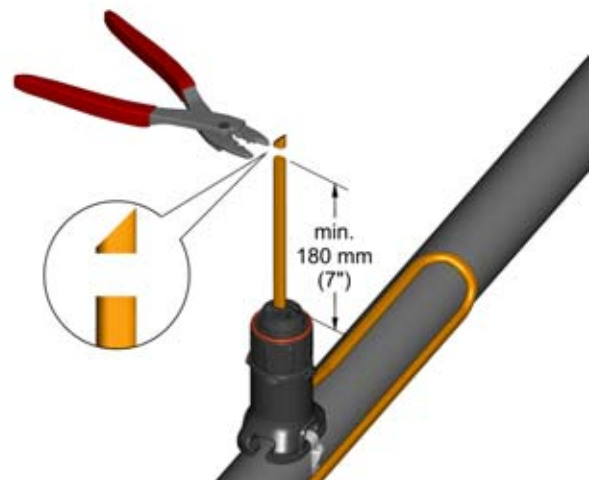

6. Cut off end of cable.



7. Terminate cable using cable termination (for BSX, HTSX, KSX, RSX, TSX, and VSX) on pages 11-14 or cable termination (for HPT and FP) on pages 15-18.

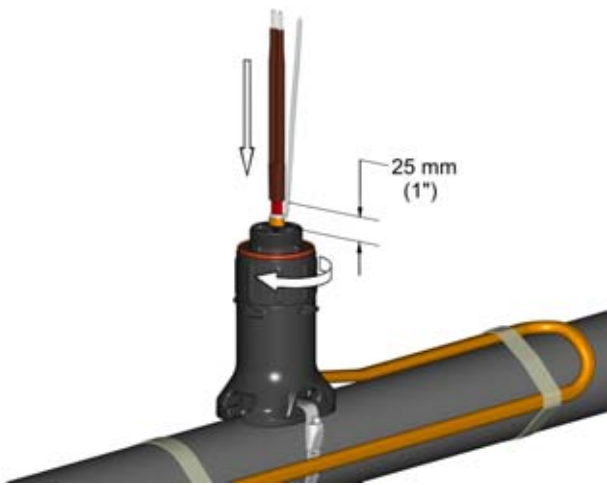

8. Push excess cable back through expediter. Tighten cap securely. Tape cable expansion loop to pipe.



9. Using dimple molded into side of junction box base to locate center of hole, drill for user supplied power connection fittings per manufacturer's recommendations (if necessary).



10. Mount junction box base on expediter. Make sure to align slots to properly orient junction box base.



11. Install power connection fittings (user supplied) and pull in power and ground wires (if necessary).

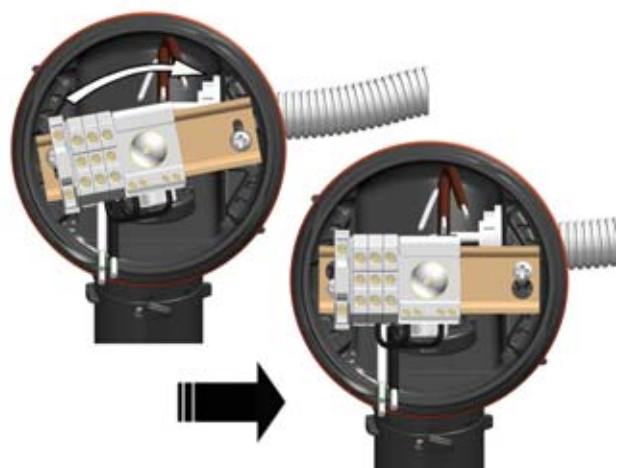

12. Install quick mount terminal blocks.



13. Complete system wiring. See page 20 for wiring details.

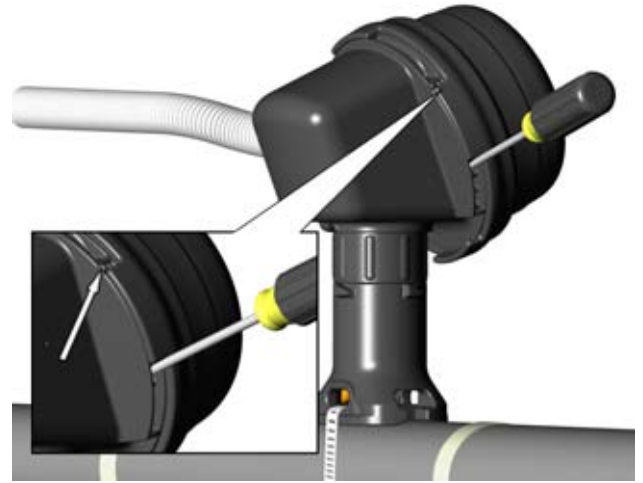

16. Lid latch mechanism fully engaged. To remove lid, repeat steps 14 and 15 but in the opposite direction.

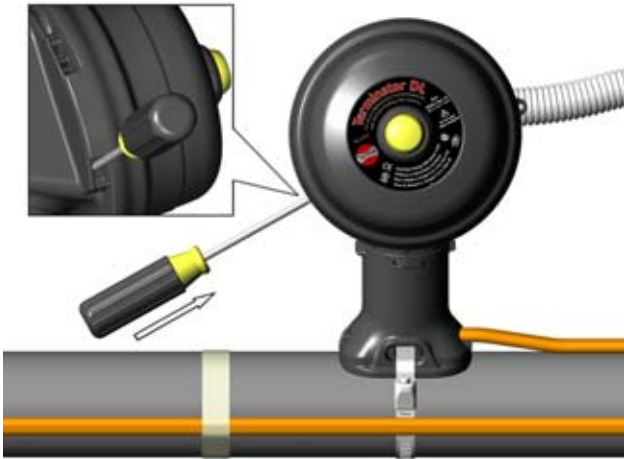

14. Install junction box lid and twist hand tight. Insert screwdriver into ratchet slots located on side of junction box base.



15. Use screwdriver to ratchet on junction box lid. Lid will rotate 30 degrees.

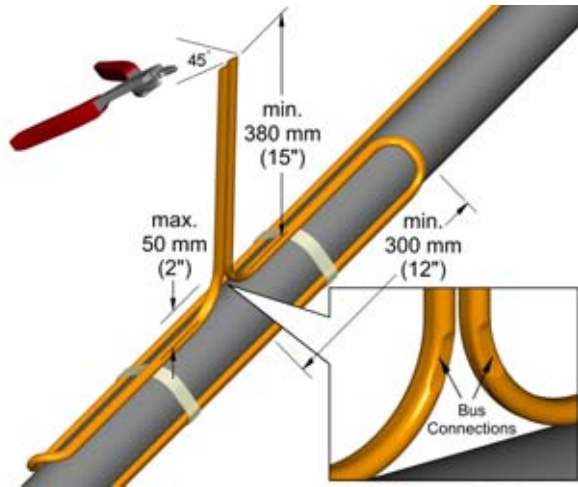

- A1. Locate bus connection (HPT and FP only) and cable as shown. Cut end of cable at angle to aid in piercing grommet. Leave additional cable for expansion loop.

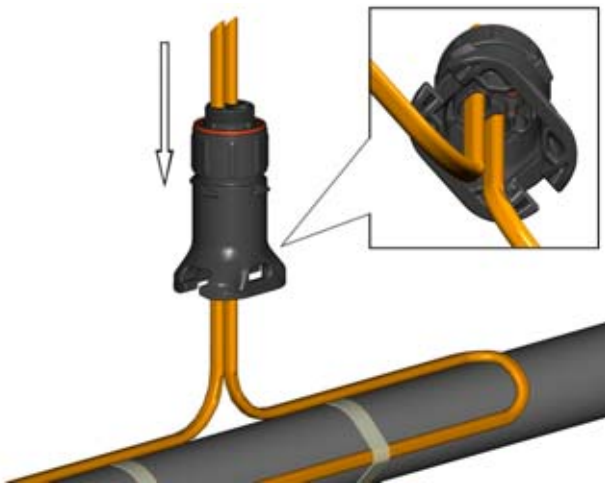

- A2. Insert two cables into expediter.



B1. Cut and remove overjacket. Do not cut metallic braid.

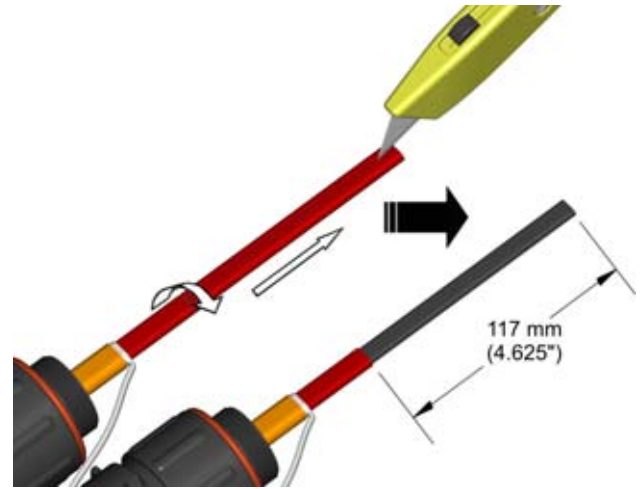

B4. Cut and remove primary insulation jacket. Omit this step for KSX, HTSX, and VSX cables.

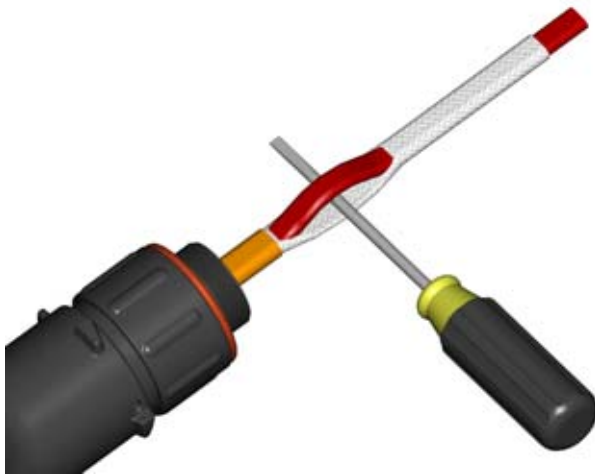

B2. Separate braid strands at edge of overjacket and pull cable through opening in braid.



B5. Skive outside edges of black matrix. Do not cut bus wire strands. See page 19 for TSX cable matrix removal tips.



B3. Twist braid into a pigtail. Trim ends of braid.

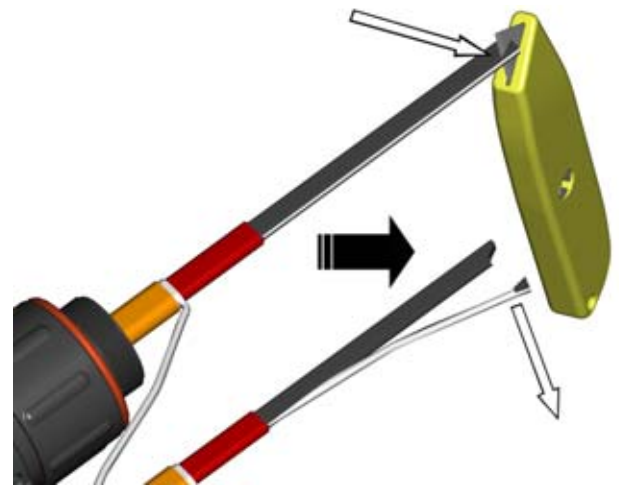

B6. Cut V-notch in matrix and pull bus wires from matrix.

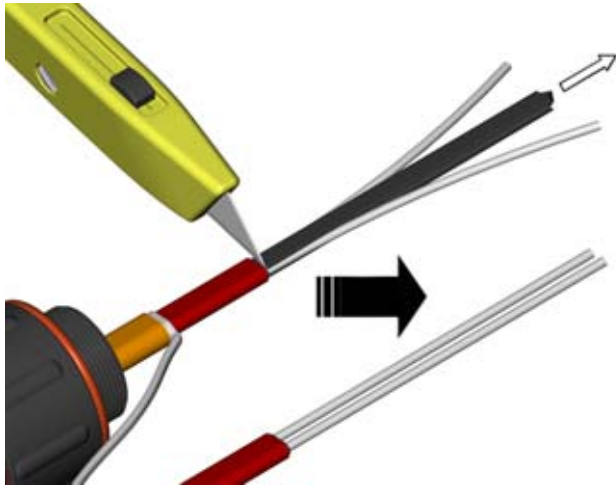

B7. Cut and remove remaining center core of matrix.

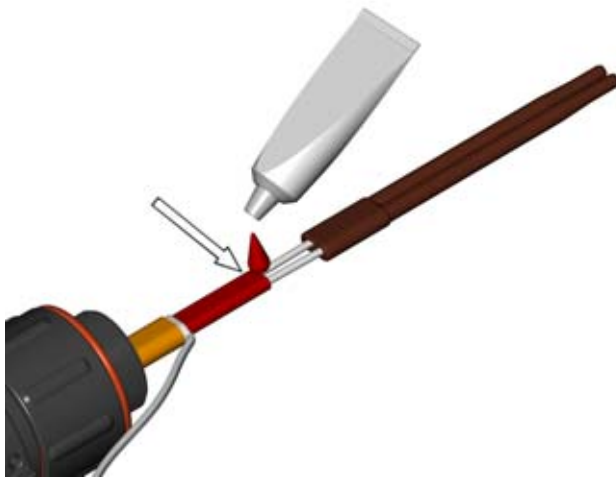

B8. Apply a liberal amount of RTV sealant to cable.

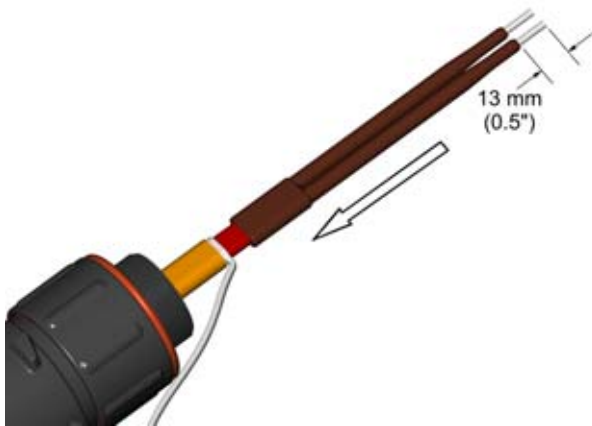

B9. Slide boot onto the end of the cable.

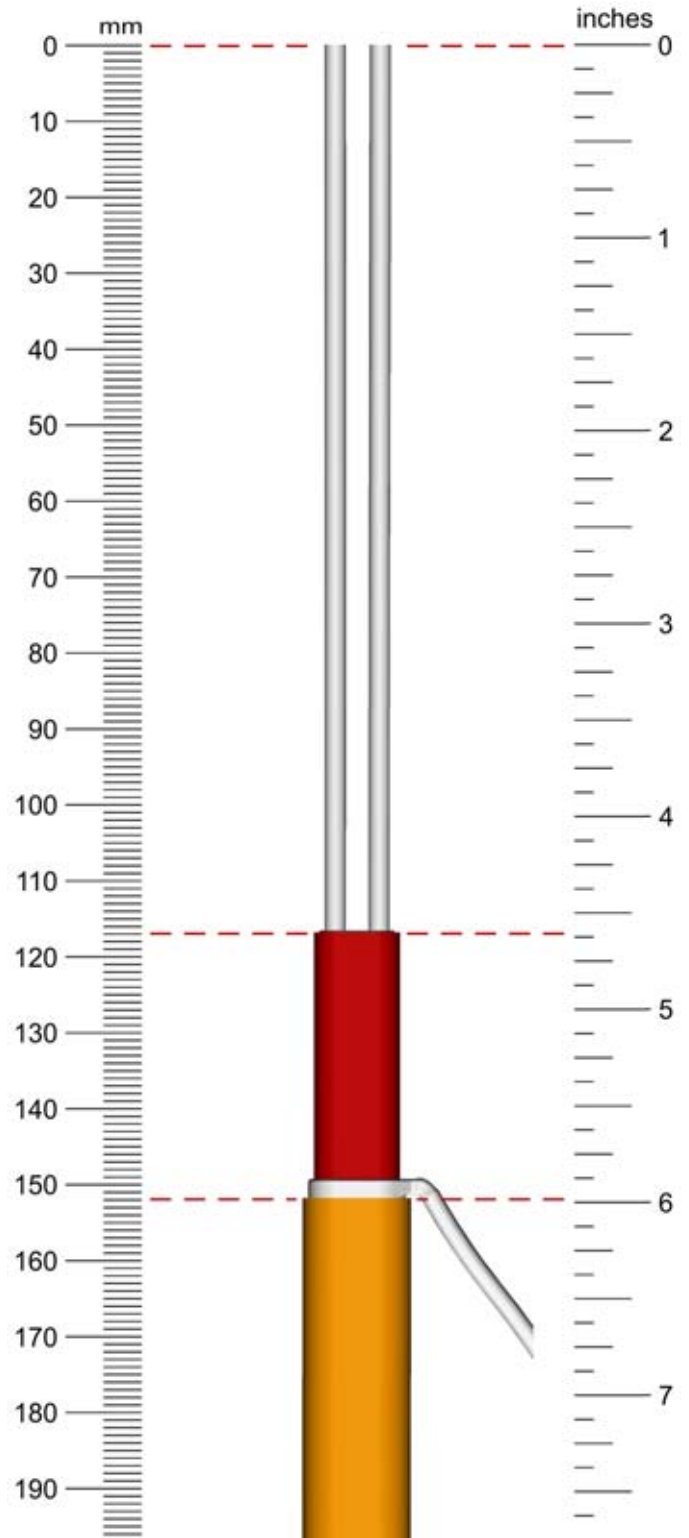

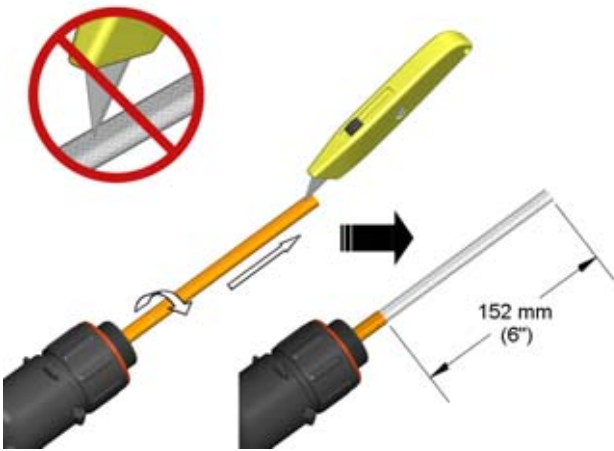

C1. Cut and remove overjacket. Do not cut metallic braid.

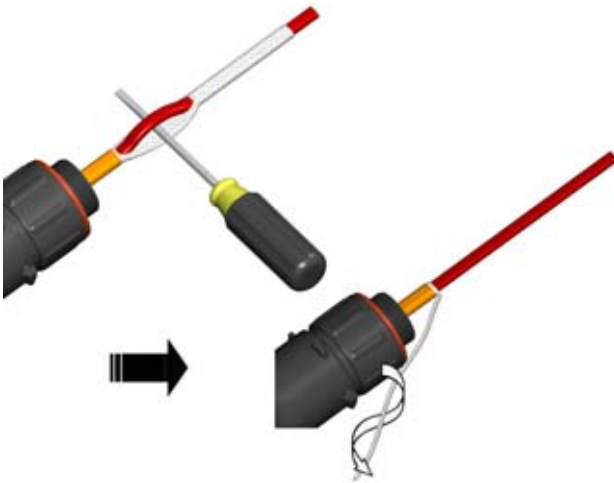

C2. Separate braid strands at edge of overjacket and pull cable through opening in braid. Twist braid into a pigtail. Trim ends of braid.

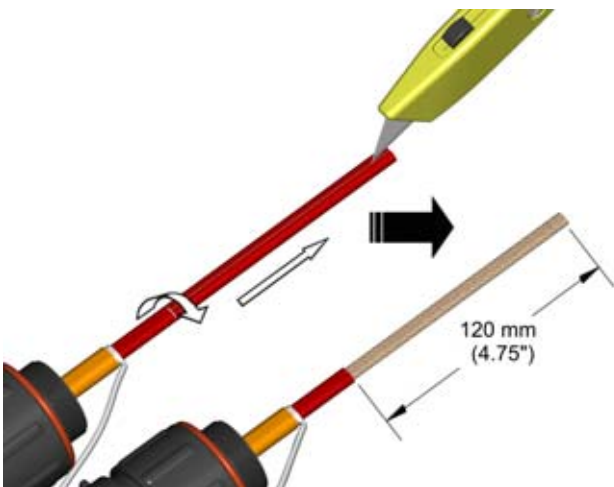

C3. Cut and remove primary insulation jacket.

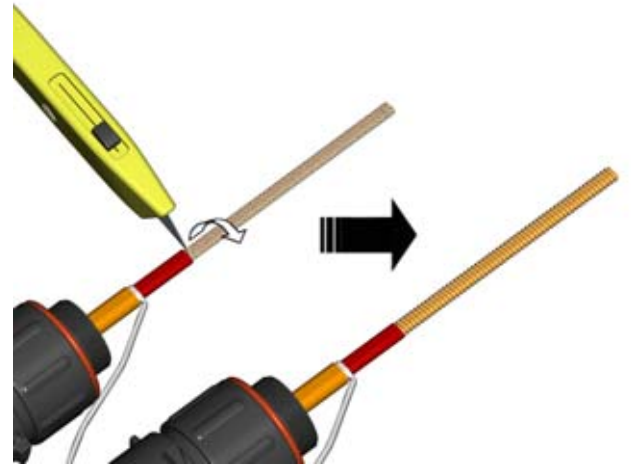

C4. Cut and remove fiberglass braid. Omit this step for FP cable.

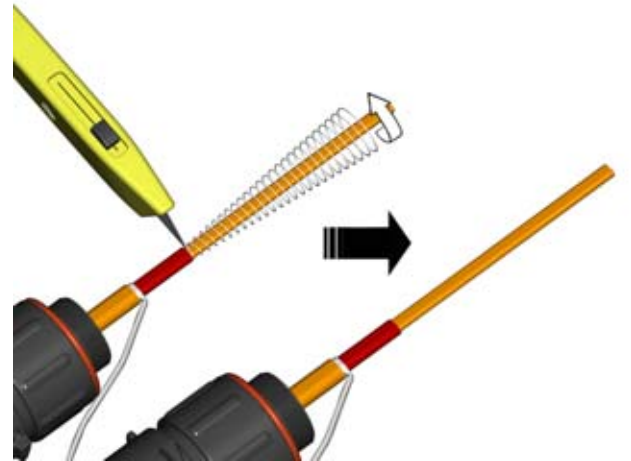

C5. Cut and remove heating element and fiberglass overlay (FP cable only). Push any remaining heating element wire under the primary insulation jacket.

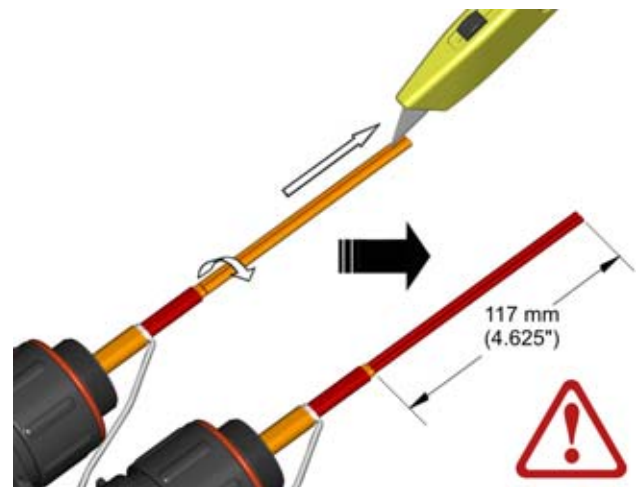

C6. Cut and remove pairing jacket. Do not cut bus wire insulation.

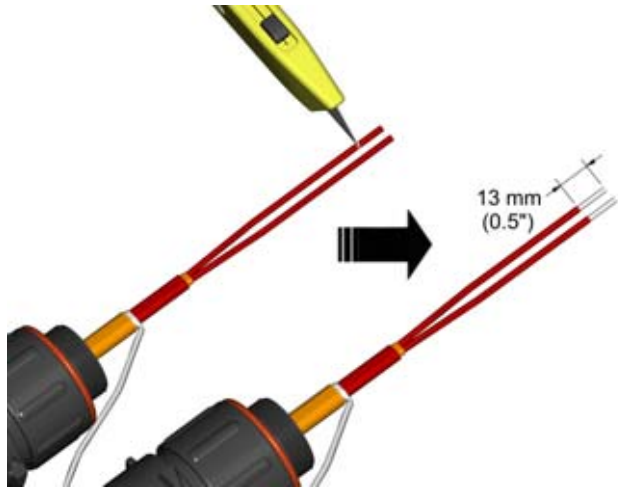

C7. Remove insulation from ends of bus wires.

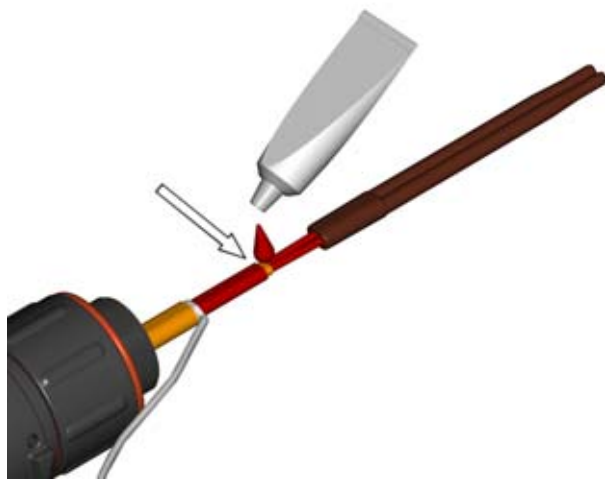

C8. Apply a liberal amount of RTV sealant to cable.

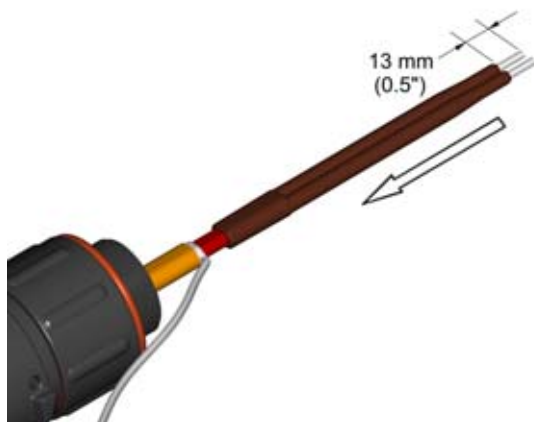

C9. Slide boot onto the end of the cable.

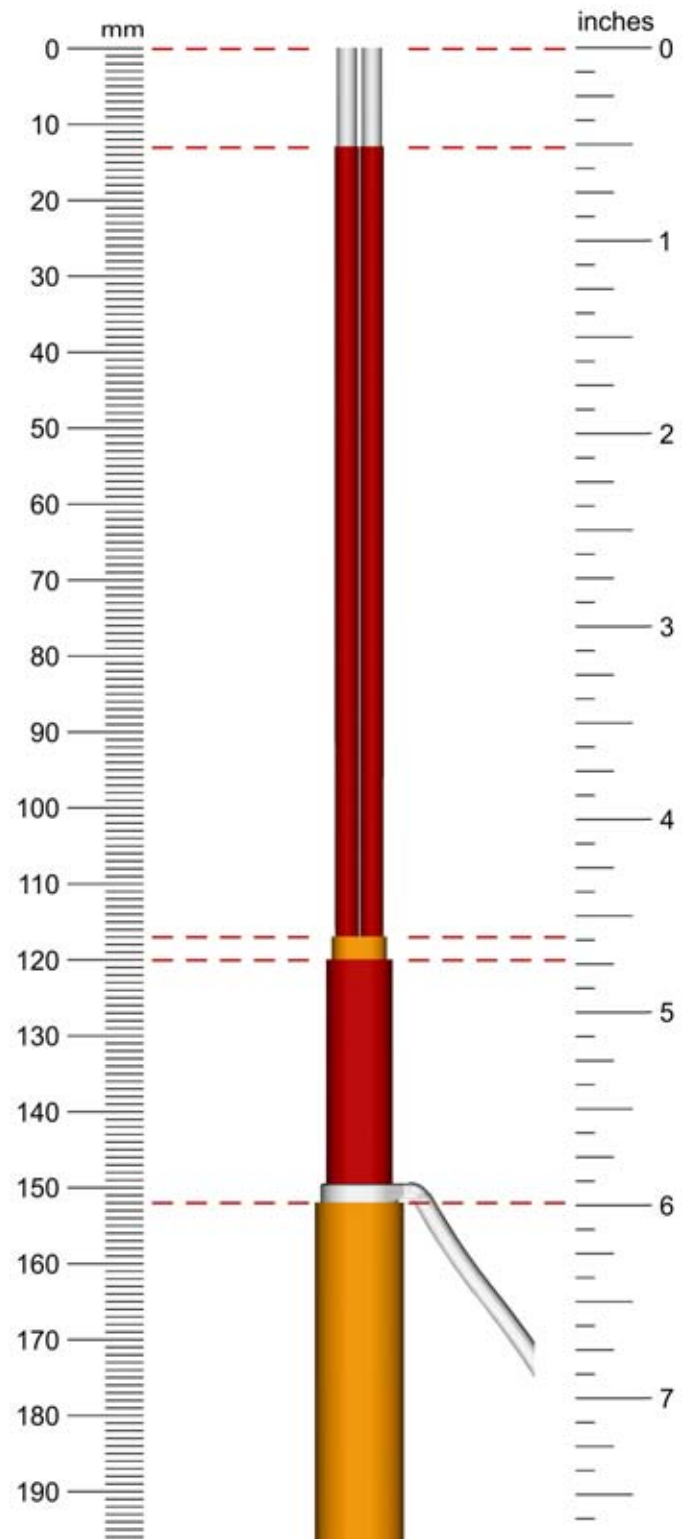

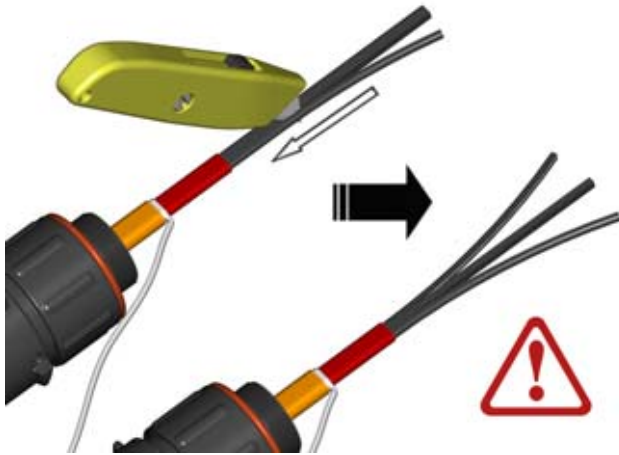

D1. Cut matrix core between inside edges of conductors. Do not cut bus wire strands.

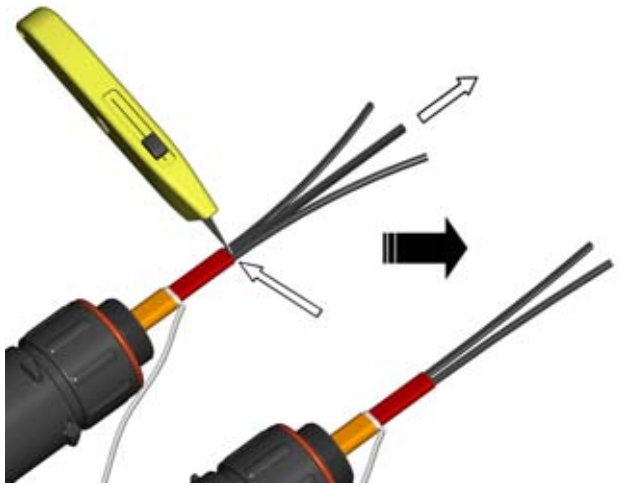

D2. Cut and remove remaining matrix core.

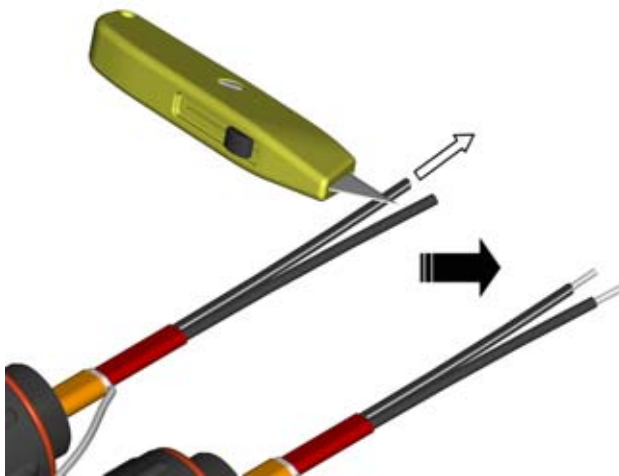

D3. Strip off matrix material at end of conductors.

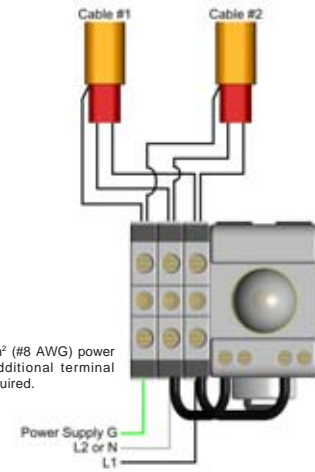

When using 10mm² (#8 AWG) power supply wiring, additional terminal blocks will be required.

E1. Power Connection (1 to 2 Cables)

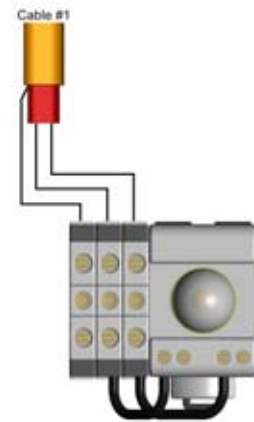

E2. End Termination (1 Cable Only)

Form No. 50809 (04/28/05)



Thermon Manufacturing Company

100 Thermon Drive • P.O. Box 609 • San Marcos, Texas 78667-0609
Phone: (512) 396-5801 • Fax: (512) 396-3627 • 1-800-820-HEAT
www.thermon.com