

# Terminator™ DP

Power Connection Kit for Power Connection,  
In-Line Splice Connection, T-Splice Connection,  
or End Termination Applications

## INSTALLATION PROCEDURES



# Terminator DP

## Receiving, Storing and Handling

1. Inspect materials for damage incurred during shipping.
2. Report damages to the carrier for settlement.
3. Identify parts against the packing list to ensure the proper type and quantity has been received.

## Kit Contents



Item	Quantity	Description
1	1	Expediter Assembly Support Cap with O-Ring Threaded Grommet Compressor Grommet Support Base with O-Ring
2	1	Junction Box Lid
3	1	Junction Box Base with O-Ring
4	1	Nut
5	1	Banding
6	1	Banding Guide
7	1	Terminal Blocks with DIN Rail (Refer to terminal block specifications for maximum allowable wire size)
8	1	Junction Box Cord

## Required: Order Separately for each heater to be fabricated

### PETK Power and End Termination Kits (per heater)

PETK-1D for BSX, RSX, VSX-HT

PETK-2D for KSX, HTSX

PETK-3D for HPT



Item	Quantity	Description
1	1	RTV Sealant Tube
2	1	TBX Power Connection Boot
3	1	ET End Cap
4	1	Tape Strip Teflon 6" (PETK-3D only)
5	1	End Termination Caution Label
6	1	GRW-G Grommet (PETK-3D only)

## Dimensions

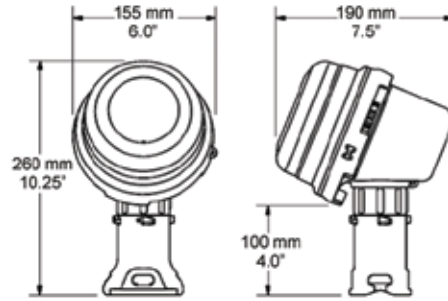

## Installation Precautions

- To minimize the potential for arcing and fire caused by product damage or improper installation use ground-fault protection. The National Electrical Code (NEC) and Canadian Electrical Code (CEC) require ground-fault protection of equipment for each branch circuit supplying electric heat tracing.
- Installation must comply with Thermon requirements and be installed in accordance with the NEC, CEC, or any other applicable national and local codes.
- Component approvals and performance ratings are based on the use of Thermon specified parts only. User supplied power connection fittings must be listed or certified for intended use.
- De-energize all power sources before opening enclosure.
- Keep ends of heating cable and kit components dry before and during installation.
- Individuals installing these products are responsible for complying with all applicable safety and health guidelines. Proper personal protective equipment, or PPE, should be utilized during installation. Contact Thermon if you have any additional questions.

## Certifications/Approvals



IP66/Type 4X -60°C ≤ Ta ≤ +55°C  
Ordinary & Hazardous Locations  
Class I, Division 2, Groups A, B, C, & D, Zone 2 IIC  
Class II, Division 2, Groups F & G, Class III  
Listed Heat Tracing Cable System 137M



## Tools Required

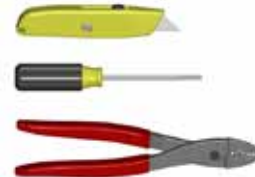

# INSTALLATION PROCEDURES

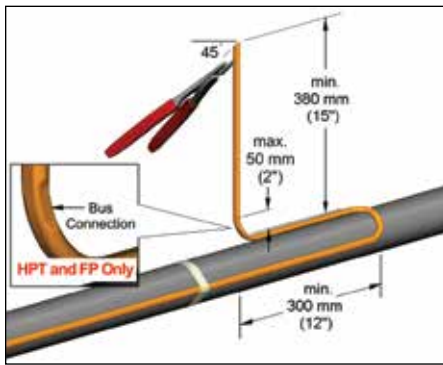

**1a.** For one, two or three cables. Locate bus connection (HPT and FP only) and cable as shown. Cut end of cable at angle to aid in piercing grommet. Leave additional cable for expansion loop.

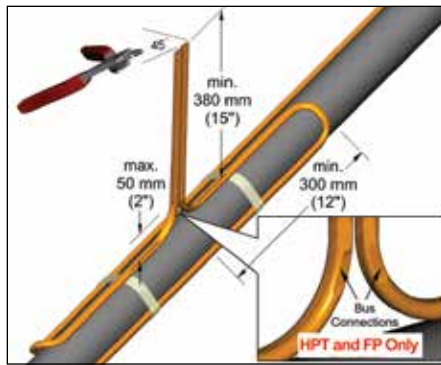

**1b.** Two cables.

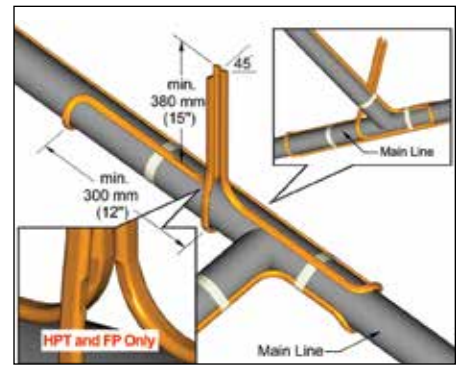

**1c.** Three cables.



**2a.** For one, two or three cables. Insert cable into expediter. If mounted on bottom of pipe, punch out weep hole.



**2b.** Two cables.



**2c.** Three cables.



**3.** Slide expediter toward pipe and route cable through support base entry.



**4.** Insert banding guide into expediter and snap into place.

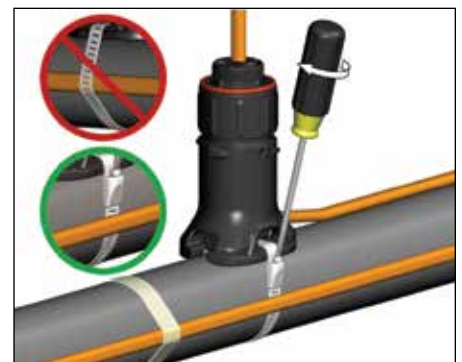

**5.** Mount expediter to pipe using pipe band. Do not band over cable.

# Terminator DP

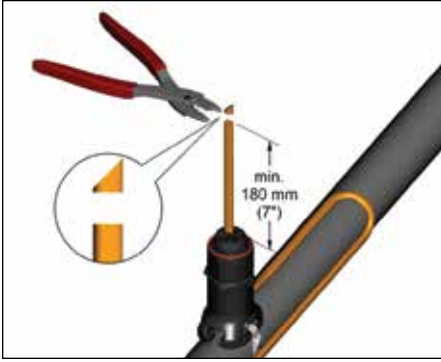

**6.** Cut off end of cable.



**7.** Terminate cable with appropriate PETK termination kit. Refer to PETK installation instructions.

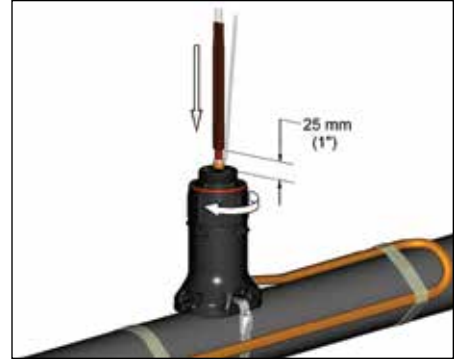

**8.** Push excess cable back through expediter. Tighten cap securely. Tape cable expansion loop to pipe.



**9.** For power connection applications: Use dimple molded into side of junction box base to locate center of hole, drill for user supplied power connection fittings per manufacturer's recommendations.



**10.** Mount junction box base on expediter. Make sure to align slots to properly orient junction box base. Tighten nut securely.



**11.** For power connection applications: Install power connection fittings (user supplied) and pull in power and ground wires.

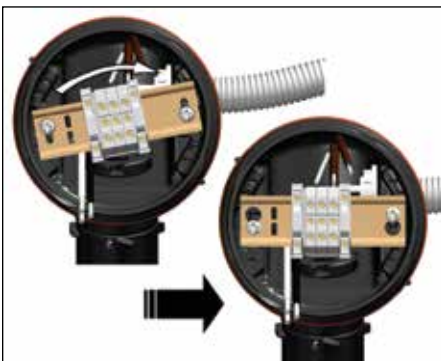

**12.** Install quick mount terminal blocks.



**13.** Complete system wiring. Refer to typical wiring details. Tightening torque 1.5 Nm–1.8 Nm (1.1 ft-lb–1.3 ft-lb).

# INSTALLATION PROCEDURES

## Typical Wiring Details

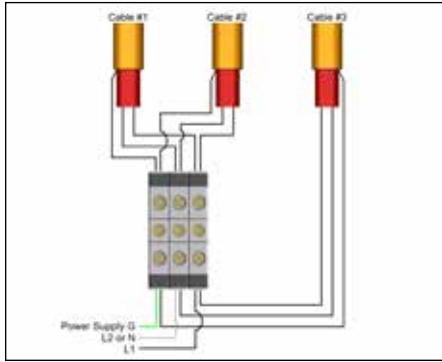

Power Connection (1 to 3 Cables). For 3 cable power connections, additional terminal blocks will be required when using 10 mm<sup>2</sup> (#8 AWG) power supply wiring.

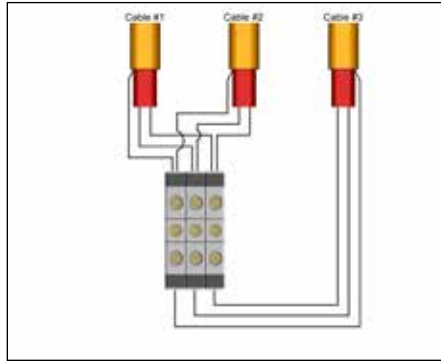

In-Line Splice and T-Splice

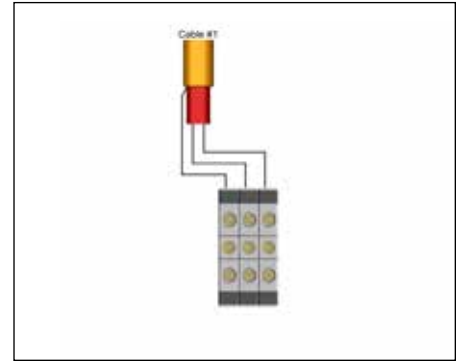

End Termination (1 Cable Only)



**14.** Install junction box lid and twist hand tight. Insert screwdriver into ratchet slots located on side of junction box base.

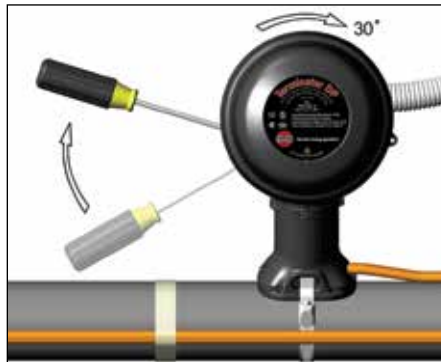

**15.** Use screwdriver to ratchet on junction box lid. Lid will rotate 30 degrees.

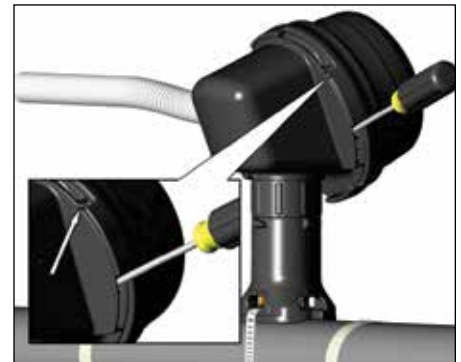

**16.** Lid latch mechanism fully engaged. To remove lid, repeat steps 14 and 15 but in the opposite direction.

