

Terminator™ DE-B Beacon

LED End of Circuit Light Kit

INSTALLATION PROCEDURES



Terminator™ DE-B Beacon

Kit Contents



Item	Quantity	Description
1	1	Expediter Assembly Grommet Compressor Grommet Support Base with O-Ring
2	1	Light Module Cover
3	1	Banding Guide
4	1	Banding (fits 10" pipe and below)
5	1	LED Light Module

Order Separately

SCTK Connection Termination Kits (per cable)

SCTK-1D for BSX, RSX, VSX, VSX-HT

SCTK-2D for KSX, HTSX

SCTK-3D for FP, HPT

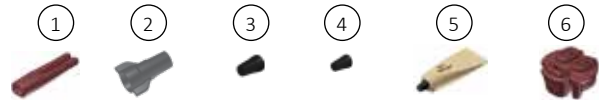

Item	Quantity	Description
1	2	Connection Boots
2	1	Large Wire Nut
3	2	Medium Wire Nuts
4	2	Small Wire Nuts
5	1	RTV Tube
6	1	GRW-G Grommet (SCTK-3D only)

Order Separately

SCTK Terminal Block Connection Kits (per cable)

SCTK-1TB for BSX, RSX, VSX, VSX-HT

SCTK-2TB for KSX, HTSX

SCTK-3TB for FP, HPT



Item	Quantity	Description
1	1	Terminal Block
2	1	Terminal Block Mounting Screw
3	1	Splice Connection Boot
4	1	RTV Tube
5	1	GRW-G Grommet (SCTK-3TB only)

Dimensions

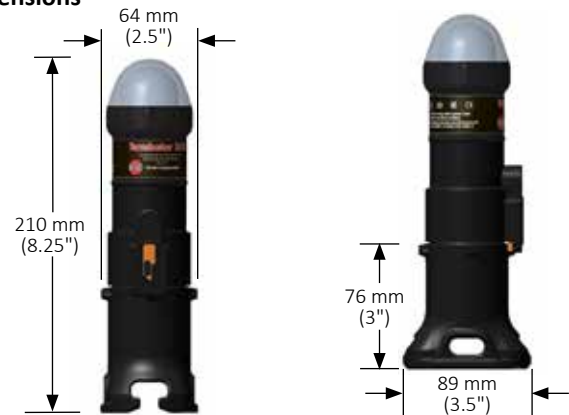

Receiving, Storing and Handling

1. Inspect materials for damage incurred during shipping.
2. Report damages to the carrier for settlement.
3. Identify parts against the packing list to ensure the proper type and quantity has been received.
4. Store in a dry location.

Installation Precautions

- To minimize the potential for arcing and fire caused by product damage or improper installation use ground-fault protection. The National Electrical Code (NEC) and Canadian Electrical Code (CEC) require ground-fault protection of equipment for each branch circuit supplying electric heat tracing.
- Installation must comply with Thermon requirements and be installed in accordance with the NEC, CEC, or any other applicable national and local codes.
- Component approvals and performance ratings are based on the use of Thermon specified parts only. User supplied power connection fittings must be listed or certified for intended use.
- De-energize all power sources before opening enclosure.
- Keep ends of heating cable and kit components dry before and during installation.
- Individuals installing these products are responsible for complying with all applicable safety and health guidelines. Proper personal protective equipment, or PPE, should be utilized during installation. Contact Thermon if you have any additional questions.

Certifications/Approvals



IP66/Type 4X -60°C ≤ Ta ≤ +45°C, T6
-60°C ≤ Ta ≤ +55°C, T5



Ordinary & Hazardous Locations



Class I, Division 2, Groups A, B, C, & D, Zone 2 IIC T6...T5
Class II, Division 2, Groups F & G, Class III

Tools Required



INSTALLATION PROCEDURES

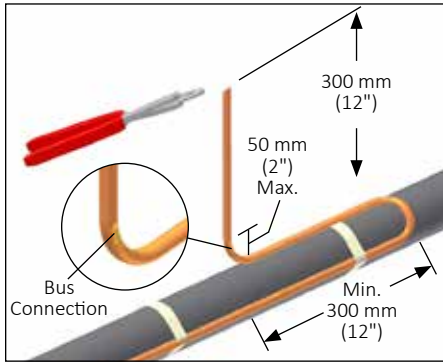

1. Locate bus connection (HPT and FP only) and cable as shown. Cut end of cable at angle to aid in piercing grommet. Leave additional cable for expansion loop.

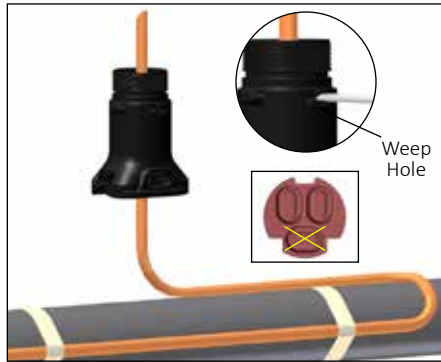

2. Insert cable into expediter. If mounted on bottom of pipe, punch out weep hole.

Note: For HPT and FP cable, exchange grommet in terminator with GR-G provided in PETK-3.

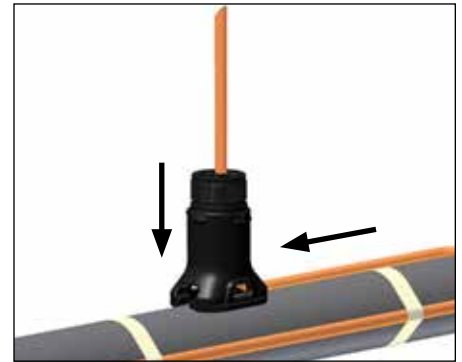

3. Slide expediter toward pipe and route cable through support base entry.



4. Insert banding guide into expediter and snap into place.



5. Mount expediter to pipe using pipe band. Do not band over cable.

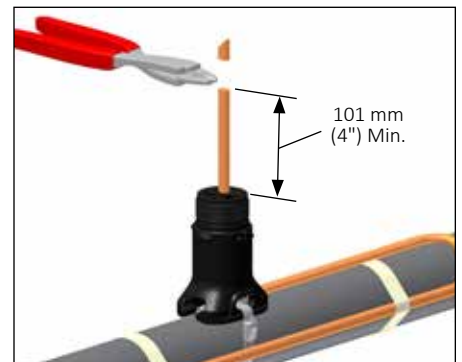

6. Cut off end of cable.

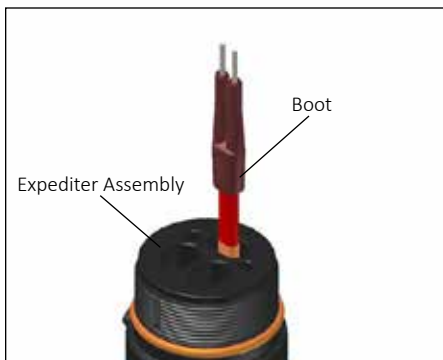

7. Terminate cable with appropriate SCTK termination kit. Refer to SCTK installation instructions. Push excess cable back through expediter. Remove braid pigtail. Tape cable expansion loop to pipe.

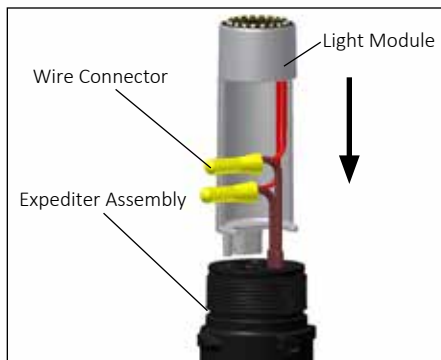

8. When using wire connector: Connect bus wires using small wire nuts (for BSX, HTSX and KSX) or medium wire nuts (for RSX, VSX, VSX-HT, HPT and FP). **When using terminal block:** See steps 9–11. See wiring schematic for connection details.

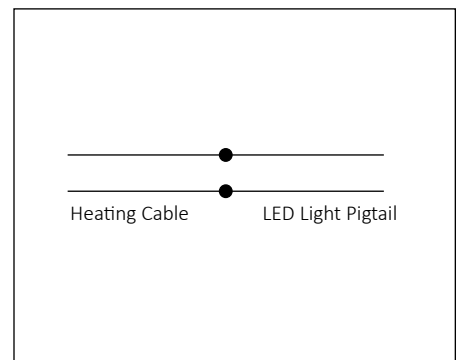

Wiring Schematic for LED Light

Terminator™ DE-B Beacon

INSTALLATION PROCEDURES

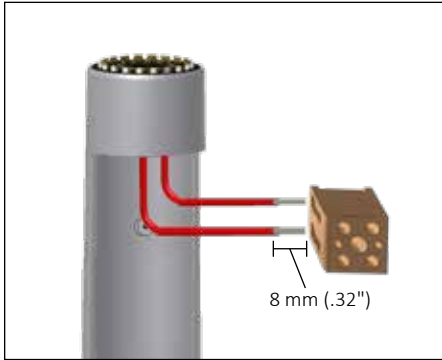

9. When using SCKT-TB Connection Kit, first trim exposed bus wires of the LED pigtail to 8 mm (.32"), then connect to the terminal block.

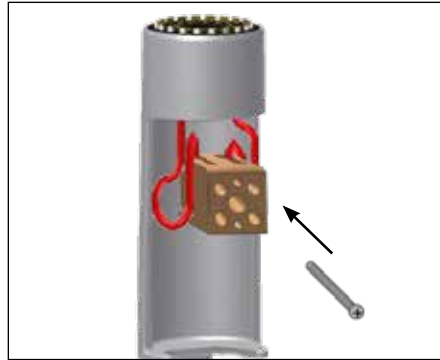

10. Use the terminal block mounting screw to mount terminal block to the LED light module. Bend each pigtail lead around the sides of the terminal block.

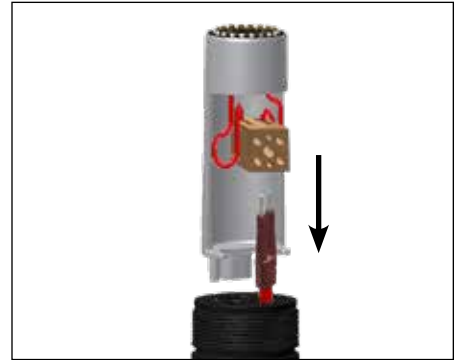

11. Connect the bus wires of the trace heater to the terminal block.

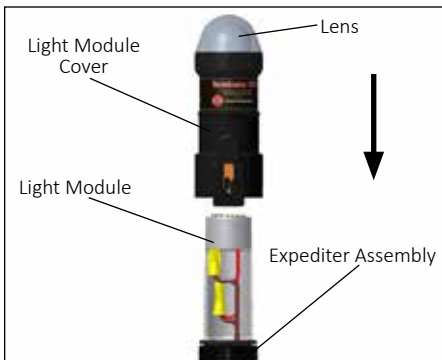

12. Slide the light module cover over light module.



13. Engage threads. Rotate light module cover clockwise and tighten cap securely. Make sure latch mechanism is in the locked position.

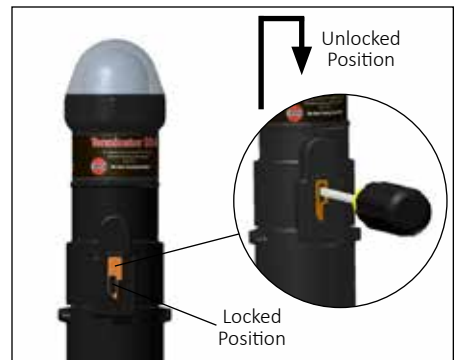

14. To remove cap, de-energize circuit, lift latch mechanism, and unscrew cap.

