

TRACENET™ TCM18

CONTROL AND MONITORING SYSTEM



DATASHEET



TRACENET™ TCM18 CONTROL AND MONITORING SYSTEM

APPLICATION OVERVIEW

Control and monitoring systems play an essential role in heat tracing applications which range from freeze protecting water lines to maintaining critical process temperatures. While mechanical thermostats have been used successfully for many heat tracing applications, a more complete control and monitoring solution is necessary for most industrial heat tracing applications. Advancements in microprocessor-based technology have made electronic control and monitoring units both cost effective and reliable. Electronic control and monitoring systems ensure accurate temperature measurements, conserve energy and extend system life.

A versatile electric heat tracing control and monitoring network is key to reducing operating cost in plants. Research has shown that the following features are a prerequisite within many industrial heat tracing applications:

- Monitor electric heat trace circuit operating and ground/earth leakage currents
- Selectable control method (On/Off, On/Off With Soft Start, Proportional, Ambient Proportional) on a per circuit basis
- Programmable alarm set points, with alarm acknowledgment and reset capability
- Programmable trip set-points for each circuit
- Temperature sensor status indication
- Unique circuit identifier
- Communication to host computer via RS485 serial communication.
- "Push to Test" ground/earth leakage test feature on a per circuit basis
- Ground/earth leakage interruption capability

Note:

1. For equipment in explosive atmospheres, to avoid electrostatic discharge, clean the viewing window with a damp cloth only. If the equipment is not installed and operated within the specifications and limitations indicated by Therman, then the protection provided by the equipment may be voided.

TRACENET TCM18 SYSTEM SPECIFICATIONS

Environmental:

Hazardous Locations,

- Indoor and Outdoor - Solid State Relays

Ordinary Locations,

- Indoor and Outdoor - Power Distribution and Mechanical Relays and/or Solid State Relays

Operating Ambient Range: -40°C (-40°F) to 55°C (131°F)

Enclosures: Type 4, 4X, IP54 *

TraceNet Supply Voltage: 100-240 Vac, 50/60 Hz

Heat Tracing Voltages: 100-600 Vac

User Interface: 44 mm (1-3/4") x 127 mm (5") backlit LCD display

Maximum Number of Circuits: 72 within one TC series control panel

Temperature Sensors per Circuit: One or Two 100 W Platinum, 3-wire RTD's

Current Switching Devices:

Solid State Relay **:

1-pole up to 30 Amps

2-pole up to 15 Amps per pole

Mechanical Relay:

Per design requirements

Control Methods:

Process Sensing:

On/Off, On/Off With Soft Start, Proportional

Ambient Sensing:

On/Off, On/Off With Soft Start, Ambient Proportional (APC)

Control Temperature Range: -129°C (-200°F) to 600°C (1112°F)

Alarm Settings (per circuit):

Low/High Temperature

Low/High Current

High Ground/Earth Leakage Current

RTD and Relay Faults

Loss of Communication

Secondary Alarm Settings (with trip option):

High Temperature, High Heater Current,

Ground / Earth Leakage Current

Communications:

Dual RS 485

Ethernet/Bluetooth/Wireless (requires optional communication module)

Auxiliary Output Power: 24 Vdc at 0.5 Amp

External Alarm Relays:

24 Vdc/Vac @ 0.5A or 100-240 Vac @ 0.5A

Two, solid state rated at 350 mA (24 Vdc) per PM6

* Additional panel types are available. Contact Therman for details.

** Rating based on heat sinks installed external to panel. Relay ratings have a reduced rating when sinks are used internal to panel. Multiple single pole relays may be used for phase to phase and three phase circuits. Higher voltage rating relays are also available as an option.

TCM18 PANEL CERTIFICATIONS/APPROVALS¹

TraceNet systems are approved/certified for installation and operation in Ordinary and Class I Div 2 Groups B, C, D, and Ex hazardous (classified) locations.



TYPICAL THERMON TRACENET TCM18 SYSTEM

(See Page Numbers Listed Below for Additional Information on Each Component)



TRACENET™ TCM18 CONTROL AND MONITORING SYSTEM

TCM18 CONTROL AND MONITORING MODULE

The TCM18 is a multicircuit microprocessor-based temperature control and monitoring module developed specifically for heat tracing. This module provides control and monitoring capabilities via digital information display for a maximum of eighteen heat trace circuits. This module can be configured for either process sensing control (with either one or two RTD inputs for each circuit) and/or ambient sensing control (with the option of one or two RTD inputs).

The TCM18 provides circuit information and programming capability through the LCD digital display and a dedicated touchpad on the front of each module.



TCM18 COMMUNICATION

The TCM18 has two RS485 ports which communicate via Modbus ASCII or RTU protocol. One port can communicate to TraceView Network Explorer or to compatible DCS system. The second port is provided for an auxiliary RS485 communication to an optional Ethernet or wireless communication module.

TCM18 RATINGS/SPECIFICATIONS

Control and monitoring capacity.....18 heat tracing circuits
 Nominal module supply voltage.....120-240 Vac 50/60Hz
 Input current.....1.5 Amp max.
 Power consumption.....70 watts
 Minimum ambient temperature.....-40°C
 Storage ambient temperature-40°C to 85°C
 Data retention non-volatile EEPROM
 Power clamp function.... programmable from 20% to 100%
 Temperature input.... up to 36 3-wire platinum 100 Ω RTDs
 Temperature control range.....-129°C to 600°C
 Control band... programmable in increments of 1 degree
 High operating current alarm and trips..... 0.1 to 100 Amps
 Low operating current alarm.....0.1 to 100 Amps
 Ground leakage alarm and trips..... 20 to 225 mA
 (in 1 mA increments)

Alarm relays

Three sealed dry contacts, rated @ 0.4-amps resistive at 24 Vdc/Vac

Auxiliary output power..... 24 Vdc at 0.5 Amps
 Self-test frequency..... programmable from 2 to 99 hours
 Communication.... Modbus ASCII/RTU via Dual RS 485 ports
 Communication rate up to 57600 Baud
 Certifications.....ATEX
 Pollution category 2

TCM18 PRODUCT FEATURES

- Module operates in a wide range of ambient conditions.
- Each heat tracing circuit allows input from single or dual RTD inputs.
- User friendly four line heated LCD display for circuit and alarm information with input from a dedicated touchpad.
- Conformally coated electronics for use in panels in indoor and outdoor locations.
- Low and high temperature alarm and additional programmable high temperature trip functions.
- Low and high heater current alarm and trip functions.
- High ground/earth leakage current alarm and trip functions
- Internal test functions for ground/earth leakage functionality.
- Includes On-Off, On-Off with Soft Start, Proportional, and APC (Ambient Proportional Control) modes.
- Auxiliary 24 Vdc output for powering optional communication modules or other auxiliary devices.
- Equipment has been evaluated and found suitable for Overvoltage Category II over the stated range of module supply voltage, in accordance with IEC-61010-1:2010.

TCM18 CONNECTION PORTS

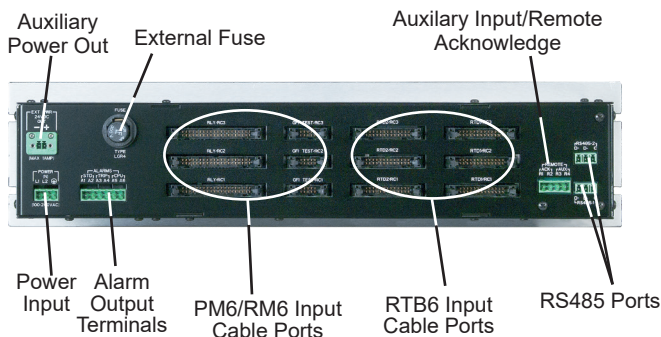

TCM18 DIMENSIONAL DATA

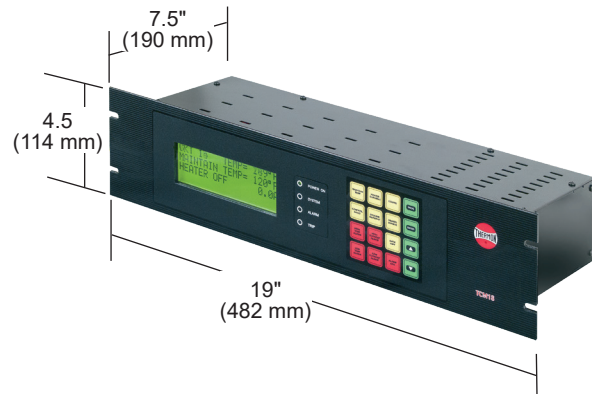

PM6 POWER MODULE

The PM6 serves as the power switching module, using solid state relays and links the heat tracing power circuit to the TCM18 control and monitoring module via ribbon cable.

PM6 PRODUCT FEATURES

- Operates in a wide range of ambient conditions.
- Single or dual pole solid state switching.
- Nickel plated terminal construction.
- Black anodized aluminum heat sink capable of dissipating the heat generated for up to a total of 180 Amps continuous.
- Standardly supplied with polycarbonate touch safe cover for increased operator touch safety.
- Includes a ground/earth leakage circuit test loop which allows the operator to conduct a functionality test on each circuit.
- Measures ground/earth leakage and heater operating currents.

PM6 COMPONENT SPECIFICATIONS

Circuit control capacity up to six heat trace circuits
 Single pole relay switching capacity 30 Amps at 240 Vac*
 Dual pole relay switching capacity 15 Amps at 240 Vac*
 Relay power connection 40-Pin header ribbon cable
 Ground/earth leakage test connection
 10-Pin header ribbon cable
 Maximum storage temperature 85°C (185°F)
 Minimum storage temperature -40°C (-40°F)
 Operating ambient temperature range
 -40°C (-40°F) to 70°C (158°F)
 Power terminal connections
 20 to 6 AWG (0.5 to 10 mm²), 630 Vac
 Printed circuit board conformally coated
 Alarm two 24 Vdc @ 350 mA each

* Rating based on heat sinks installed external to panel. Relay ratings have a reduced rating when sinks are used internal to panel. Higher voltage rating relays are also available as an option.

PM6 DIMENSIONAL DATA

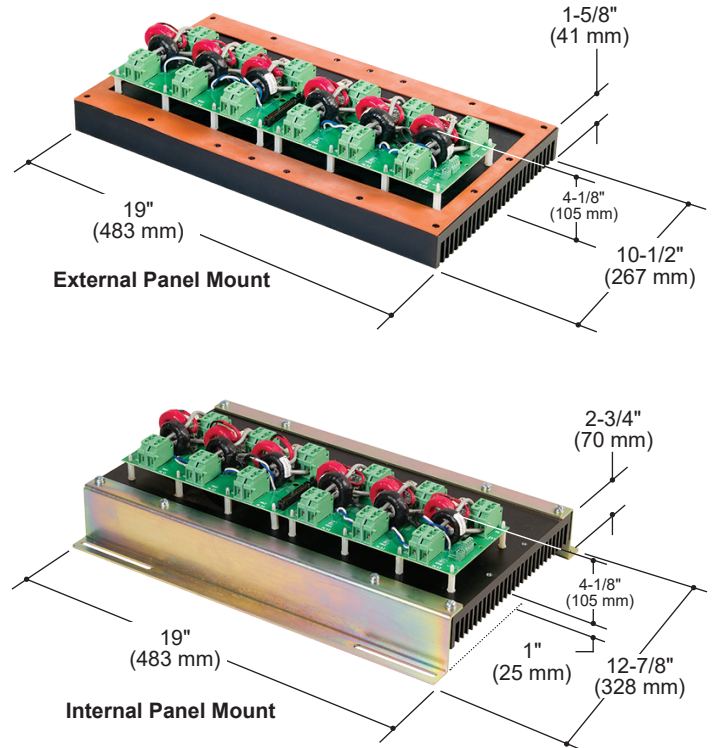

PM6 CONNECTION DIAGRAM

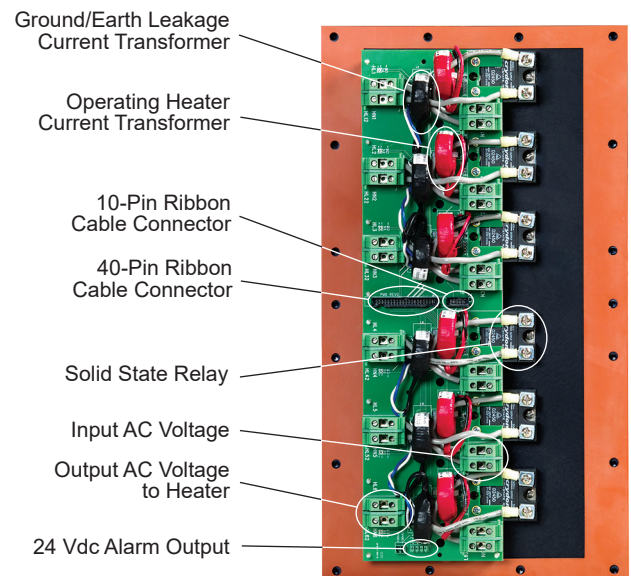

TRACENET™ TCM18 CONTROL AND MONITORING SYSTEM

RTB6 RTD INTERFACE MODULE

The RTB6 is a DIN rail mountable six RTD sensor input module which links the field RTD wiring to the TCM18 control and monitoring module via ribbon cable.

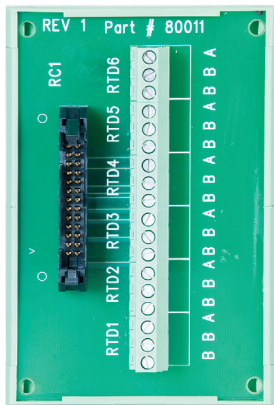

RTB6 DIMENSIONAL DATA

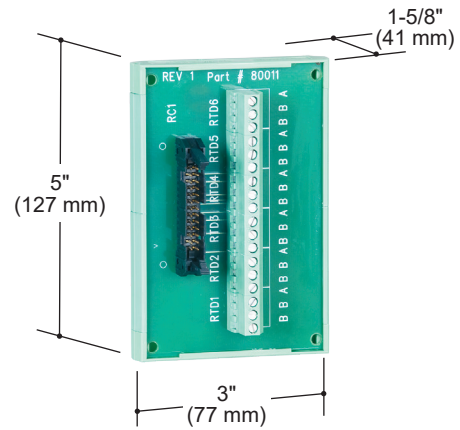

RTB6 PRODUCT FEATURES

- Operates in a wide range of ambient conditions.
- DIN rail mountable.
- Conformally coated printed circuit board for use in panels located in indoor and outdoor environments.

RTB6 COMPONENT SPECIFICATIONS

Maximum storage temperature.....	185°F (85°C)
Minimum storage temperature.....	-40°F (-40°C)
Oper. ambient temp. range.....	-40°F (-40°C) to 158°F (70°C)
Terminal connections.....	28-12 Awg (up to 2.5 mm ²)
Maximum RTD capacity.....	6

RTB6 CONNECTION DIAGRAM

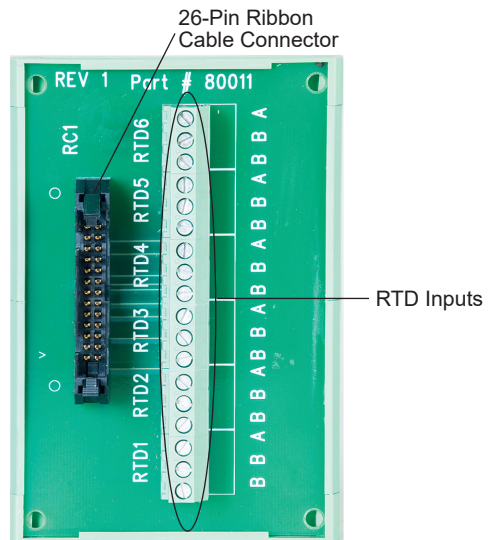

RM6 RELAY INTERFACE MODULE

The RM6 is a DIN rail mountable six circuit relay interface module for linking individual solid state or mechanical relays via ribbon cable to the TCM18 module. The RM6 comes with individual terminal strips which allow the interconnection of individually mounted ground/earth leakage and heater operating current sensing transformers as well as the ground/earth leakage circuit fault test loop.

RM6 PRODUCT FEATURES

- Operates in a wide range of ambient conditions.
- DIN rail mountable.
- Conformally coated printed circuit board for use in panels located in indoor and outdoor environments.

RM6 COMPONENT SPECIFICATIONS

Maximum storage temperature.....185°F (85°C)
 Minimum storage temperature.....-40°F (-40°C)
 Oper. ambient temp. range.....-40°F (-40°C) to 158°F (70°C)
 Terminal connections..... 28-12 Awg (up to 2.5 mm²)
 Earth leakage test connection.....10-Pin header ribbon cable
 Relay connection..... 40-Pin header ribbon cable

RM6 DIMENSIONAL DATA

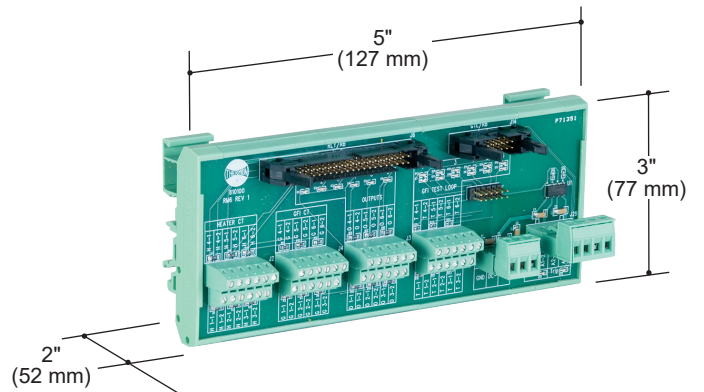

RM6 CONNECTION DIAGRAM

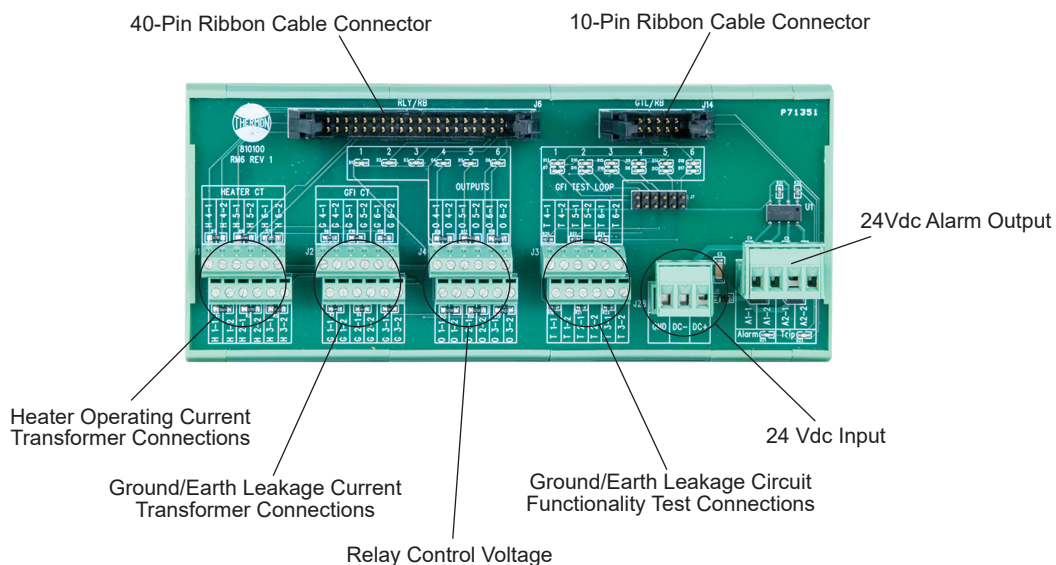

TRACENET™ TCM18 CONTROL AND MONITORING SYSTEM

TRACENET TVNE

The TCM18 communicates via Modbus RTU or ASCII protocol through its RS485 ports at programmable rates up to 57600 Baud to the Theron TVNE electric tracing circuit monitoring software. TVNE provides centralized electric tracing information such as:

- Heat tracing circuit status
- Temperatures, heater operating and earth/ground current alarm/trip events
- Event history
- Data trending
- Maintenance and troubleshooting guidance

TVNE additionally provides the operator the ability to:

- Change set points as well as alarm and trip values
- Reconfigure system control parameters
- Provide heat tracing management reports
- Load shed circuits on a priority level basis
- View up to ten (10) files (.dwg or .pdf) for isometric drawings, sketches, and/or identifying photos as well as operator notes fore each controller circuit.

DCS COMMUNICATIONS

The TCM18 can also communicate via Modbus RTU or ASCII protocol through its RS485 ports at programmable rates up to 57600 Baud to the plant DCS. The same operating data and control capabilities that are available through TVNE are also accessible in the plant control room at the DCS.



PRODUCT REFERENCE LEGEND

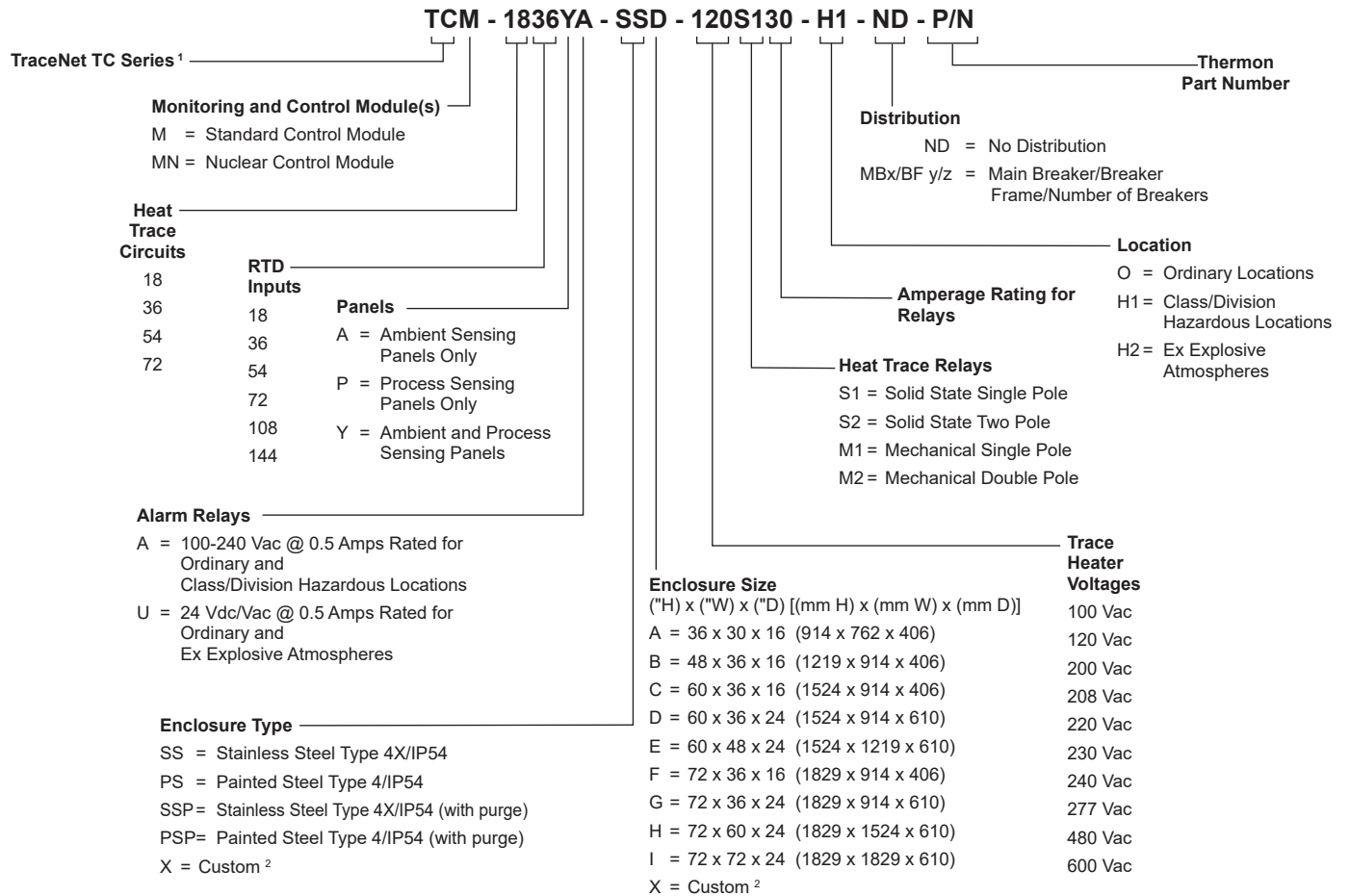

Notes:

1. Other accessory modules from the TraceNet TN Series, such as the TSM1/ TSM1L and PS70, may be available for use in TC Series panels. Contact the manufacturer for details.
2. Contact Thermon for additional information.



Corporate Headquarters: 7171 Southwest Parkway • Building 300, Suite 200 • Austin, TX 78735 • Phone: 512-690-0600
For the Thermon office nearest you visit us at . . . www.thermon.com

Form TEP0131-1021 © Thermon, Inc. • Printed in U.S.A. • Information subject to change.

