



PRODUCT SPECIFICATIONS

T-802 HEAT TRANSFER COMPOUNDS

APPLICATION

T-802 is a two-part medium temperature resin-based heat transfer compound for use in moist and/or corrosive environments. Thermon's heat transfer compounds provide an efficient thermal connection between the tracer and the process equipment. By eliminating the air voids that would ordinarily exist, heat is directed into the pipe wall primarily through conduction rather than convection and radiation. A single tracer utilizing Thermon's heat transfer compound has the equivalent performance of three to five air convection (bare) tracers.

T-802 is typically utilized for applications requiring relatively short curing times where steam is not currently available. T-802 begins curing upon mixing. Curing times vary from 1.25 to 4 hours depending on mixing ratios and ambient temperatures.

SPECIFICATIONS/RATINGS

Container sizes

- T-802-Q 1-quart (0.946-liter) cans
- T-802-G 1-gallon (3.79-liter) cans
- Maximum exposure temperature.....275°F (135°C)
- Minimum exposure temperature..... -320°F (-196°C)
- Minimum installation temperature.....32°F (0°C)
- Heat transfer coefficient, Utracer to pipe wall
20-40 Btu/hr•F•ft² (114-227 w/m²•°C)
- Electrical resistivity 146 ohms/inch (57 ohms/cm)
- Shelf life..... 1 year (unmixed)
- Bond shear 1,000 lbs/in² (6,895 kPa)
- Water-soluble no



DESCRIPTION

T-802 is available in 1-quart (0.946-liter) and 1-gallon (3.79-liter) cans.

BENEFITS

- Nonsoluble in water
- Self-curing—no heat required
- Epoxy resin base creates strong thermal and mechanical bond
- Suitable for moist and/or corrosive environments
- Free design assistance

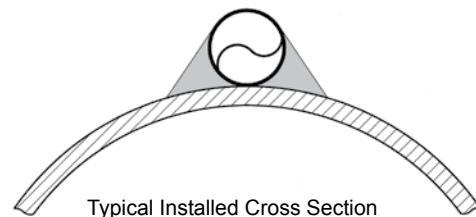

Typical Installed Cross Section
(Fillet application)

THERMON The Heat Tracing Specialists®

ISO 9001
REGISTERED

Corporate Headquarters: 100 Thermon Dr • PO Box 609 San Marcos, • TX 78667-0609 • Phone: 512-396-5801 • 1-800-820-4328
For the Thermon office nearest you visit us at . . . www.thermon.com

Form TSP0017-1014 • © Thermon Manufacturing Co. • Printed in U.S.A. • Information subject to change.



TYPICAL STEAM TRACING SYSTEM

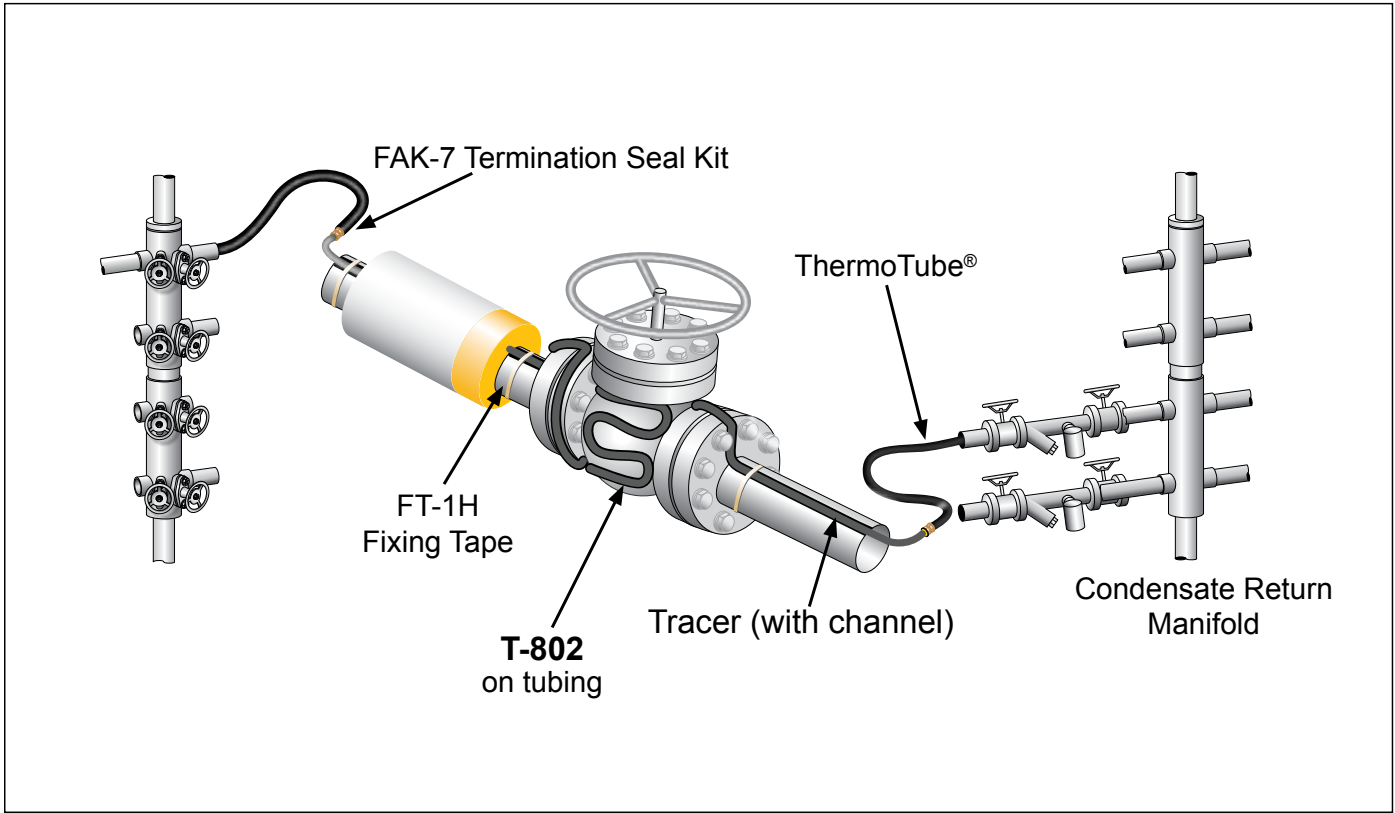

PRODUCT CONFIGURATIONS

Catalog Number	Description	Max. Exposure Temperature
T-802-Q	1-Quart 2-Part Compound*	275°F (135°C)
T-802-G	1-Gallon 2-Part Compound*	275°F (135°C)

* Shipped in two (2) separate containers.



Stainless Steel Banding used to secure tracer to piping.

- **T2SSB** (.50" x .020") for 3/8" and 1/2" O.D. tube tracers.
- **T3SSB** (.50" x .030") for 3/4" and 1" O.D. tube tracers and NPS pipe tracers.
- **C001** banding tool for applying tension to T2SSB or T3SSB banding.



1950A crimping tool for T34PB-CR seals.

T34PB-CR crimp seals for fastening tensioned banding.