



Flammability Testing

UL 94, "The Standard for Flammability of Plastic Materials for Parts in Devices and Appliances", is one of the most widely accepted flammability performance standards for plastic material's. This standard determines a materials ability to propagate or extinguish a flame once ignited. According to UL, this standard has been harmonized with IEC 60707, 60695-11-10 and 60695-11-20 and ISO 9772 and 9773.



There are twelve (12) flame classifications specified in UL 94. The classifications are used to describe materials burning characteristics after test specimens have been exposed to a specified test flame under controlled laboratory conditions. The classifications relate to rate of burning, time to extinguish, ability to resist dripping, and whether or not the drips are burning.

Six (6) of the classifications relate to commonly used materials in enclosures, structural parts, and insulators. Listed in descending order of flammability, the classifications are:

- 5VA Afterflame or afterglow time ≤ 60 seconds after 5th flame application, specimen may not have a burn-through
- 5VB Afterflame or afterglow time ≤ 60 seconds after 5th flame application, specimen may have a burn-through
- V-0 burning stops within 10 seconds, no drips allowed
- V-1 burning stops within 30 seconds, no drips allowed
- V-2 burning stops within 30 seconds, drips or flaming particles allowed
- HB slow burning on a horizontal specimen less than 76 mm/min for thickness less than 3mm.

The next three classifications are a result of the "Thin Material Vertical Burning Test". This test is for thin materials that are not capable of supporting themselves in a horizontal position. For example, substrates used on flexible printed circuit boards. The classifications are:

- VTM-0 Afterflame $\leq 10s$, afterglow $\leq 30s$, no dripping
- VTM-1 Afterflame $\leq 30s$, afterglow $\leq 60s$, no dripping
- VTM-2 Afterflame $\leq 30s$, afterglow $\leq 60s$, dripping allowed

Finally, the last three classifications are for horizontal burning of foamed material. Materials may be classified as follows:

- HF-1 Afterflame $\leq 2s$, afterglow $\leq 30s$, no dripping
- HF-2 Afterflame $\leq 3s$, afterglow $\leq 30s$, dripping allowed
- HBF burning rate not exceeding 40mm/min

Depending on the specifications of the test method, specimens molded from plastic material are oriented in the horizontal or vertical position. They are subjected to

a flame ignition source for a specified period of time. Some test specifications require the flame applied only once while others require multiple exposures.

Materials with an HB rating were tested in the horizontal position and found to burn at a rate less than the specified maximum. HB classified materials are generally not permitted where flammability is a major concern.

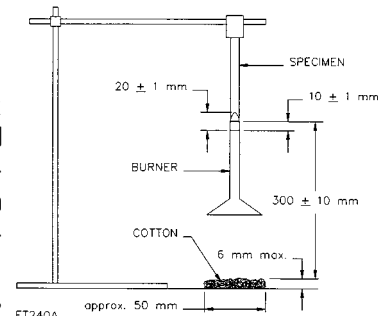

The "V" ratings indicate the material was tested in a vertical position. V-0, V-1, and V-2 indicate that the material self-extinguished within a specified time period after the flame was removed and whether the test specimen dripped flaming particles that ignited a cotton indicator below the sample. VTM ratings are derived from tests designed for very thin materials. 5V ratings are the result of the most severe tests where the flame was applied 5 times.

CSA Flammability

The Canadian Standard Association flammability test C22.2 No 0.6, Test A is similar to UL 94 5V test. However, the tests are more severe. The flame is applied for longer durations and the specimens must extinguish in less time. Results of this test are considered in compliance with UL 94.

ASTM D 2863 (ISO 4589)

A limited oxygen index (LOI) is assigned to specimens when tested in accordance with ASTM D 2863, "Measuring the Minimum Oxygen Concentration to Support Candle-Like Combustion of Plastics". Specimens are burned in a laboratory controlled mixture of nitrogen and oxygen. The oxygen index represents the minimum amount of oxygen that must be present to sustain flame on a thermoplastic material. LOI is defined as the minimum oxygen concentration where the material will burn for three minutes or keep a sample burning over a distance of 50 mm. The higher the LOI, the less likely the material will burn.

