

# TraceNet™ ECM/FAK-9

Temperature Sensor Location  
when using  
FAK-9 Bulkhead Entry Heat Shrink  
for use with TubeTrace™ Bundles

## INSTALLATION PROCEDURES

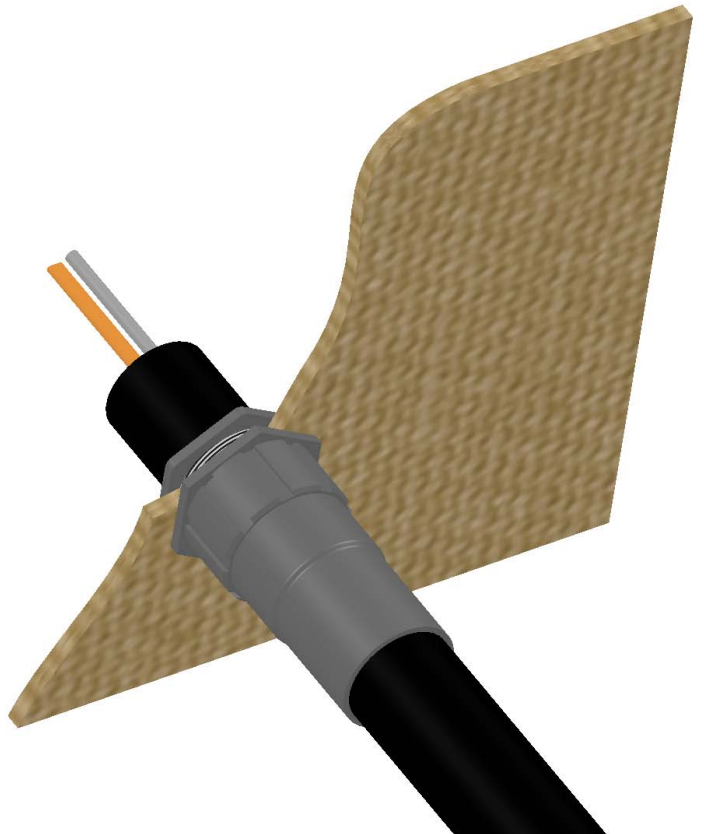

# TraceNet™ ECM/FAK-9

The Terminator ECM/FAK-9 Entry Kit is designed to provide accurate control with ECM Electronic Control and make a waterproof seal over the end of TubeTrace and terminate Thermon electric heat trace in an approved Terminator junction box. Review instructions prior to installation. Kit will make one connection.

## Receiving, Storing and Handling

1. Upon receiving, check to make sure the proper type has been received.
2. Inspect for any damage incurred during shipping.
3. Report all damages to the carrier for settlement.
4. Identify parts against the packing list to ensure the proper type and quantity has been received.
5. Store in a dry location.

## TraceNet ECM Kit Contents (Order Separately)



## FAK-9 Kit Contents (Order Separately)

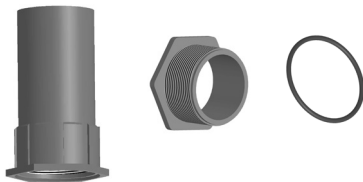

## FAK-7 Kit Contents (Order Separately)

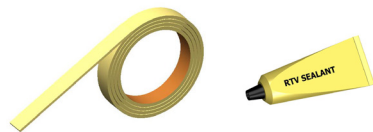

## PT-100 (Order Separately)



## FAK-9: Sizing and Selection Chart

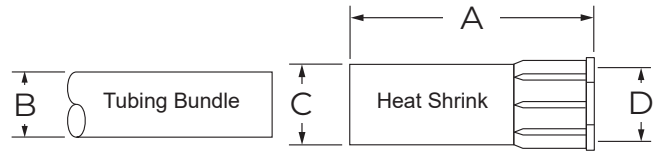

Catalog No.	A Overall Nom. Length mm (inch)	B TubeTrace Max. O.D. mm (inch)	C I.D. After Shrinkage mm (inch)	D Drill Size mm (inch)	Maximum Exposure Temp. °C (°F)
<b>FAK-9S</b>	101.6 (4)	40.6 (1.6)	19 (.75)	51.0 (2)	135 (275)
<b>FAK-9</b>	152.4 (6)	53.3 (2.1)	19 (.75)	60.325 (2.375)	135 (275)
<b>FAK-9L</b>	177.8 (7)	73.4 (2.9)	36.3 (1.43)	89 (3.5)	135 (275)
<b>FAK-9LX</b>	292.1 (11.5)	95 (3.75)	38.1 (1.5)	115 (4.5)	135 (275)

## Installation Precautions

- Keep ends of tube bundles, heat tracing and kit components dry before and during installation.
- For SE/ME electrically heated tubing, de-energize all power sources before addressing circuit termination and power connection.
- Component approvals and performance ratings are based on the use of Thermon specified parts only. User supplied power connection fittings must be listed or certified for intended use.
- To minimize any risk of arcing in TubeTrace SE/ME bundles, the National Electrical Code (NEC) and Canadian Electrical Code (CEC) require ground-fault protection of equipment for each branch circuit supplying electric heat tracing.
- Installation must comply with Thermon requirements and be installed in accordance with all applicable national and local codes.
- Individuals installing these products are responsible for complying with all applicable safety and health guidelines. Proper Personal Protective Equipment (PPE) should be utilized during installation. For additional information, contact Thermon.

## Tools Required

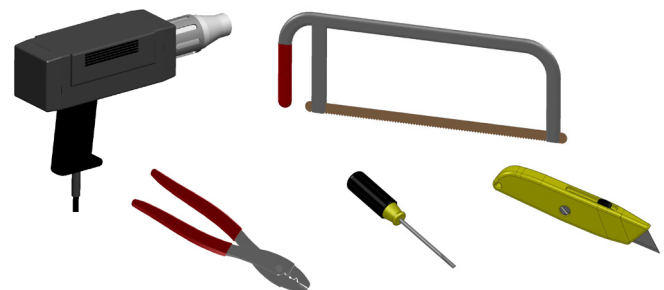

## Terminator ECM Certifications/Approvals

CE Ex II 2 (2) G Ex eb mb [ib] IIC T4, Ex tb IIIC T135°C SIR A 12ATEX5239X  
II 2 (2) D Ex tb IIIC T135°C IP66 Db

IEC IECEx International Electrotechnical Commission  
IEC Certification Scheme for Explosive Atmospheres  
SIR 12.0103X

# INSTALLATION PROCEDURES

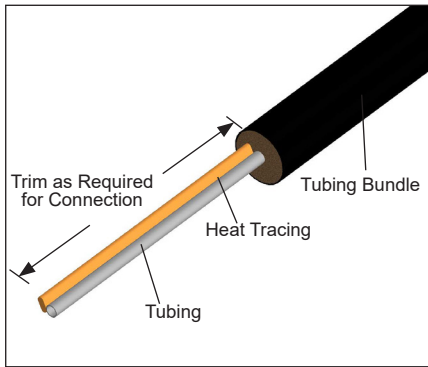

1. Remove outer jacket and insulation from tubing bundle to expose the electric heat trace and tubing. Ensure sufficient heat trace is available for electrical connection. See instructions included with heat trace PETK kit.

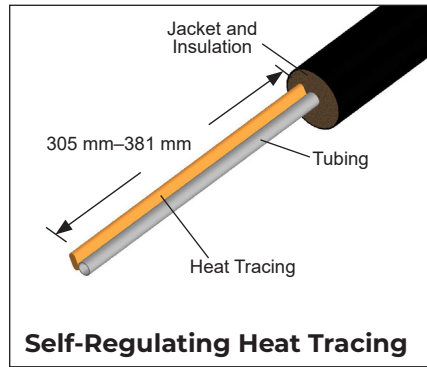

**Self-Regulating Heat Tracing**

2. Trim heat tracing to within 305 mm–381 mm of the end of the insulation. If self-regulating heat trace proceed to step 3. For Zone-type heat trace continue with identification of bus connection on step 2a.

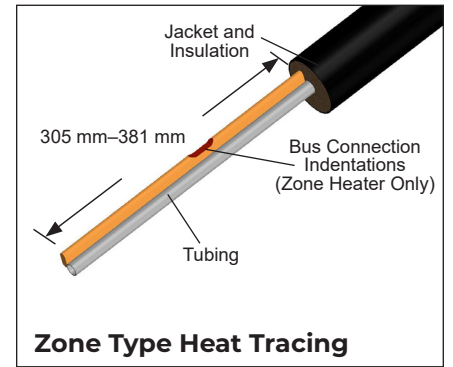

**Zone Type Heat Tracing**

- 2a. Strip back bundle insulation 38 mm to 76 mm beyond bus connection heat tracing. If bus connection indentation is less than 305 mm–381 mm from end of the heat tracing, proceed stripping the bundle insulation to the next indentation.

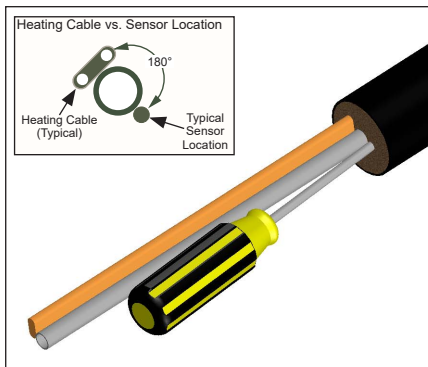

3. Prepare tubing bundle for PT100 sensor by inserting a phillips screwdriver a minimum depth of 150 mm (6") between the process tube(s) and insulation at a point opposite the heating cable. The sensor should be placed 180° around the circumference from the heating cable. Make sure that the entire length of the sensor is in intimate contact with the tube surface. Prevent kinking.

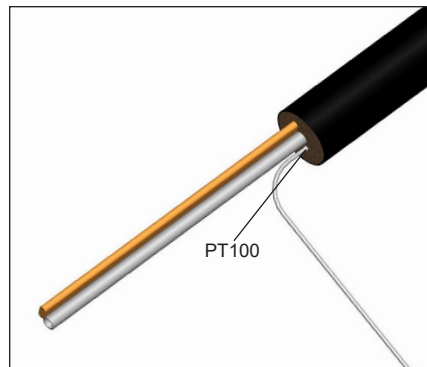

4. Insert the PT100 (150 mm) into the prepared hole, between the tube(s) and the thermal insulation.

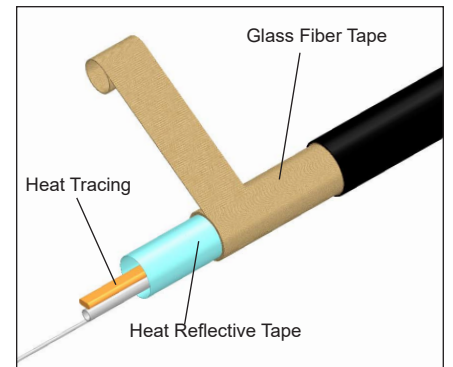

5. Wrap tubes and heat tracing with pass of heat reflective tape (25% overlap). Then wrap with 3 passes of glass fiber tape (50% overlap), or until fiber tape is equal to original bundle insulation thickness. See steps 9, 10, and 11 for bundle end seal using FAK-7.

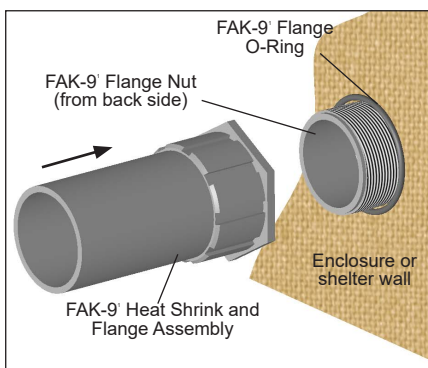

6. Insert Flange Nut into bulkhead hole and engage Flange Assembly as shown. Tighten firmly by hand. If further tightening is desired, use suitable spanner wrench ensuring not to over-tighten as Flange Nut can be broken.

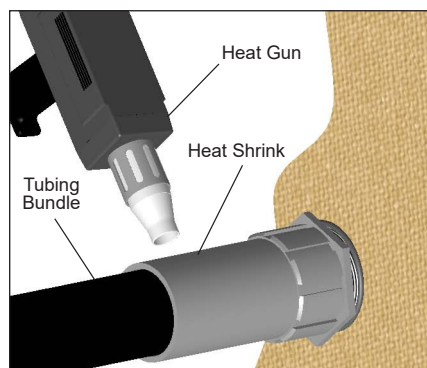

7. It is recommended that the tubing, heat trace (where included) and other connections be made before completing this step. Heat until heat shrink seal is conformed and sealed to the tube bundle outer jacket.

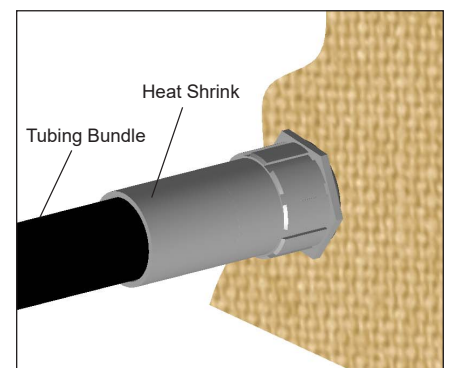

8. Completed FAK-9 installation.

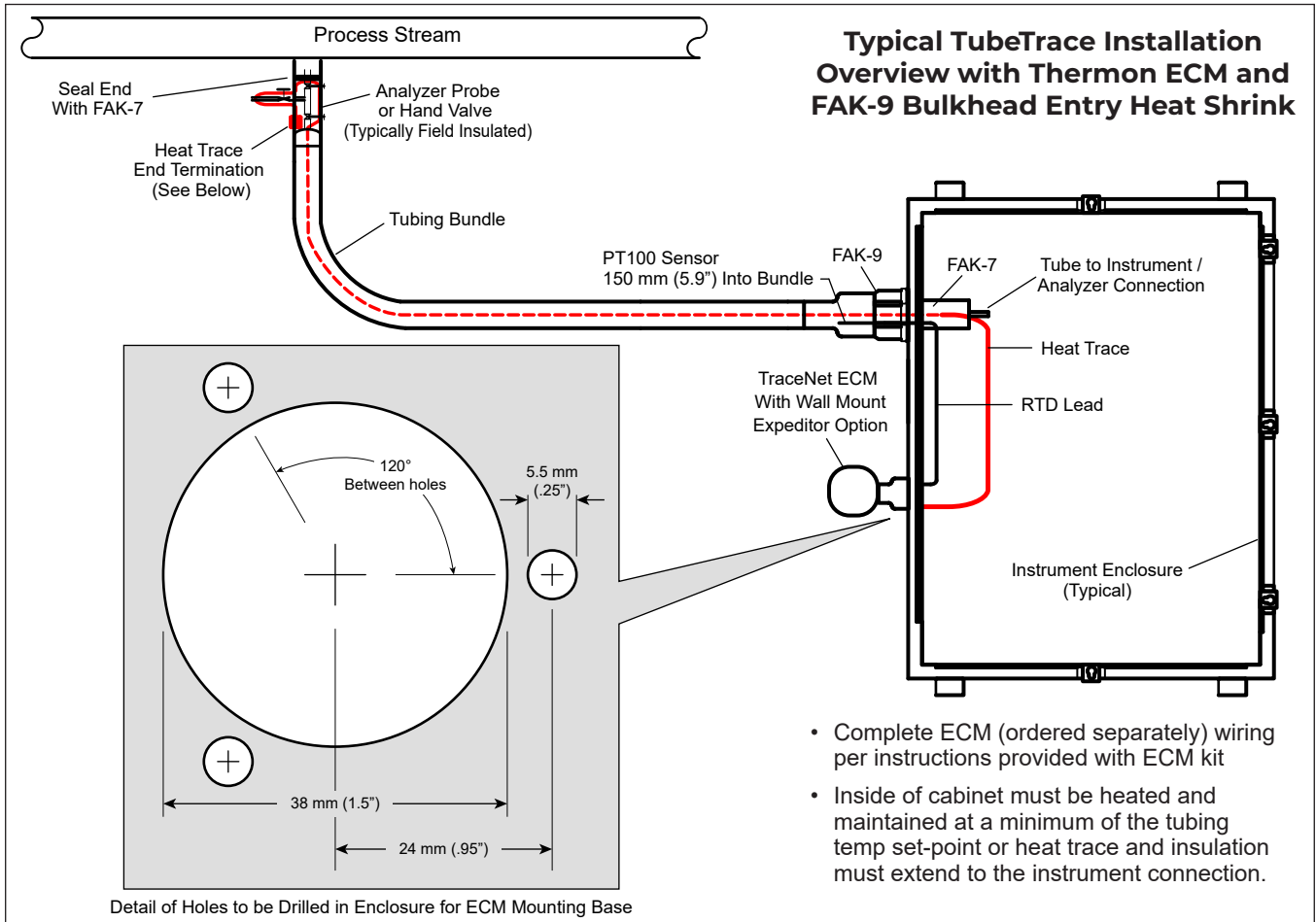

**End Termination**

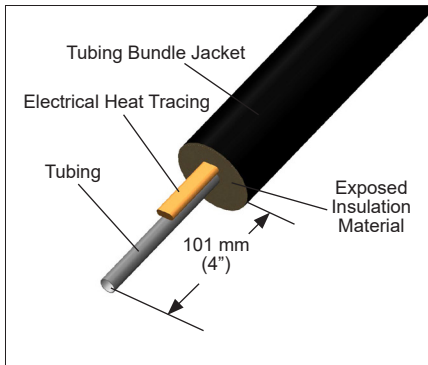

**9.** Strip back insulation approximately 101 mm (4") from tubing bundle end.

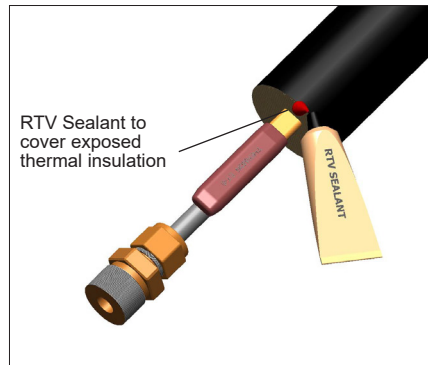

**10.** Deburr end of tubing and make necessary field installation connections. Make-up end termination and/or power connection per instructions included with the appropriate termination kit (order separate from the FAK-7). Liberally apply RTV sealant to tubing bundle insulation.

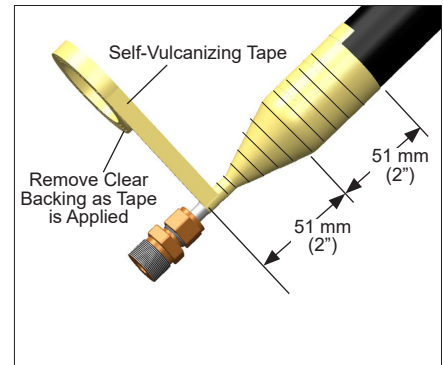

**11.** While removing the clear backing from tape, wrap end of tubing bundle with self-vulcanizing tape. Start a minimum of 51 mm (2") above the cut on the outer jacket and continue a minimum of 51 mm (2") along the bare tubing. Overlap the tape at least 50%. It is recommended that the heater end terminations be sealed and placed inside the insulation or at the connection, to assure no moisture enters the bundle insulation.

