

SCTK

Splice Connection Termination Kit

INSTALLATION PROCEDURES

- SCTK-1 for BSX, VSX-HT**
- SCTK-2 for KSX, HTSX, USX**
- SCTK-3 for HPT, FP**

To be used in conjunction with
Thermon connection kits

Made in the USA 

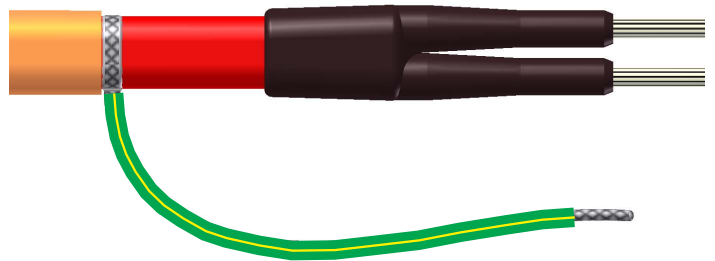

SCTK

The following installation procedures are guidelines for the installation of the Splice Connection Termination Kit. For translations other than English and local language translation provided here, please contact Thermon. The English language installation procedure shall govern.

Receiving, Storing and Handling

1. Inspect materials for damage incurred during shipping.
2. Report damages to the carrier for settlement.
3. Identify parts against the packing list to ensure the proper type and quantity has been received.
4. Store in a dry location.

Splice Connection Termination Kits (per cable)

SCTK-1	for BSX, VSX-HT
SCTK-2	for HTSX, KSX, USX
SCTK-3	for HPT, FP

Kit Contents

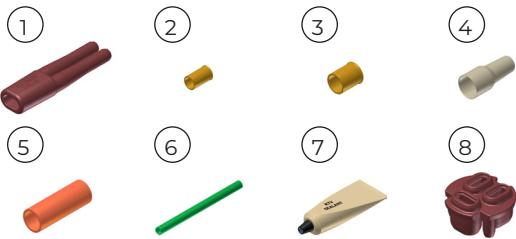

Item	Quantity	Description
1	2	Splice Connection Boots
2	2	Small Crimps
3	1	Large Crimp
4	2	Small Crimp Insulators
5	2	Silicone Caps
6	3	Ground Sleeves (not used with ZE-B Kits)
7	1	RTV Tube
8	1	GRW-G (FP and HPT only)

Warnings

- Due to the risk of electrical shock, arcing and fire caused by product damage or improper usage, installation or maintenance, a ground-fault protection device is required.
- Installation must comply with Thermon requirements (including form PN 50207U for Ex systems) and be installed in accordance with the regulations as per the norm EN IEC 60079-14 for hazardous areas (where applicable), or any other applicable national and local codes.
- Component approvals and performance ratings are based on the use of Thermon specified parts only.
- De-energize all power sources before opening enclosure.
- Keep ends of heating cable and kit components dry before and during installation.
- Minimum bending radius of heating cable is 32 mm (except HPT is 57 mm and FP is 19 mm).
- Individuals installing these products are responsible for complying with all applicable safety and health guidelines. Proper Personal Protective Equipment (PPE) should be utilized during installation. Contact Thermon if you have any additional questions.
- Avoid electrostatic charge. Clean only with a damp cloth.

SCTK Certifications/Approvals¹



Note:

1. Certifications vary by cable type. See heating cable installation procedures for additional information.

Tools Required

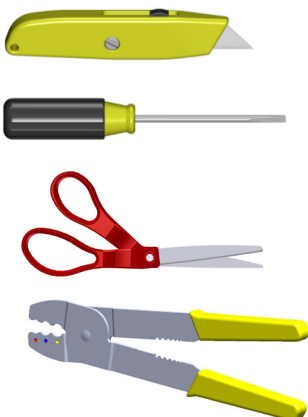

IMPORTANT!

Heating cable must be properly installed within expediter assembly and mounted to pipe prior to terminating with SCTK kit.

See Terminator Installation Instructions for expediter mounting details.

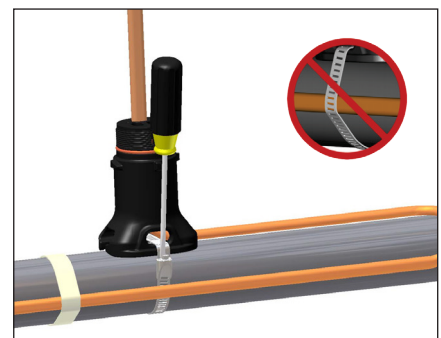

Terminator: Route cable through base entry and mount expediter to pipe using pipe band. **Do not band over cable.**

Note: For HPT and FP cable exchange grommet in Terminator with GRW-G provided in SCTK-3.

INSTALLATION PROCEDURES

Step 1: Remove Heating Cable Overjacket and Separate Metallic Braid to Form Pigtail

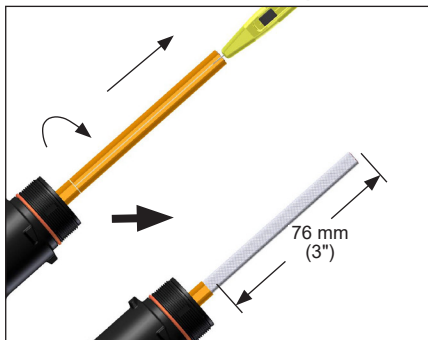

1a. Cut and remove heating cable overjacket.

 **Do not cut metallic braid.**

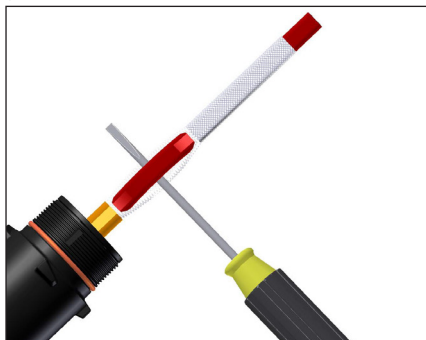

1b. Separate braid strands at edge of overjacket and pull cable through opening in braid.

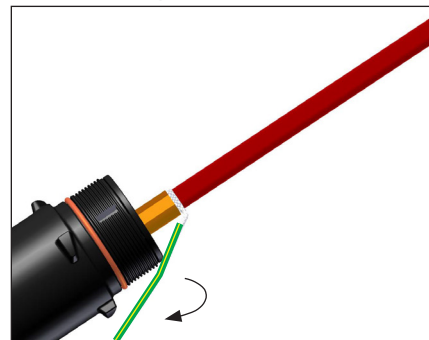

1c. Twist braid into a pigtail. Trim ends of braid and apply ground sleeve.

Step 2: Matrix Removal for BSX, VSX-HT, HTSX, RSX, KSX, USX Cables

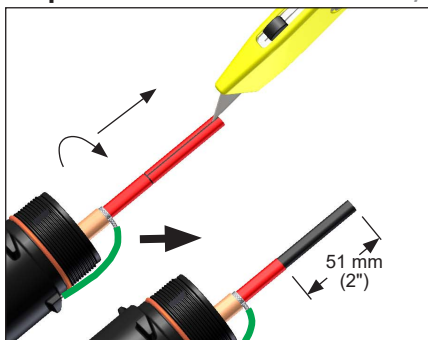

2a. Cut and remove primary insulation jacket (BSX, RSX, and RRT cables only).

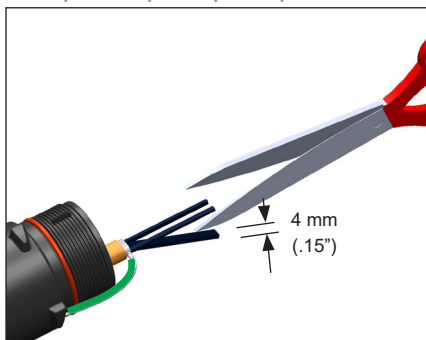

2b. Cut a 4 mm strip of conductive matrix between the conductors.

 **Do not cut bus wire strands.**

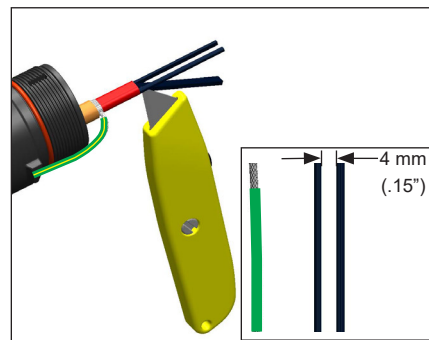

2c. Cut and remove the 4 mm matrix strip.

Step 2: Heating Element Removal for HPT and FP Cables

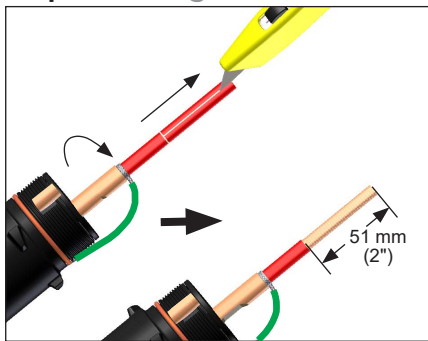

2a. Cut and remove primary insulation jacket.

NOTE: Bus connection must be no more than 50 mm (2") from pipe as addressed in connection kit instructions.

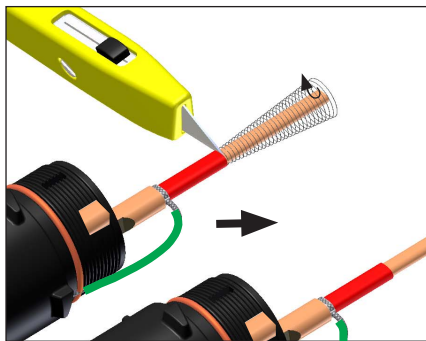

2b. Cut and remove fiberglass overlay and heating element. Push any remaining heating element wire under the primary insulation jacket.

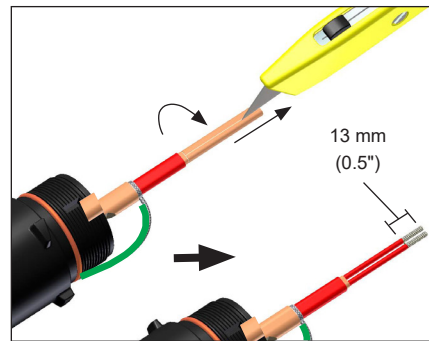

2c. Cut and remove pairing jacket. Remove insulation from ends of bus wires.

 **Do not cut bus wire insulation.**

Step 3: Install Power Boot on Heating Cables

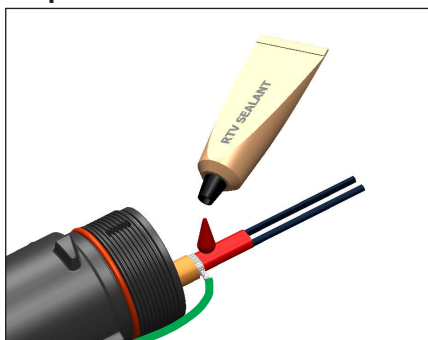

3a. Apply RTV sealant to cable to cover distance of at least 3 mm and slide boot onto the end of the cable.

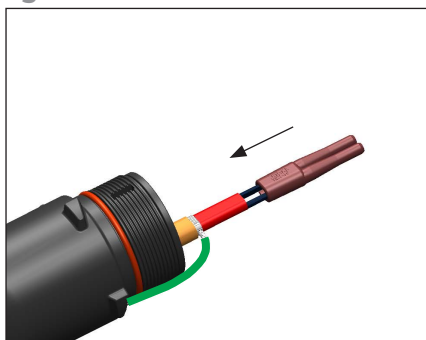

3b. Slide boot onto the end of the cable.

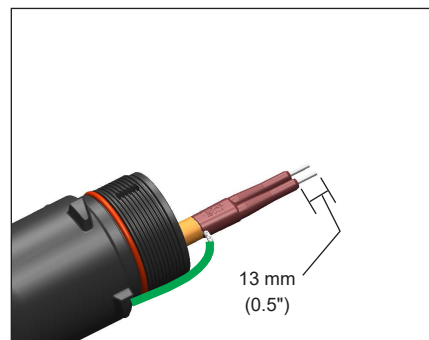

3c. Expose 13 mm (0.5") of bus wire.

Cable Take-off for BSX, RSX, HTSX, KSX, USX, and VSX-HT

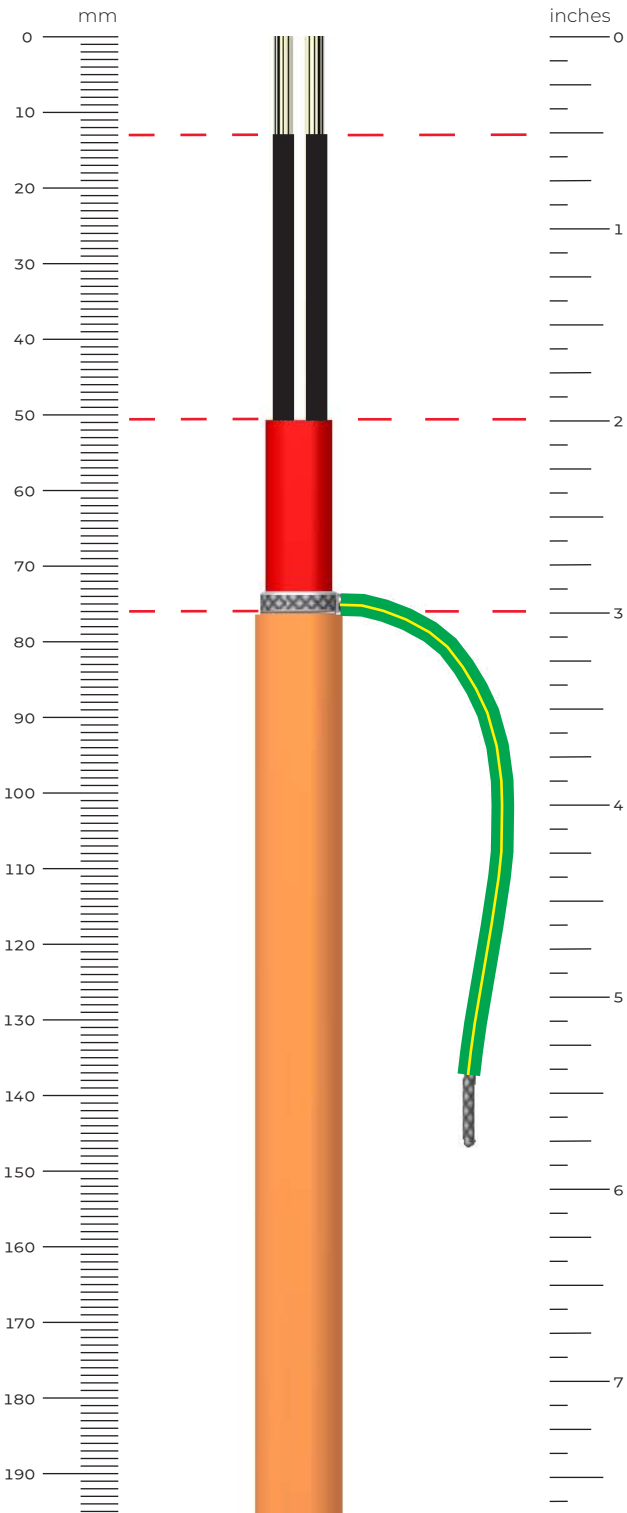

For Power Connection Boot Termination

Cable Take-off for HPT and FP

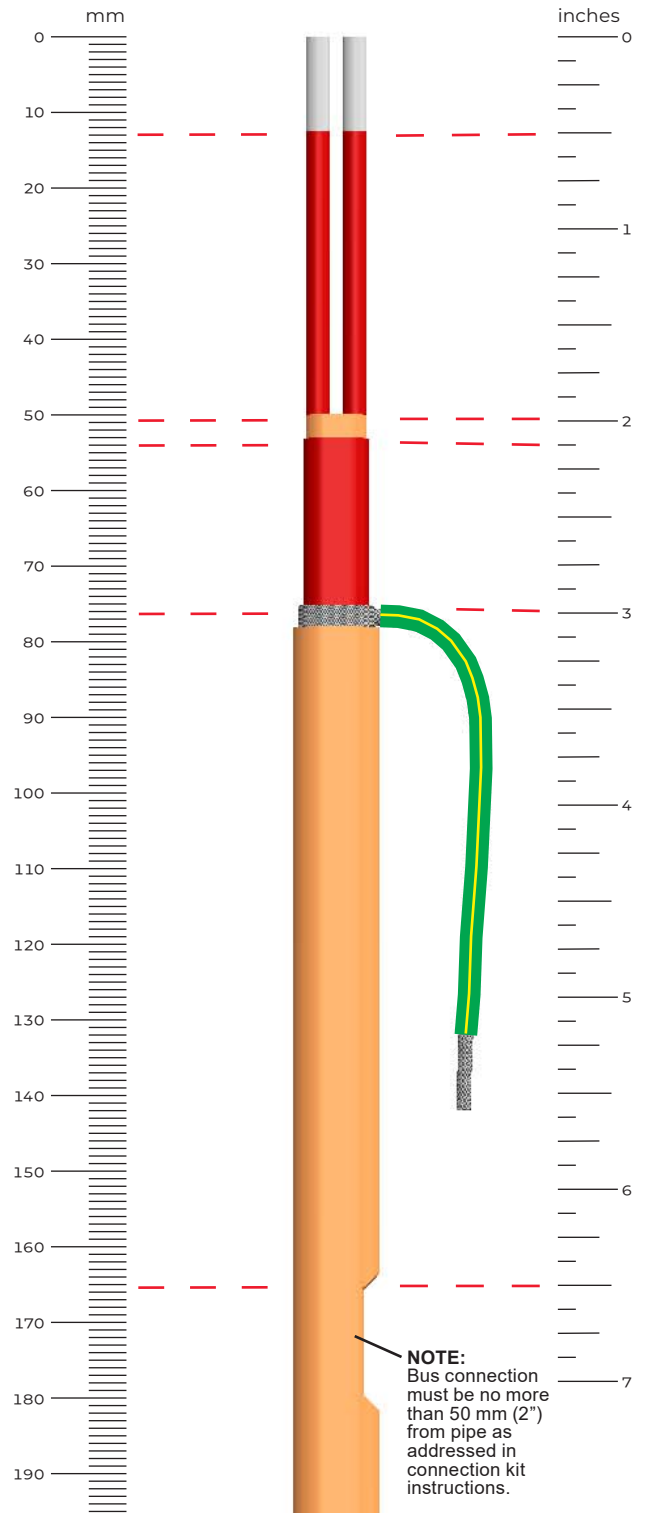

NOTE:
Bus connection must be no more than 50 mm (2") from pipe as addressed in connection kit instructions.

For Power Connection Boot Termination

NOTE: Images may not be printed to scale.

