

Terminator™ ZS/ZE

In Line Splice/End Termination Kit

INSTALLATION PROCEDURES

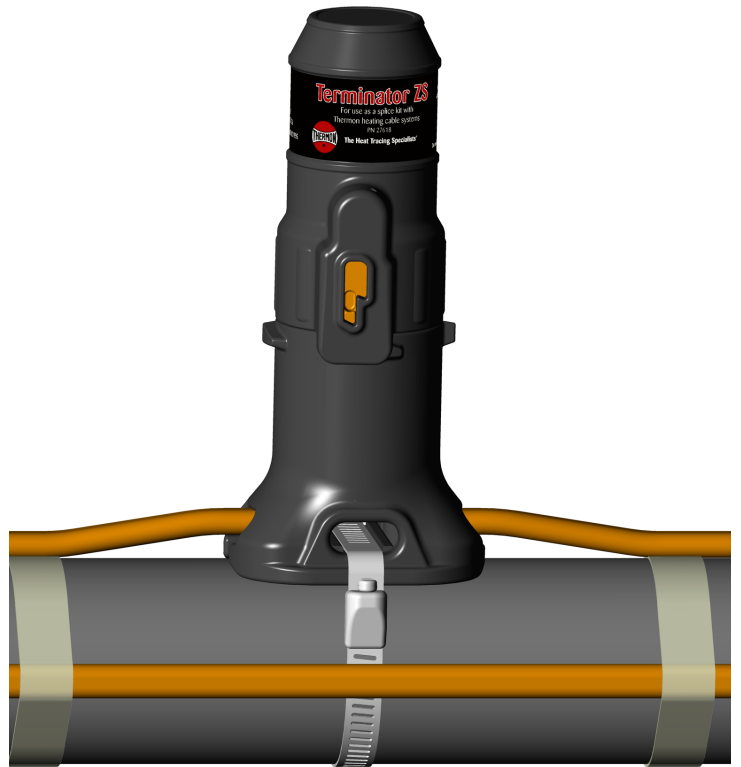

For In-Line Splice Connection and End Termination Applications



Terminator™ ZS/ZE

The following installation procedures are guidelines for the installation of the In Line Splice/End Termination Kit. For translations other than English and local language translation provided here, please contact Thermon. The English language installation procedure shall govern.

Kit Contents



Item	Quantity	Description
1	1	Expediter Assembly Grommet Compressor Grommet Support Base with O-Ring
2	1	Splice Cap
3	1	Banding Guide
4	1	Banding

Order Separately for End Termination

PETK Power and End Termination Kits (per cable)

- PETK-1 for BSX, RSX, VSX-HT
- PETK-2 for USX, KSX, HTSX,
- PETK-3 for FP, HPT

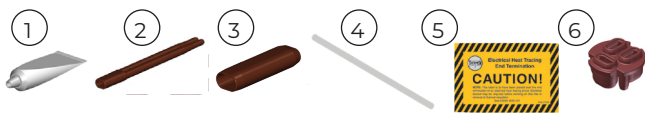

Item	Quantity	Description
1	1	RTV Tube
2	1	Power Connection Boot
3	1	End Cap
4	1	Tape Strip Teflon 6" (PETK-3 only)
5	1	End Termination Caution Label
6	1	GRW-G Grommet (PETK-3 only)

Order Separately for Inline Splice

SCTK Splice Connection Termination Kits (per cable)

- SCTK-1 for BSX, RSX, VSX-HT
- SCTK-2 for USX, KSX, HTSX,
- SCTK-3 for FP, HPT

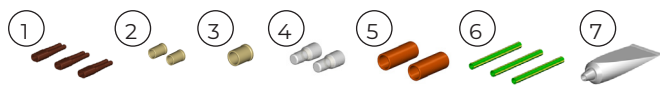

Item	Quantity	Description
1	3	Splice Connection Boots
2	2	Small Crimps
3	1	Large Crimp
4	2	Small Crimp Insulators
5	2	Silicone Caps
6	3	Ground Sleeves
7	1	RTV Tube

Dimensions

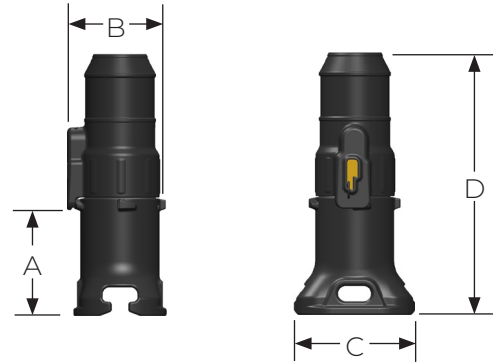

	A	B	C	D
	inch (mm)	inch (mm)	inch (mm)	inch (mm)
Terminator ZS/ZE	3" (75 mm)	3" (75 mm)	3-1/2" (90 mm)	7-3/4" (200 mm)

Tcode Instructions

Temperature code is based on the rating of the electrical heat tracing cables for which the connection kits are intended to be used.

Warnings

- Due to the risk of electrical shock, arcing and fire caused by product damage or improper usage, installation or maintenance, a ground-fault protection device is required.
- Installation must comply with Thermon requirements and be installed in accordance with the regulations as per the norm EN IEC 60079-14 for hazardous areas (where applicable), or any other applicable national and local codes.
- Component approvals and performance ratings are based on the use of Thermon specified parts only.
- De-energize all power sources before opening enclosure.
- Avoid electrostatic charge. Clean only with a damp cloth.
- Keep ends of heating cable and kit components dry before and during installation.
- Minimum bending radius of heating cable is 32 mm (except HPT is 57 mm and FP is 19 mm).
- Individuals installing these products are responsible for complying with all applicable safety and health guidelines. Proper Personal Protective Equipment (PPE) should be utilized during installation. Contact Thermon if you have any additional questions.

Tools Required

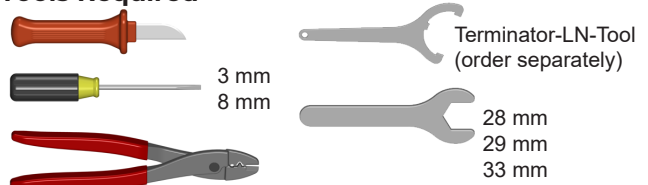

Certifications/Approvals

IP66 -60°C ≤ Ta ≤ +55°C
Ordinary & Hazardous Locations

IEC Ex FMG 10.0022X Ex eb IIC T6...T4 Gb
Ex tb IIIC T85°C...T135°C Db

CE 0344 Ex II 2 GD Ex eb IIC T6...T4 Gb, Ex tb IIIC T85°C...T135°C Db
FM 10ATEX0058X

Terminator has additional hazardous area approvals including:

- GGTN • Kazakhstan

INSTALLATION PROCEDURES

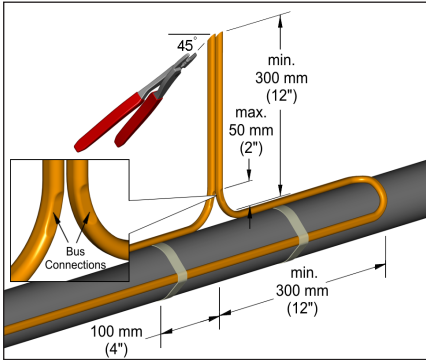

1. Locate bus connection (HPT and FP only) and cable as shown. Cut end of cable at angle to aid in piercing grommet. Leave additional cable for expansion loop. See page 4 for multiple cable installation tips.

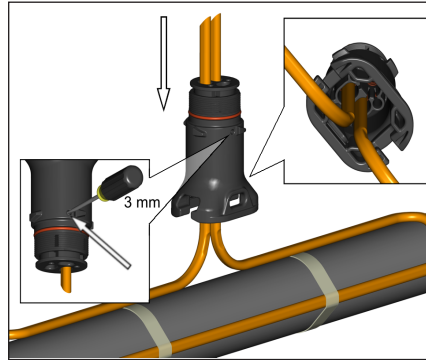

2. Insert cable into expediter. If mounted on bottom or side of pipe, punch out weep hole.

Note: For HPT and FP cable, exchange grommet in Terminator with GRW-G provided in PETK-3.

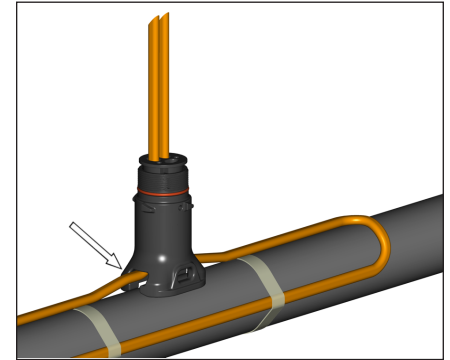

3. Slide expediter toward pipe and route cable through support base entry.

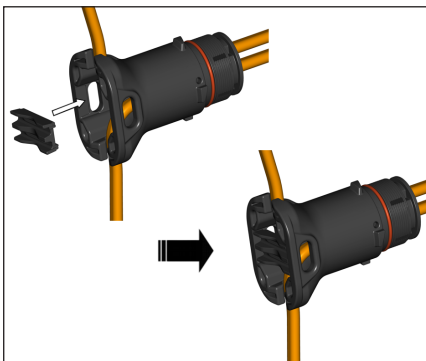

4. Insert banding guide into expediter and snap into place.

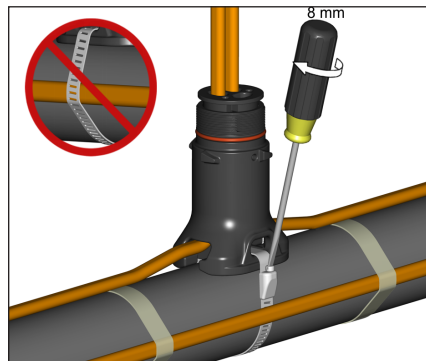

5. Mount expediter to pipe using pipe band. Do not band over cable.

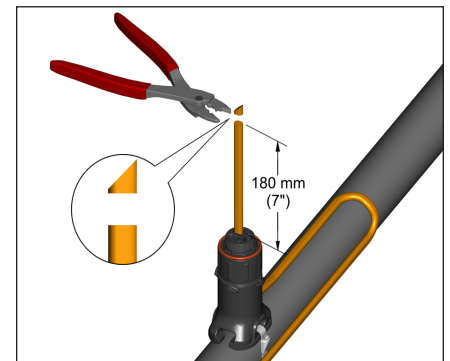

6. Cut off end of cable.

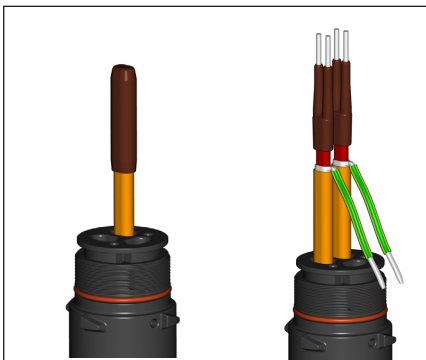

7. Terminate cable with appropriate PETK termination kit. Refer to PETK installation instructions.

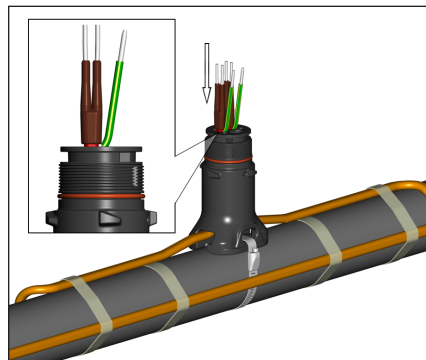

8. Push excess cable back through expediter. Tighten cap securely. Tape cable expansion loop to pipe.

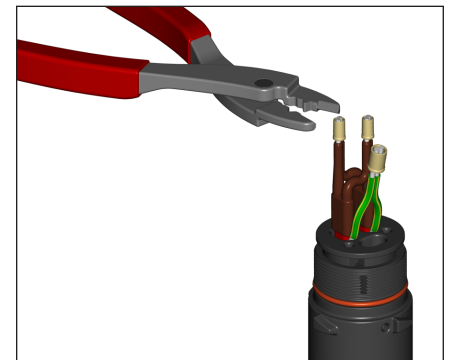

9. Connect bus wires using small crimps and connect ground wires using large crimp. See page 9 for wiring details. Trim excess wire if necessary.

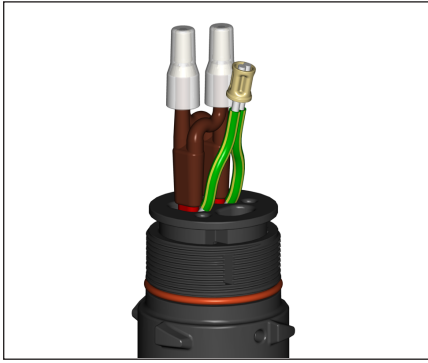

10. Snap on crimp insulators

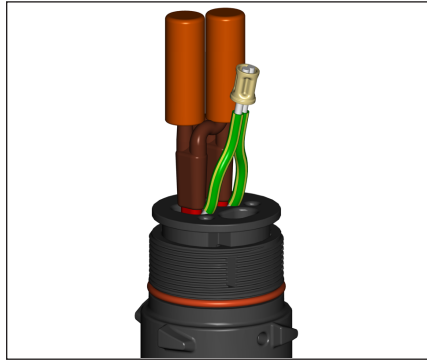

11. Slide silicone caps over crimp insulators.

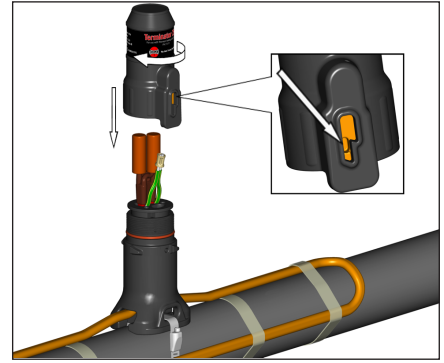

12. Tighten cap securely.

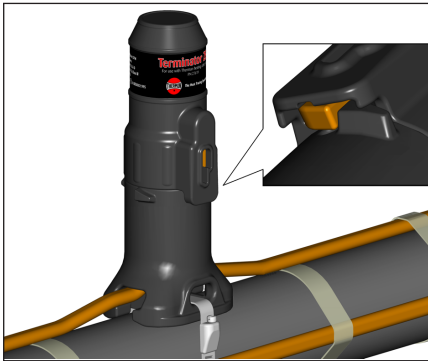

13. Completed splice kit. Make sure latch mechanism is in the locked position.



14. To remove cap, lift latch mechanism and unscrew cap.

Wiring Details

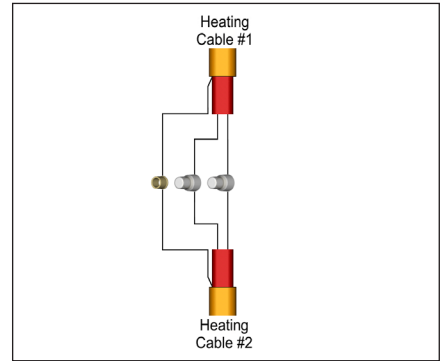

In-Line Splice

