

Terminator™ ZP-M

Power Connection Kit for Power Connection, In-Line Splice Connection, or End Termination Applications

INSTALLATION PROCEDURES



Terminator™ ZP-M

The following installation procedures are suggested guidelines for the installation of the Terminator ZP-M Kit. For translations other than English and local language translation provided here, please contact Thermon. The English language installation procedure shall govern.

Receiving, Storing and Handling

1. Inspect materials for damage incurred during shipping.
2. Report damages to the carrier for settlement.
3. Identify parts against the packing list to ensure the proper type and quantity has been received.
4. Store in dry area.

Kit Contents



Item	Quantity	Description
1	1	Expediter Assembly Support Cap with O-Ring Threaded Grommet Compressor Grommet Support Base with O-Ring
2	1	Junction Box Lid
3	1	Junction Box Base with O-Ring and M25 Dust Cap
4	1	Nut
5	1	Banding
6	1	Banding Guide
7	1	Terminal Blocks with DIN Rail (Refer to terminal specifications for maximum allowable wire size)
8	1	Junction Box Cord
9	1	Terminal Block Jumper
10	1	Ground Sleeve
11	1	Blind Plug

Dimensions

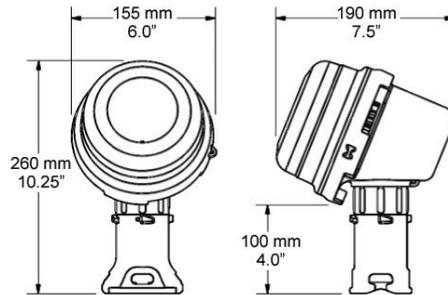

Warnings

- Due to the risk of electrical shock, arcing and fire caused by product damage or improper usage, installation or maintenance, a ground-fault protection device is required.
- Installation must comply with Thermon requirements (including form PN 50207U for Ex systems) and be installed in accordance with the regulations as per the norm EN IEC 60079-14 for hazardous areas (where applicable), or any other applicable national and local codes.
- Component approvals and performance ratings are based on the use of Thermon specified parts only.
- De-energize all power sources before opening enclosure.
- Avoid electrostatic charge. Clean only with a damp cloth.
- Keep ends of heating cable and kit components dry before and during installation.
- Individuals installing these products are responsible for complying with all applicable safety and health guidelines. Proper Personal Protective Equipment (PPE) should be utilized during installation. Contact Thermon if you have any additional questions.

Tools Required

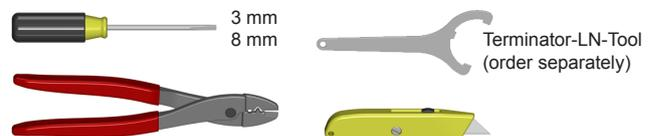

Certifications/Approvals

IP66 -60°C ≤ Ta ≤ +55°C

Ordinary & Hazardous Locations



FMG 10.0022X Ex eb IIC T6...T4 Gb
Ex tb IIIC T85°C...T135°C Db



II 2 GD Ex eb IIC T6...T4 Gb, Ex tb IIIC T85°C...T135°C Db
FM 10ATEX0058X

Thermon has additional hazardous area approvals including:

- GGTN • Kazakhstan

INSTALLATION PROCEDURES

Cable Type	Cable Type	Cable Type
HTEK 3C60	HTEK 3C40	HTEK 2C50
HTEK 3C50	HTEK 3C30	HTEK 2C40
TEK 3C70	HTEK 2C70	HTEK 2C30
	HTEK 2C60	TEK 3C40
	TEK 3C60	TEK 3C30
	TEK 3C50	TEK 2C60
	TEK 2C70	TEK 2C50
		TEK 2C40
		TEK 2C30

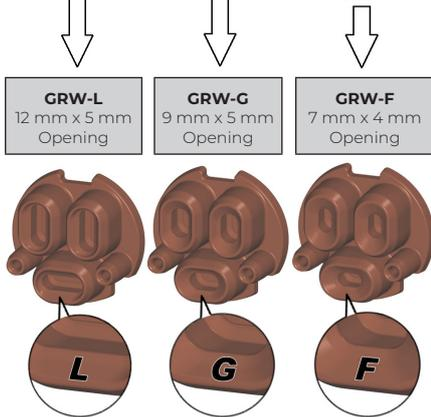

1. Select appropriate grommet for specific cable type.

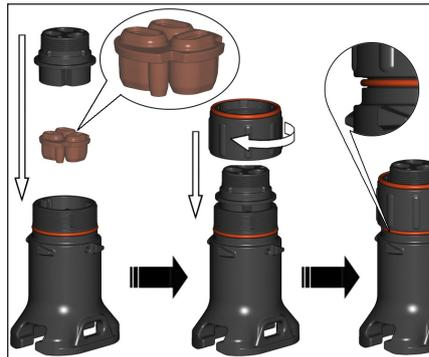

2. Put together expeditor assembly. Place grommet in support base. Snap threaded grommet compressor into support base. Screw support cap onto support base.

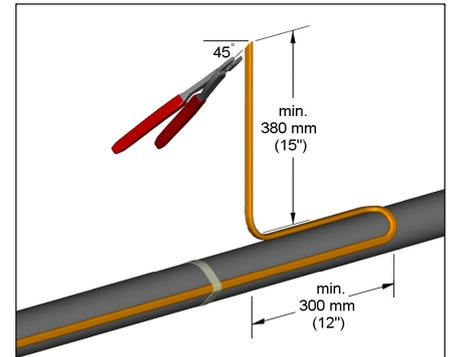

3. Cut end of cable at angle to aid in piercing grommet. Leave additional cable for expansion loop. See page 5 for in-line splice (two cable) installation tips.

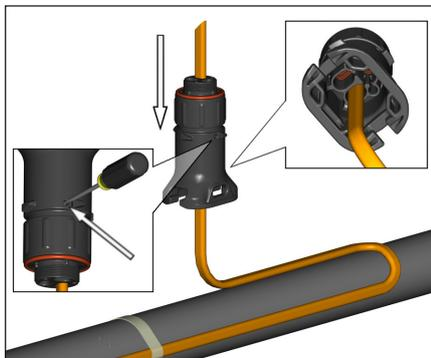

4. Insert cable into expeditor. If mounted on bottom or side of pipe, punch out weep hole.

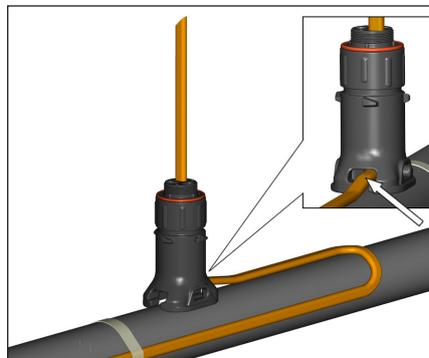

5. Slide expeditor toward pipe and route cable through support base entry.

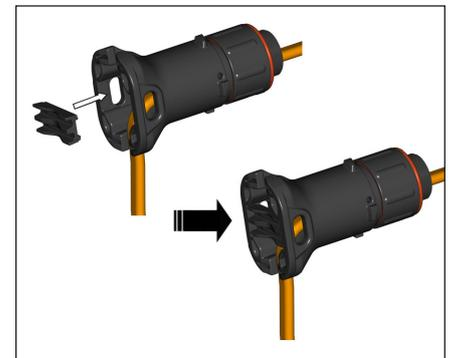

6. Insert banding guide into expeditor and snap into place.

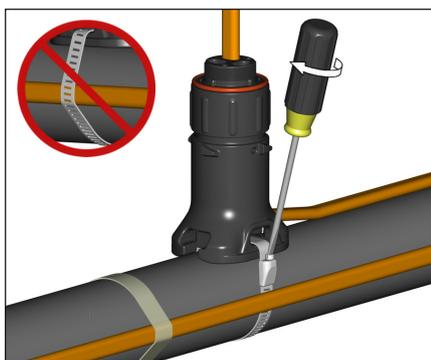

7. Mount expeditor to pipe using pipe band. Do not band over cable.

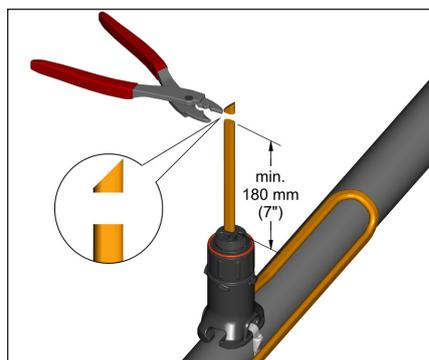

8. Cut off end of cable.

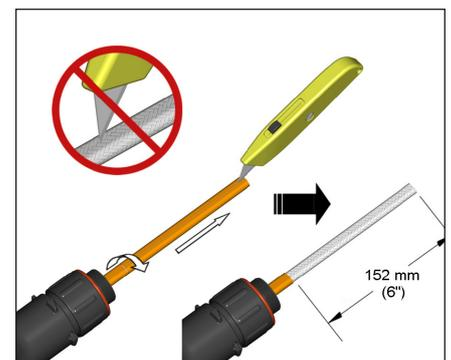

9. Cut and remove overjacket by scoring overjacket and bending cable. Do not cut metallic braid.

Terminator™ ZP-M

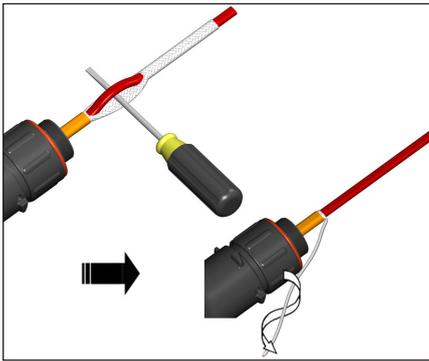

10. Separate braid strands at edge of overjacket and pull cable through opening in braid. Twist braid into a pigtail. Trim ends of braid.

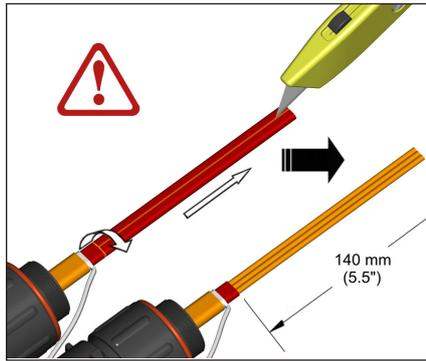

11. Cut and remove pairing jacket by scoring pairing jacket and bending cable. Do not cut insulation on conductors.

Note: Three (3) conductor cable is shown in the instructions and is representative of two (2) conductor cable installations.

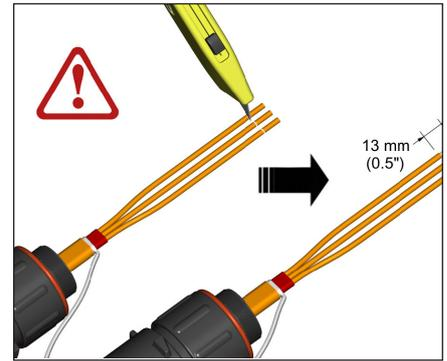

12. Remove insulation and fiberglass braid (HTEK only) from ends of each conductor. Do not cut bus wire strands.

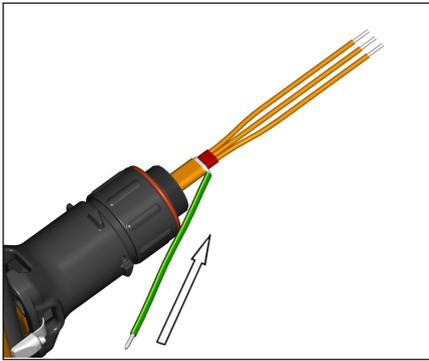

13. Slide green/yellow ground sleeve over twisted braid.

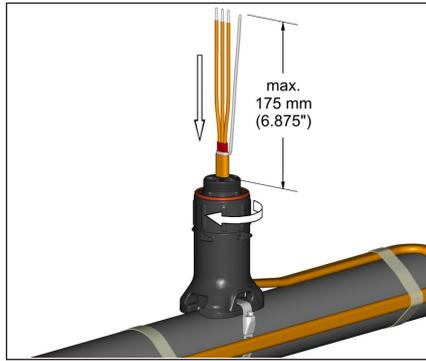

14. Push excess cable back through expediter. Tighten cap securely. Tape cable expansion loop to pipe.

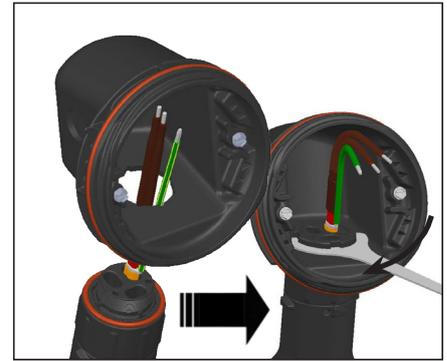

15. Mount junction box base on expediter. Make sure to align slots to properly orient junction box base. Tighten nut with Terminator-LN-Tool. If mounting horizontally, threaded gland holes must face downward.

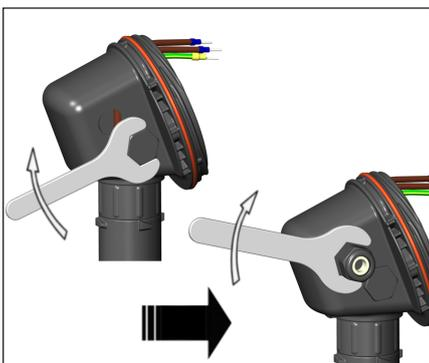

16. Remove M25 dust cap. Install M25 power gland (order separately) and M25 blind plug. For in-line splice or end termination, install additional M25 blind plug (order M25-B-EXE separately) instead of M25 power gland.

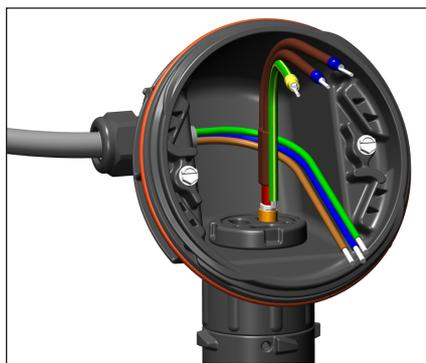

17. For power connection applications: Install power connection fittings (user supplied) and pull in power and ground wires.



18. Install terminal block and complete system wiring. Tightening torque 1.5 Nm–1.8 Nm (1.1 ft-lb–1.3 ft-lb).

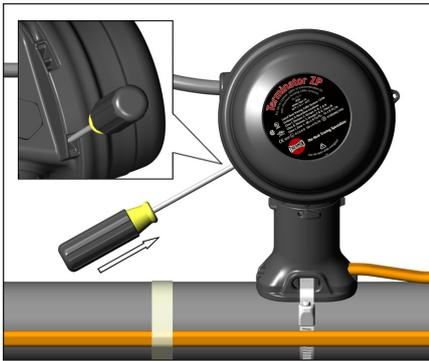

20. Install junction box lid and twist hand tight. Insert screwdriver into ratchet slots located on side of junction box base.

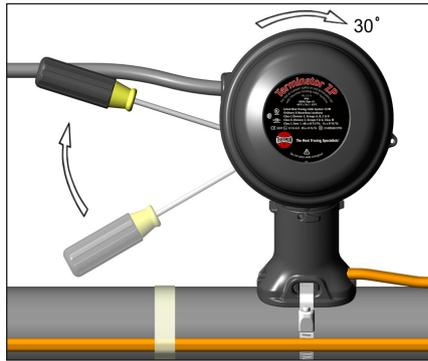

21. Use screwdriver to ratchet on junction box lid. Lid will rotate 30 degrees.

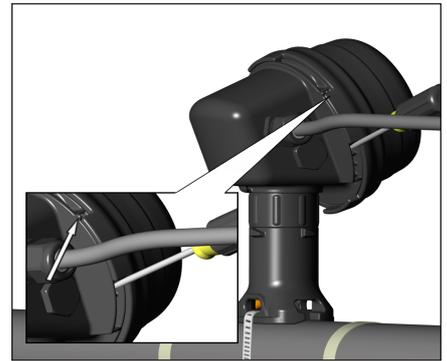

22. Lid latch mechanism fully engaged. To remove lid, repeat steps 20 and 21 but in the opposite direction.

In-line Splice Layout Tips

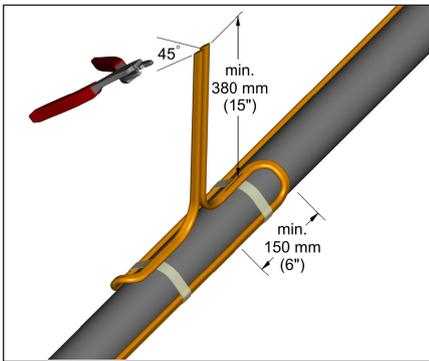

A1. Cut end of cable at angle to aid in piercing grommet. Leave additional cable for expansion loop.

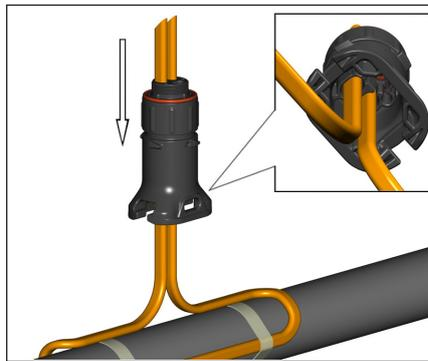

A2. Insert two cables into expediter.

Wiring Details Two Conductors

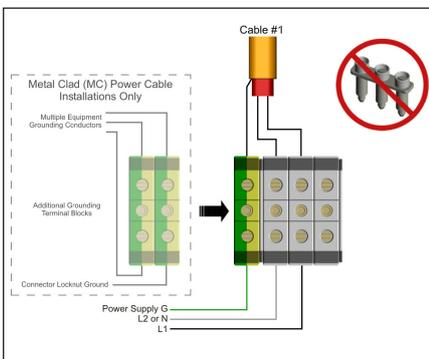

B1. Power Connection (1 Cable)

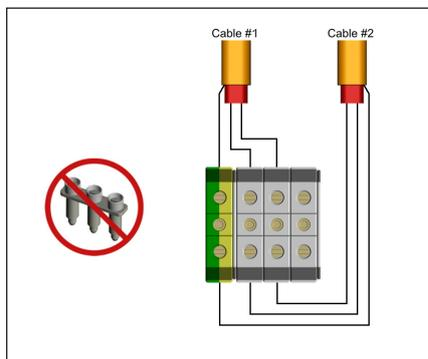

B2. In-line splice.

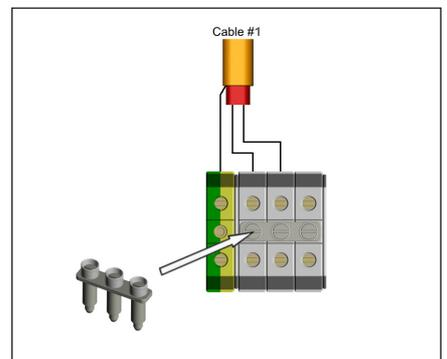

B3. End Termination (1 Cable Only). Install jumper to terminal blocks.

Wiring Details Three Conductors

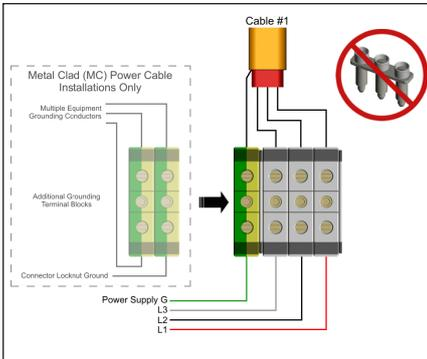

C1. Power Connection (1 Cable)

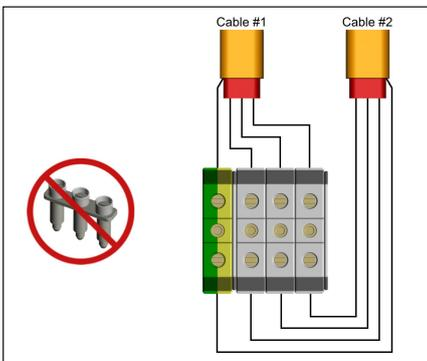

C2. In-line splice.

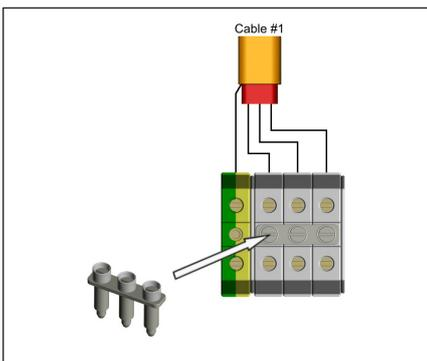

C3. End Termination (1 Cable). Install jumper to terminal blocks.

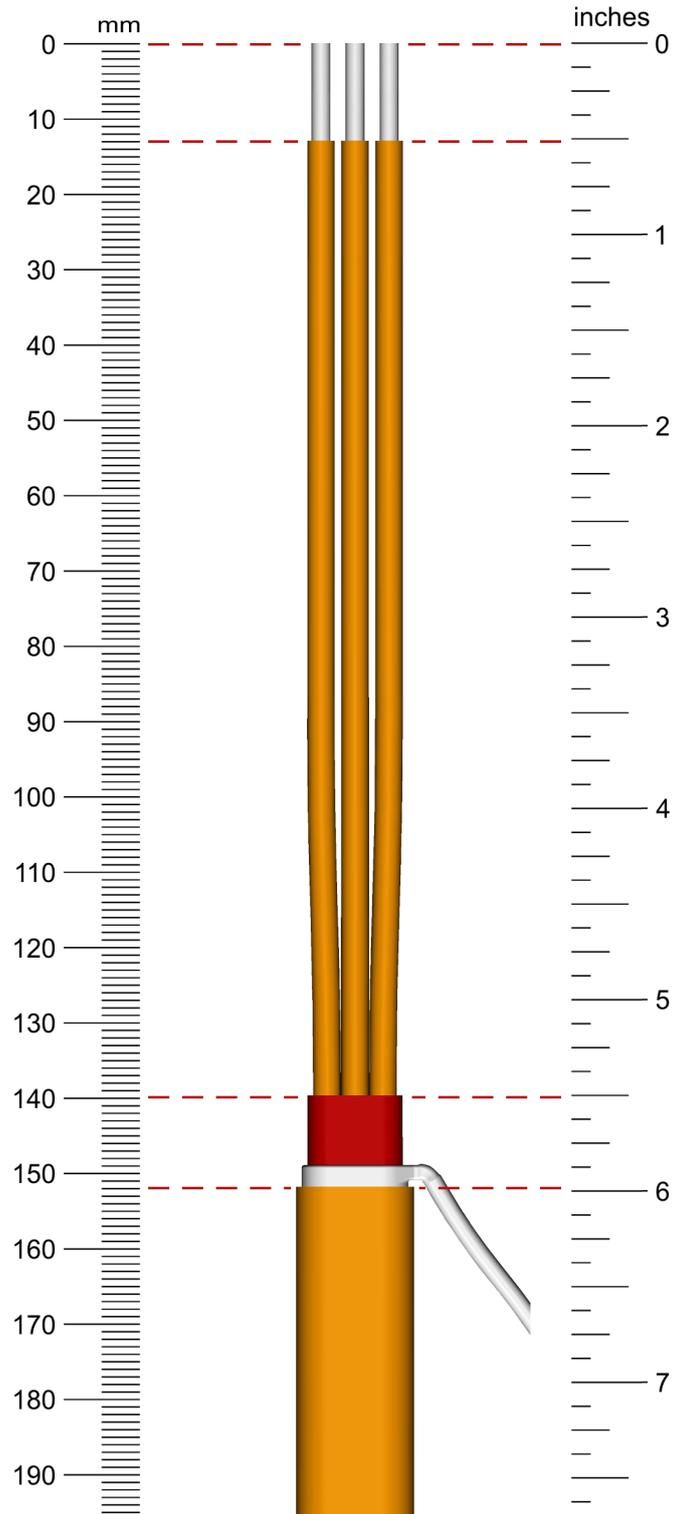

NOTE:
Images may not be printed to scale.

