

Terminator™ ZE-B Beacon LED End of Circuit Light Kit

INSTALLATION PROCEDURES



Terminator™ ZE-B Beacon

The following installation procedures are suggested guidelines for the installation of the Terminator ZE-B Beacon. For translations other than English and local language translation provided here, please contact Thermon. The English language installation procedure shall govern.

Kit Contents



Item	Quantity	Description
1	1	Expediter Assembly Grommet Compressor Grommet Support Base with O-Ring
2	1	Light Module Cover
3	1	Banding Guide
4	1	Banding
5	1	LED Light Module

Order Separately

SCTK Connection Termination Kits (per cable)

- SCTK-1 for BSX, RSX, VSX-HT
- SCTK-2 for KSX, HTSX, USX
- SCTK-3 for FP, HPT

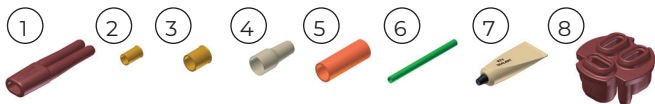

Item	Quantity	Description
1	2	Splice Connection Boots
2	2	Small Crimps
3	1	Large Crimp
4	2	Small Crimp Insulators
5	2	Silicone Caps
6	3	Ground Sleeves (not used with ZE-B Kits)
7	1	RTV Tube
8	1	GRW-G (FP and HPT only)

Order Separately

SCTK Terminal Block Connection Kits (per cable)

- SCTK-1TB for BSX, RSX, VSX-HT
- SCTK-2TB for KSX, HTSX, USX
- SCTK-3TB for FP, HPT



Item	Quantity	Description
1	1	Terminal Block
2	1	Terminal Block Mounting Screw
3	1	Splice Connection Boot
4	1	RTV Tube
5	1	GRW-G Grommet (SCTK-3TB only)

Receiving, Storing and Handling

1. Inspect materials for damage incurred during shipping.
2. Report damages to the carrier for settlement.
3. Identify parts against the packing list to ensure the proper type and quantity has been received.
4. Store in a dry location.

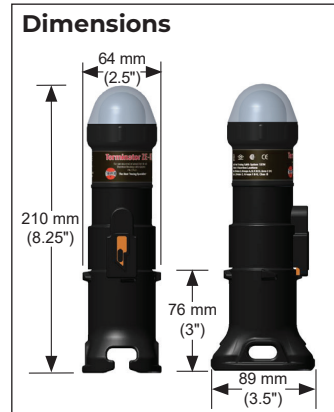

Installation Precautions

- To minimize the potential for arcing and fire caused by product damage or improper installation use ground-fault protection.
- Installation must comply with Thermon requirements and be installed in accordance with the applicable national and local codes.
- Component approvals and performance ratings are based on the use of Thermon specified parts only.
- De-energize all power sources before opening enclosure.
- Keep ends of heating cable and kit components dry before and during installation.
- Individuals installing these products are responsible for complying with all applicable safety and health guidelines. Proper personal protective equipment, or PPE, should be utilized during installation. Contact Thermon if you have any additional questions.

The Specific Conditions of Use are:

1. The kits are intended for use with ATEX certified BSX, HTSX, KSX, RSX, USX, VSX-HT, HPT, and FP heat tracing.
2. The equipment can only be used in areas of low impact risk.
3. Avoid electrostatic charge. Clean only with a damp cloth.
4. The maximum operating voltage rating is limited to 275 VAC when wiring is done using the terminal block option.
5. The minimum ambient temperature rating is limited to -50°C when the equipment is wired using the terminal block option.

Tools Required

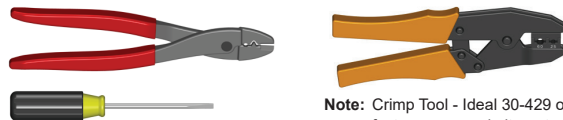

Note: Crimp Tool - Ideal 30-429 or factory approved alternate.

Certifications/Approvals

IP66 -60°C ≤ Ta ≤ +45°C
Ordinary & Hazardous Locations
IEC Ex FMG 10.0022X Ex eb mb IIC T6 Gb
Ex tb IIIC T85°C Db

UK CA 0306 CE 0344 Ex II 2 GD Ex eb mb IIC T6...T5 Gb, Ex tb IIIC T85°C Db, FM 18ATEX0065X, FM22UKE0072X

Terminator has additional hazardous area approvals including:

- GGTN · Kazakhstan

INSTALLATION PROCEDURES

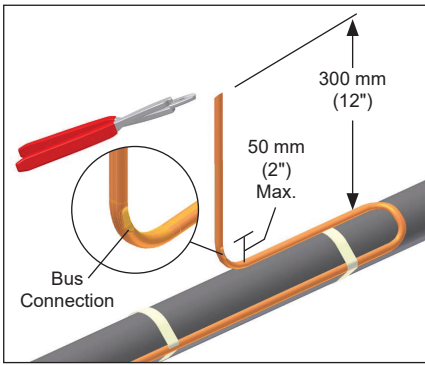

1. Locate bus connection (HPT and FP only) and cable as shown. Cut end of cable at angle to aid in piercing grommet. Leave additional cable for expansion loop.

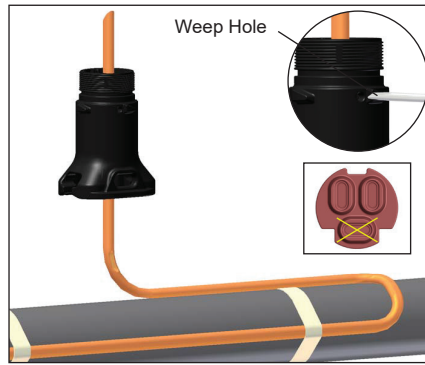

2. Insert cable into expediter. If mounted on bottom of pipe, punch out weep hole.
Note: For HPT and FP cable, exchange grommet in terminator with GR-G provided in PETK-3.

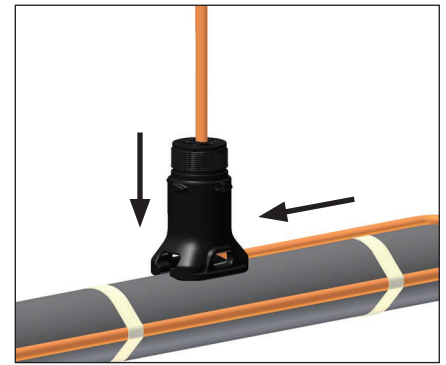

3. Slide expediter toward pipe and route cable through support base entry.

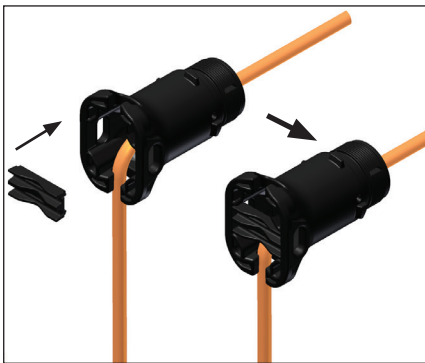

4. Insert banding guide into expediter and snap into place.



5. Mount expediter to pipe using pipe band. Do not band over cable.

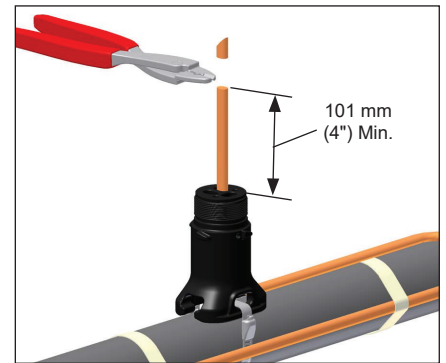

6. Cut off end of cable.

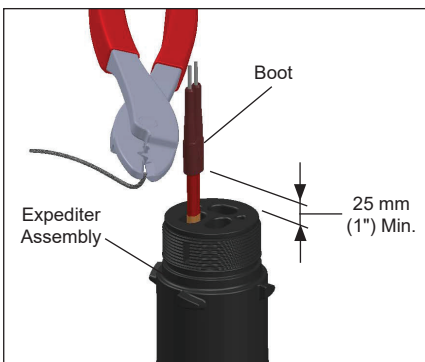

7. Terminate cable with appropriate SCTL termination kit. Refer to SCTL installation instructions. Push excess cable back through expediter. Remove braid pigtail. Tape cable expansion loop to pipe.

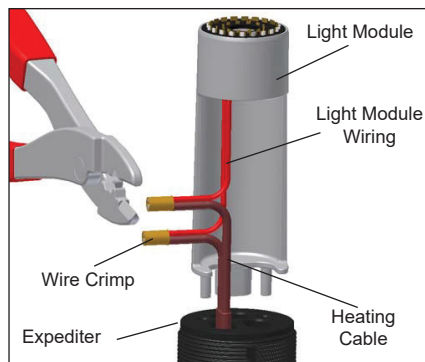

8. **When using crimps:** Connect heating cable to light module wires using small crimps. See steps 8-11.
When using terminal block: See steps 12-14. See wiring schematic for connection details.

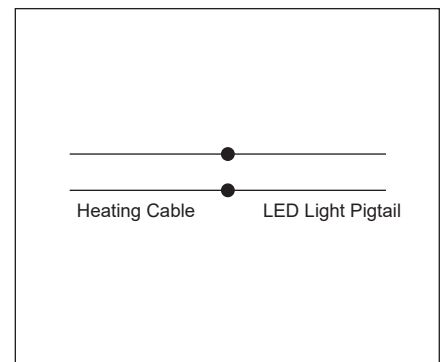

Wiring Details for LED Light

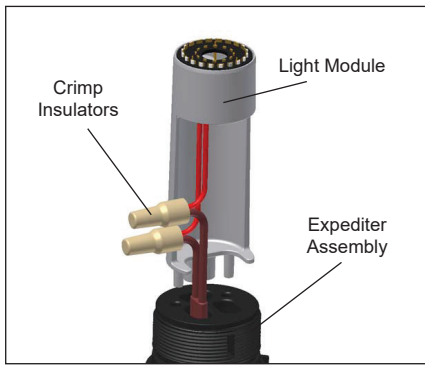

9. Snap on crimp insulators.

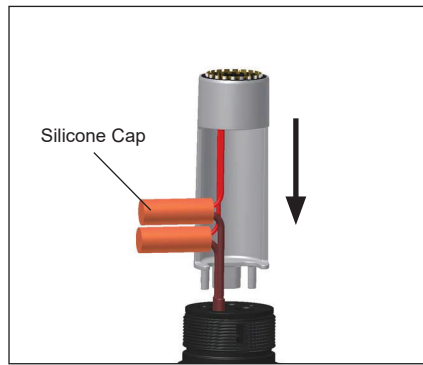

10. Slide silicone caps over crimp insulators. Install Light Module to Expediter.

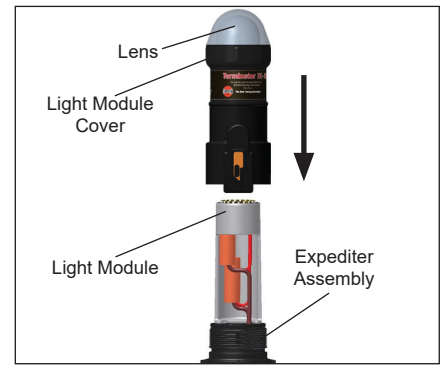

11. Arrange crimped leads to fit inside light module base. Slide the light module cover over light module.

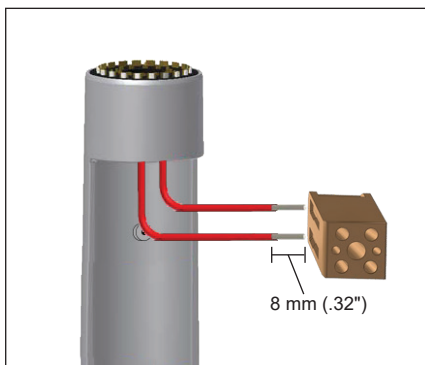

12. When using SCK-TB Connection Kit, first trim exposed bus wires of the LED pigtail to 8 mm (.32"), then connect to the terminal block.

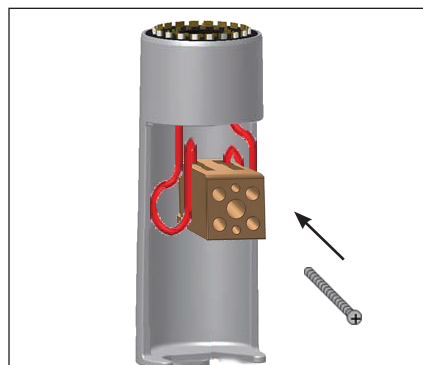

13. Use the terminal block mounting screw to mount terminal block to the LED light module. Bend each pigtail lead around the sides of the terminal block.

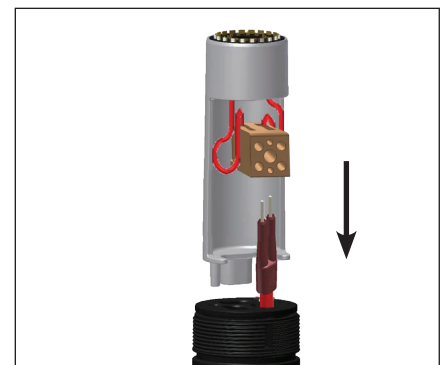

14. Connect the bus wires of the trace heater to the terminal block.



15. Engage threads. Rotate light module cover clockwise and tighten cap securely. Make sure latch mechanism is in the locked position.

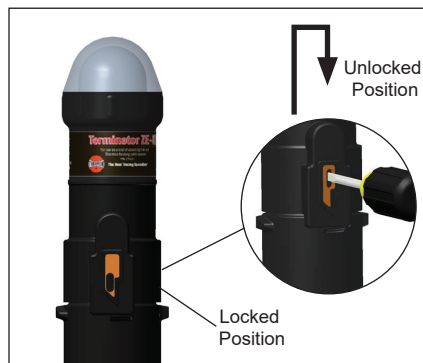

16. To remove cap, de-energize circuit, lift latch mechanism, and unscrew cap.

