

FAK-1

For Bulkhead Entry of
Tubing Bundles

INSTALLATION PROCEDURES



FAK-1: Split Bulkhead Entry Kit

The following installation procedures are suggested guidelines for the installation of the FAK-1:

Receiving, Storing and Handling

1. Inspect materials for damage incurred during shipping.
2. Report damages to the carrier for settlement.
3. Identify parts against the packing list to ensure the proper type and quantity has been received.
4. Store in dry location.

FAK-1: Split Bulkhead Entry Kit



FAK-1: Bulkhead Kit Contents

Item	Quantity	Description
1	1	Bulkhead Entry Cover (Top)
2	1	Bulkhead Entry Cover (Bottom)
3	1	Silicone Gasket
4	1	Heat Reflective Tape
5	1	Glass Fiber Tape
6	1	RTV Sealant Tube
7	1	Self-Vulcanizing Tape

Provided by others — 8 each 8-32 stainless steel bolts, washers and nuts required.

Dimensions

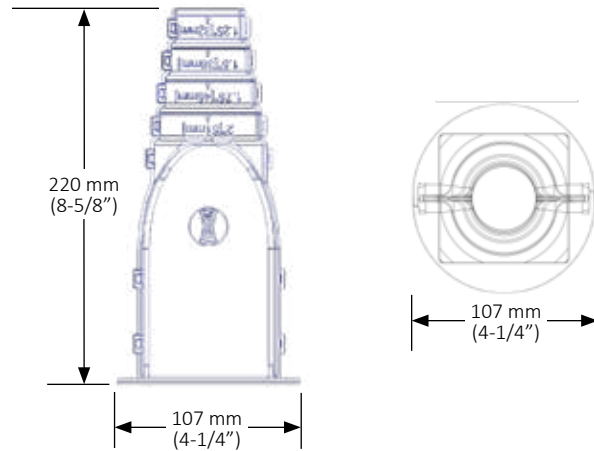

If Electrically Heat Traced

- To minimize the potential for arcing on electric heat tracing and fire caused by product damage or improper installation use ground-fault protection, the National Electrical Code (NEC) and Canadian Electrical Code (CEC) require ground-fault protection of equipment for each branch circuit supplying electric heat tracing.
- Installation must comply with Thermon requirements and be installed in accordance with applicable national and local codes.
- Component approvals and performance ratings are based on the use of Thermon specified parts only. User supplied power connection fittings must be listed or certified for intended use.
- De-energize all power sources before opening enclosure.
- Keep ends of bundles, heat tracing and kit components dry before and during installation.
- Individuals installing these products are responsible for complying with all applicable safety and health guidelines. Proper personal protective equipment, or PPE, should be utilized during installation. Contact Thermon if you have any additional questions.

Tools Required



INSTALLATION PROCEDURES

If Electrically Heat Traced

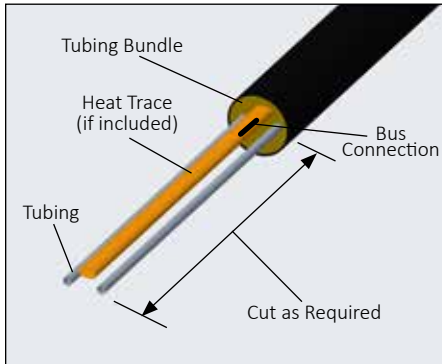

- Strip back bundle insulation as required, leaving desired length of tubing for connection.

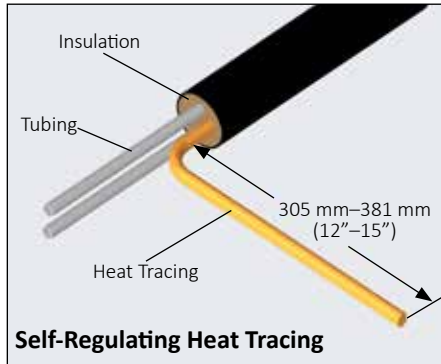

Self-Regulating Heat Tracing

- Trim heat tracing to within 305 mm–381 mm (12”–15”) of the end of the insulation. If self regulating heat trace proceed to step 3. For Zone-type heat trace continue with indentation of bus connection on step 2a.

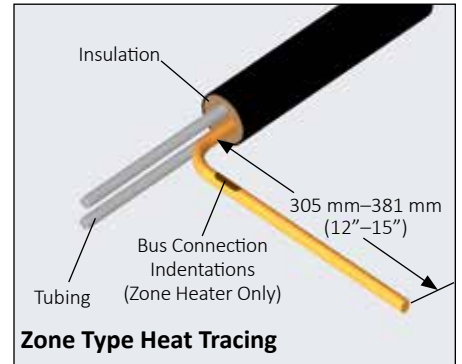

Zone Type Heat Tracing

- Strip back bundle insulation 38 mm to 76 mm (1-1/2”–3”) beyond bus connection heat tracing. If bus connection indentation is less than 305 mm–381 mm (12”–15”) from end of the heat tracing, proceed stripping the bundle insulation to the next indentation.

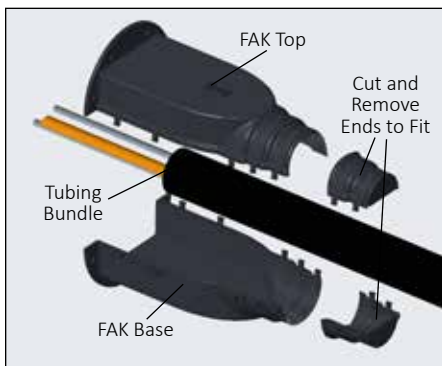

- Using the dimensions on the bulkhead entry covers, locate the correct size, ensuring a snug fit. Identify the correct cut line and cut top and bottom FAK covers.

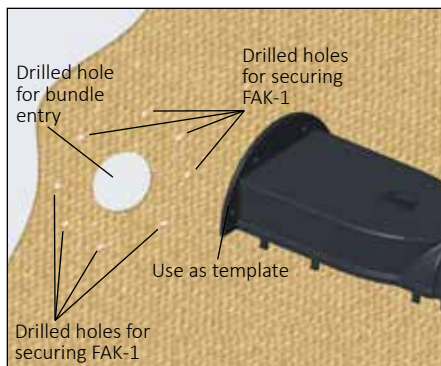

- Field drill required entry hole in wall/plate. Use the FAK-1 flange as a template and mark and drill holes for bolts.

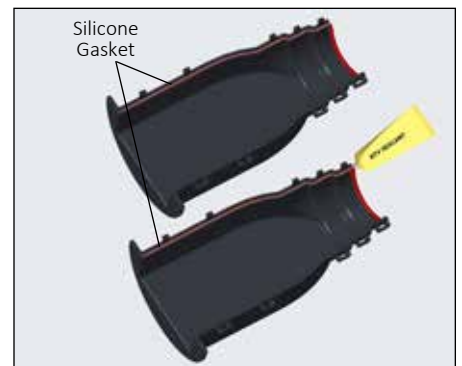

- Install RTV silicone and gasket, cutting off excess. Apply RTV sealant to both halves.

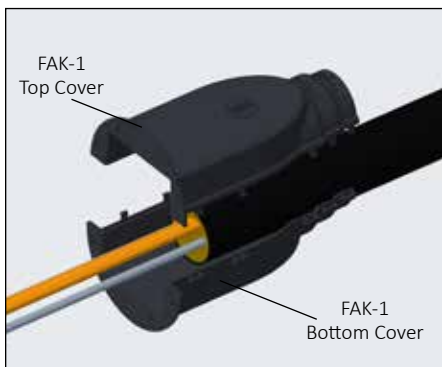

- Snap both halves together firmly. Inspect ends of tubing bulkhead entry cover for snug fit. Apply additional RTV sealant where needed.



- Apply self-vulcanizing tape around bundle jacket and work up over FAK ends.

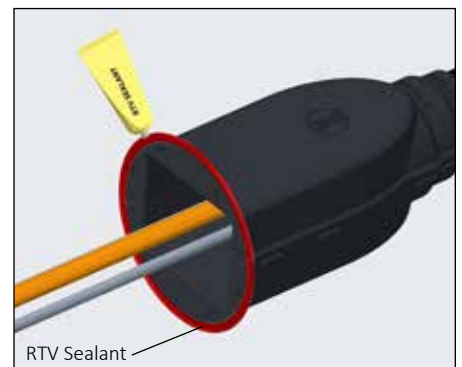

- Apply RTV bead to back of FAK-1 flange prior to securing to bulkhead.

FAK-1: Split Bulkhead Entry Kit

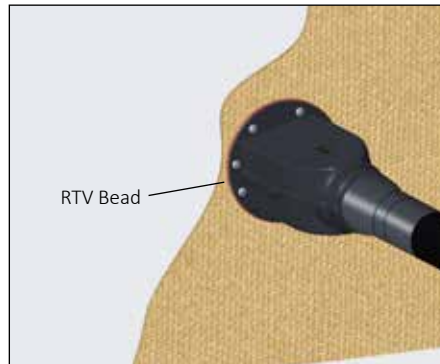
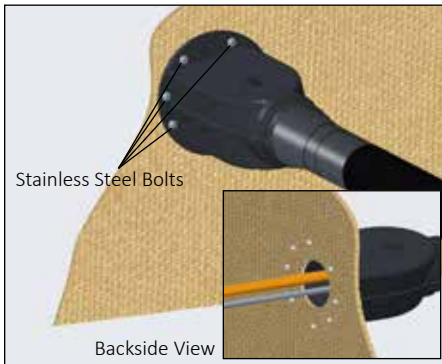

9. Secure FAK-1 to bulkhead/wall using (8) eight stainless steel bolts (provided by others). Complete tubing and heat trace connections or termination.
10. Apply RTV bead around FAK-1 flange. Completed FAK-1 kit.

