

SCTK

Splice Connection Termination Kit

INSTALLATION PROCEDURES

- SCTK-1D** for **BSX, RSX, VSX**
- SCTK-2D** for **KSX, HTSX**
- SCTK-3D** for **HPT, FP**

To be used in conjunction with
Thermon Connection kits



The Heat Tracing Specialists[®]

Receiving, Storing and Handling . . .

1. Inspect materials for damage incurred during shipping.
2. Report damages to the carrier for settlement.
3. Identify parts against the packing list to ensure the proper type and quantity has been received.
4. Store in a dry location.

Splice Connection Termination Kits (per cable)

SCTK-1D for BSX, RSX, VSX

SCTK-2D for KSX, HTSX

SCTK-3D for HPT, FP

Kit Contents . . .



Item	Quantity	Description
1	2	Splice Connection Boots
2	1	Large Wire Nut
3	2	Medium Wire Nuts
4	2	Small Wire Nuts
5	1	RTV Tube
6	1	GRW-G Grommet (For SCTK-3D Terminator kits only)

Installation Precautions . . .

- To minimize the potential for arcing and fire caused by product damage or improper installation use ground-fault protection. The National Electrical Code (NEC) and Canadian Electrical Code (CEC) require ground-fault protection of equipment for each branch circuit supplying electric heat tracing.
- Installation must comply with Thermon requirements and be installed in accordance with the NEC, CEC, or any other applicable national and local codes.
- Component approvals and performance ratings are based on the use of Thermon specified parts only.
- De-energize all power sources before opening enclosure.
- Keep ends of heating cable and kit components dry before and during installation.
- Individuals installing these products are responsible for complying with all applicable safety and health guidelines. Proper Personal Protective Equipment (PPE) should be utilized during installation. Contact Thermon if you have any additional questions.

SCTK Certifications/Approvals¹ . . .



Note:

1. These sets have been evaluated as components of Thermon's Approved connection kits, such that the area use ratings depend on the rating of the connection kits.

Tools Required . . .

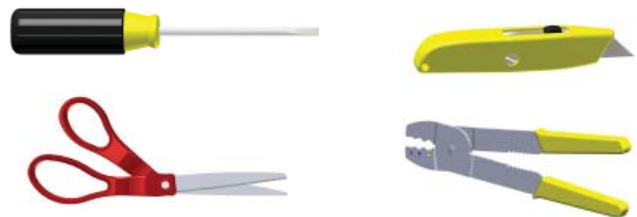

IMPORTANT!

Heating cable must be properly installed within expediter assembly and mounted to pipe prior to terminating with SCTK kit.

See Terminator or TracePlus Installation Instructions for expediter mounting details.



Terminator: Route cable through base entry and mount expediter to pipe using pipe band. **Do not band over cable.**

Note: For HPT and FP cable exchange grommet in Terminator with GRW-G provided in SCTK-3D.

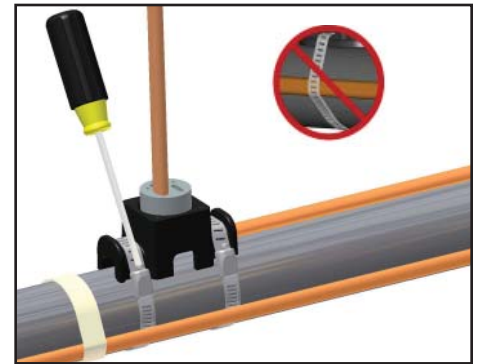

TracePlus: Route cable through base entry and mount expediter to pipe using pipe band. **Do not band over cable.**

Step 1: Remove Heating Cable Overjacket and Separate Metallic Braid to Form Pigtail

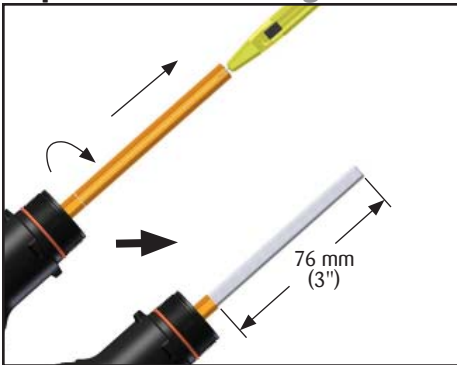

1a. Cut and remove heating cable overjacket.

Do not cut metallic braid.

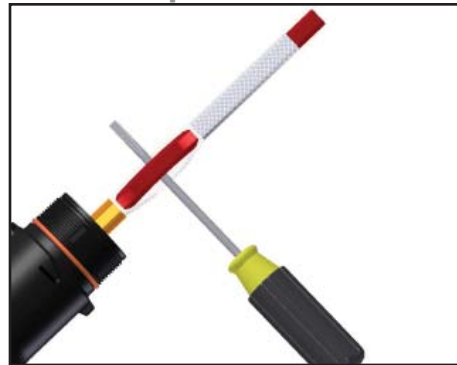

1b. Separate braid strands at edge of overjacket and pull cable through opening in braid.



1c. Twist braid into a pigtail. Trim ends of braid.

Step 2: Matrix Removal for BSX, RSX, HTSX, KSX, and VSX Cables

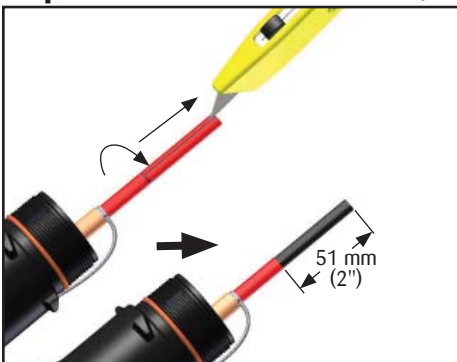

2a. Cut and remove primary insulation jacket (BSX and RSX cables only).

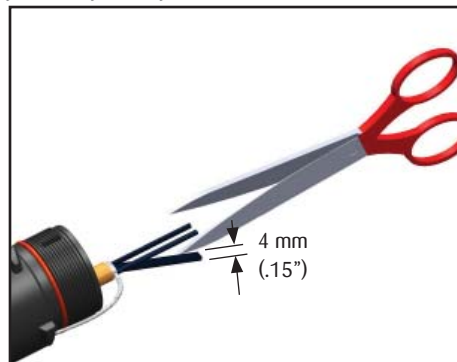

2b. Cut a 4mm strip of conductive matrix between the conductors.

Do not cut bus wire strands.

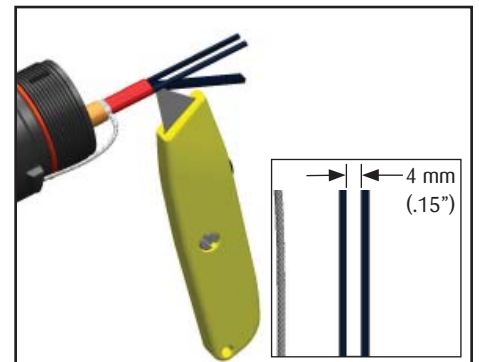

2c. Cut and remove the 4mm matrix strip.



Step 2: Heating Element Removal for HPT and FP Cables

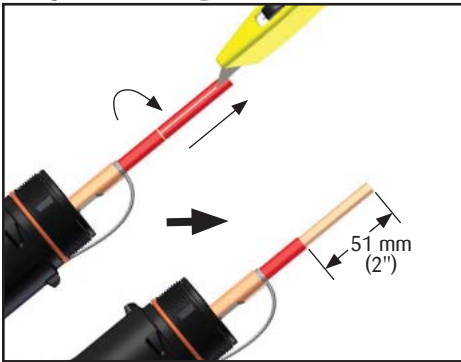

2a. Cut and remove primary insulation jacket.

NOTE: Bus connection must be no more than 50 mm (2") from pipe as addressed in connection kit instructions.

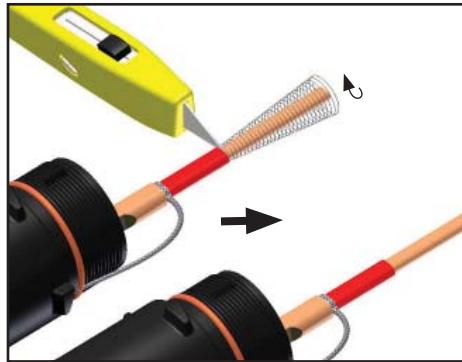

2b. Cut and remove fiberglass overlay and heating element. Push any remaining heating element wire under the primary insulation jacket.

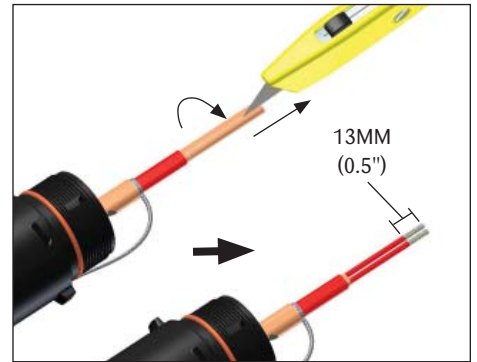

2c. Cut and remove pairing jacket. Remove insulation from ends of bus wires.



Do not cut bus wire insulation.

Step 3: Install Power Boot on Heating Cables



3a. Apply a liberal amount of RTV sealant to cable.

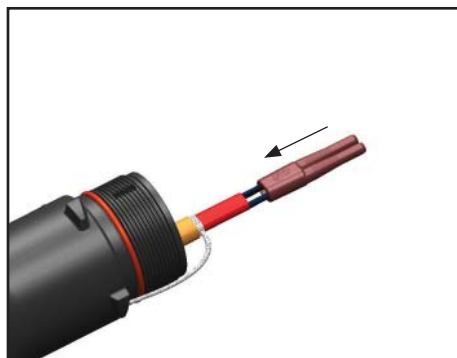

3b. Slide boot onto the end of the cable.

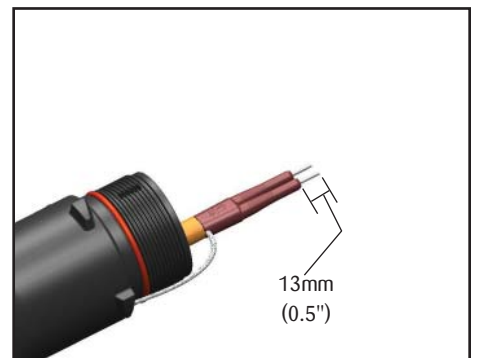

3c. Expose 13mm (0.5") of bus wire.

Cable Take-off for BSX, RSX, HTSX, KSX, and VSX

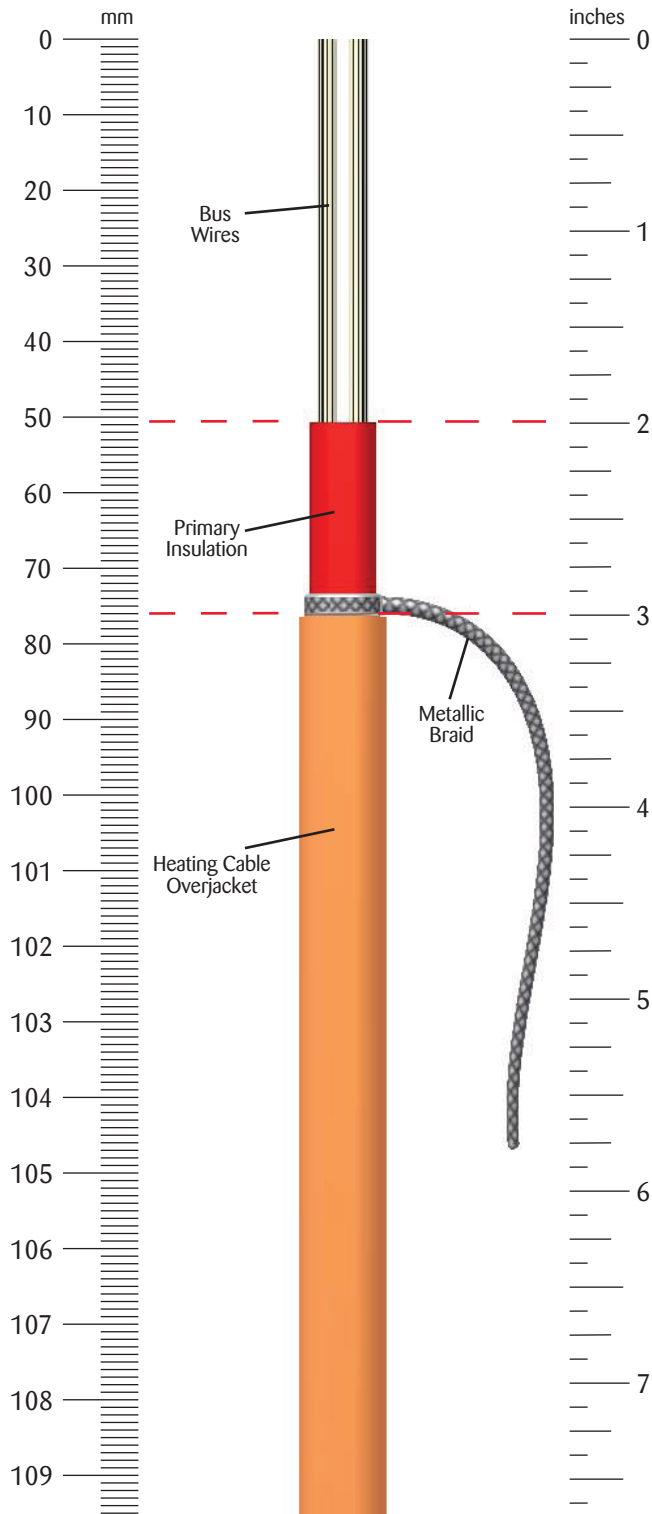

For Power Connection Boot Termination

Cable Take-off for HPT and FP

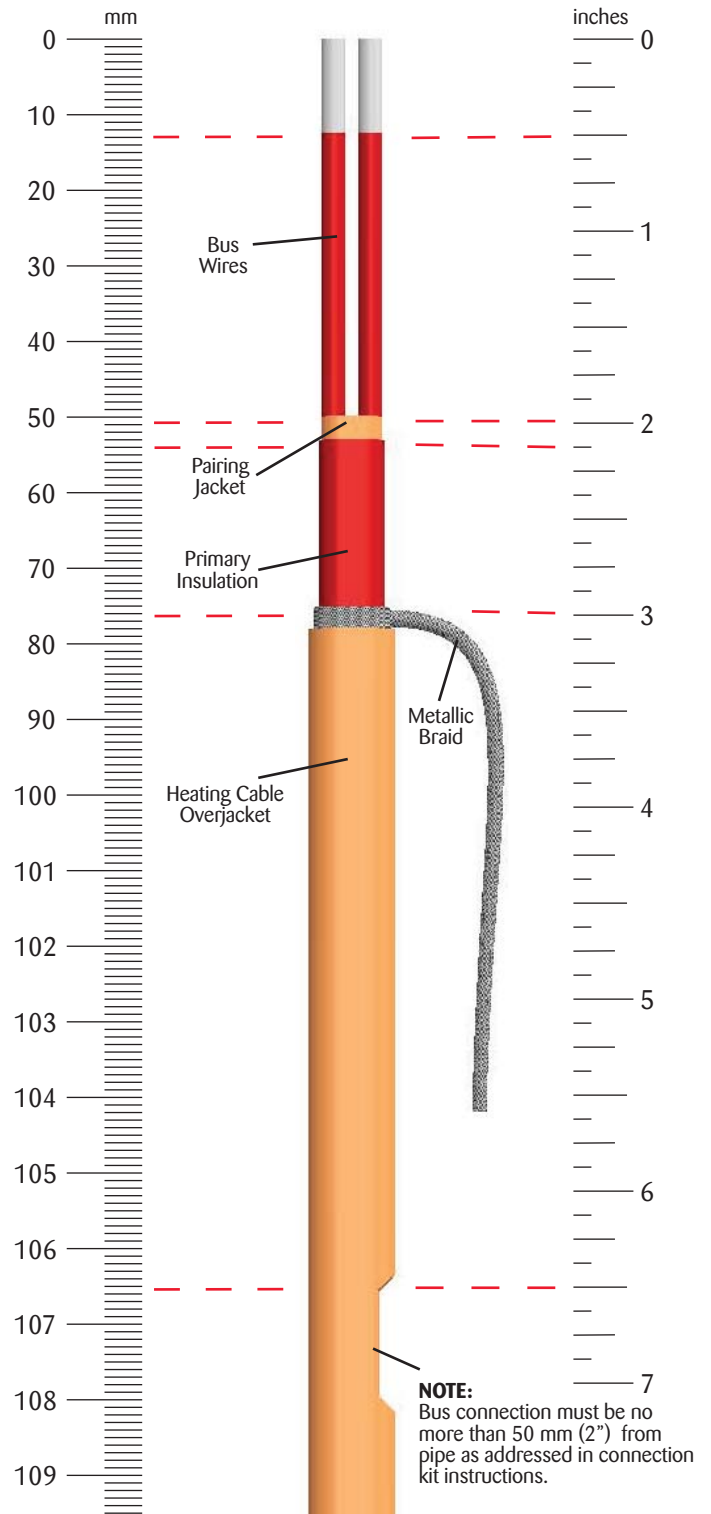

For Power Connection Boot Termination



ISO 9001
REGISTERED

THERMON . . . The Heat Tracing Specialists®

100 Thermon Dr. • PO Box 609 • San Marcos, TX 78667-0609

Phone: 512-396-5801 • Facsimile: 512-396-3627 • **1-800-820-HEAT**

www.thermon.com

In Canada call **1-800-563-8461**

Specifications and information are subject to change without notice. Form 50133-0312

For the Thermon office nearest you
visit us at . . .

www.thermon.com