

Terminator™ DP-M

Power Connection Kit for Power Connection,
In-Line Splice Connection, T-Splice Connection,
or End Termination Applications

INSTALLATION PROCEDURES



Terminator DP-M

Receiving, Storing and Handling

1. Inspect materials for damage incurred during shipping.
2. Report damages to the carrier for settlement.
3. Identify parts against the packing list to ensure the proper type and quantity has been received.

Kit Contents



Item	Quantity	Description
1	1	Expediter Assembly Support Cap with O-Ring Threaded Grommet Compressor Grommet Support Base with O-Ring
2	1	Junction Box Lid
3	1	Junction Box Base with O-Ring
4	1	Nut
5	1	Banding
6	1	Banding Guide
7	1	Terminal Blocks with DIN Rail (Refer to terminal block specifications for maximum allowable wire size)
8	1	Junction Box Cord
9	1	Terminal Block Jumper

Dimensions

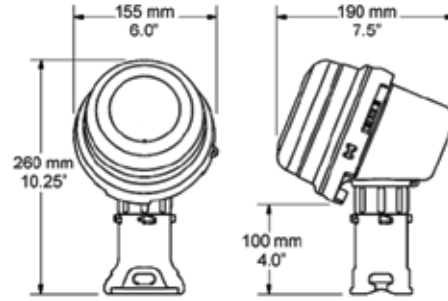

Installation Precautions

- To minimize the potential for arcing and fire caused by product damage or improper installation use ground-fault protection. The National Electrical Code (NEC) and Canadian Electrical Code (CEC) require ground-fault protection of equipment for each branch circuit supplying electric heat tracing.
- Installation must comply with Thermon requirements and be installed in accordance with the NEC, CEC, or any other applicable national and local codes.
- Component approvals and performance ratings are based on the use of Thermon specified parts only. User supplied power connection fittings must be listed or certified for intended use.
- De-energize all power sources before opening enclosure.
- Keep ends of heating cable and kit components dry before and during installation.
- Individuals installing these products are responsible for complying with all applicable safety and health guidelines. Proper personal protective equipment, or PPE, should be utilized during installation. Contact Thermon if you have any additional questions.

Certifications/Approvals



IP66/Type 4X $-60^{\circ}\text{C} \leq \text{Ta} \leq +55^{\circ}\text{C}$
Listed Heat Tracing Cable System 137M
Ordinary & Hazardous Locations
Class I, Division 2, Groups A, B, C, & D
Class II, Division 2, Groups F & G, Class III



Tools Required



INSTALLATION PROCEDURES

Cable Type	Cable Type	Cable Type
HTEK 3C60	HTEK 3C40	HTEK 2C50
HTEK 3C50	HTEK 3C30	HTEK 2C40
TEK 3C70	HTEK 2C70	HTEK 2C30
	HTEK 2C60	TEK 3C40
	TEK 3C60	TEK 3C30
	TEK 3C50	TEK 2C60
	TEK 2C70	TEK 2C50
		TEK 2C40
		TEK 2C30

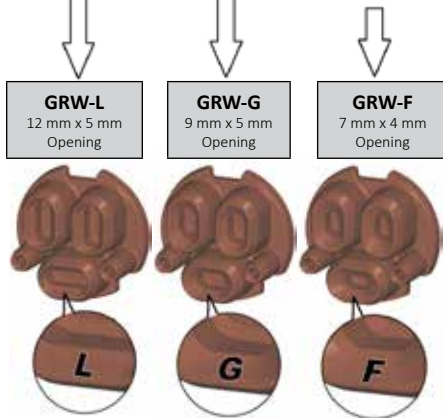

1. Select appropriate grommet for specific cable type.



2. Put together expeditor assembly. Place grommet in support base. Snap threaded grommet compressor into support base. Screw support cap onto support base.

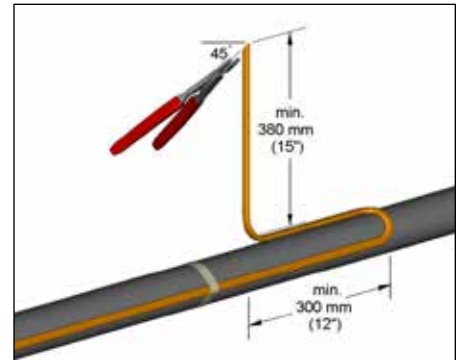

3. Cut end of cable at angle (or use screwdriver) to aid in piercing grommet. Leave additional cable for expansion loop. See page 6 for in-line splice (two cable) installation tips.



4. Insert cable into expeditor. If mounted on bottom of pipe, punch out weep hole.



5. Slide expeditor toward pipe and route cable through support base entry.



6. Insert banding guide into expeditor and snap into place.

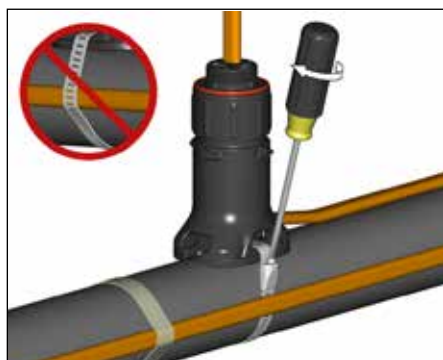

7. Mount expeditor to pipe using pipe band. Do not band over cable.

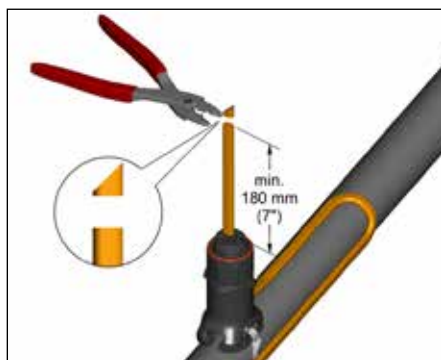

8. Cut off end of cable.



9. Cut and remove overjacket by scoring overjacket and bending cable. Do not cut metallic braid.

Terminator DP-M

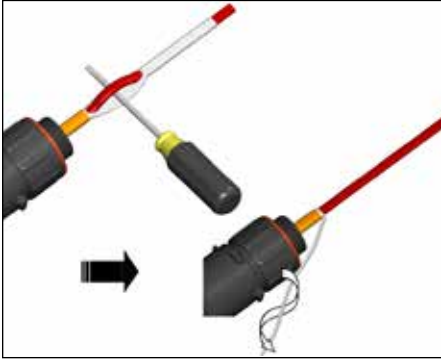

10. Separate braid strands at edge of overjacket and pull cable through opening in braid. Twist braid into a pigtail. Trim ends of braid.

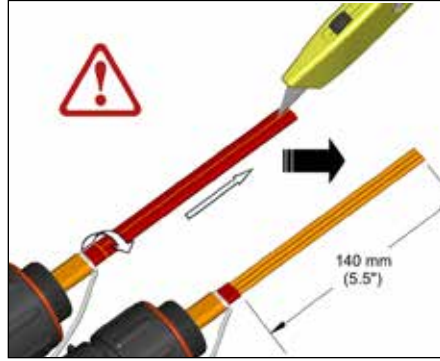

11. Cut and remove pairing jacket by scoring pairing jacket and bending cable. Do not cut insulation on conductors.

Note: Three (3) conductor cable is shown in the instructions and is representative of two (2) conductor cable installations.



12. Remove insulation and fiberglass braid (HTEK only) from ends of each conductor. Do not cut bus wire strands.

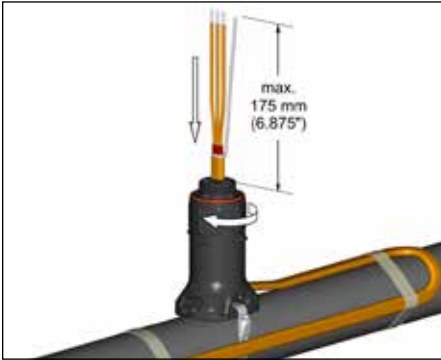

13. Push excess cable back through expediter. Tighten cap securely. Tape cable expansion loop to pipe.



14. Using dimple molded into side of junction box base to locate center of hole, drill for user supplied power connection fittings per manufacturer's recommendations (if necessary).



15. Mount junction box base on expediter. Make sure to align slots to properly orient junction box base.



16. Install power connection fittings (user supplied) and pull in power and ground wires (if necessary).

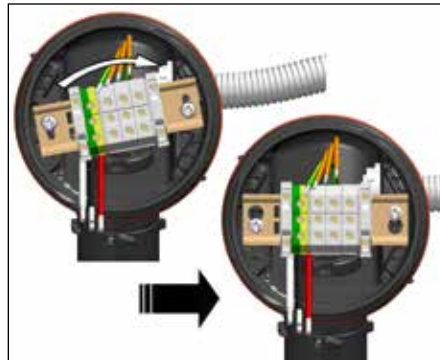

17. Install quick mount terminal blocks. Tightening torque 1.5 Nm–1.8 Nm (1.1 ft-lb–1.3 ft-lb).



18. Complete system wiring. See page 6 for wiring details for two conductor cables and three conductor cables.

INSTALLATION PROCEDURES

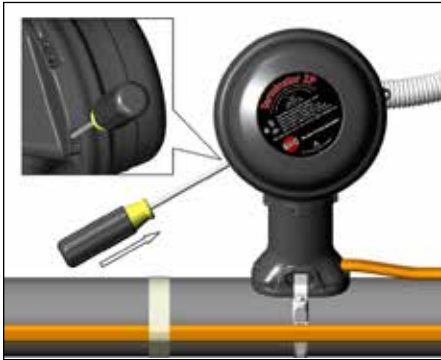

19. Install junction box lid and twist hand tight. Insert screwdriver into ratchet slots located on side of junction box base.

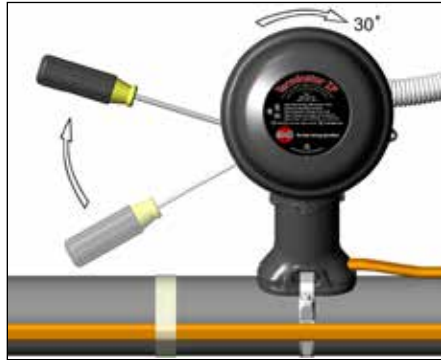

20. Use screwdriver to ratchet on junction box lid. Lid will rotate 30 degrees.

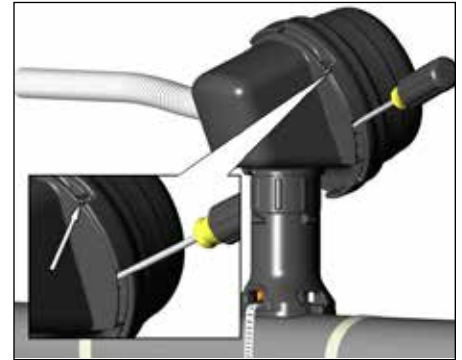

21. Lid latch mechanism fully engaged.

In-line Splice Layout Tips

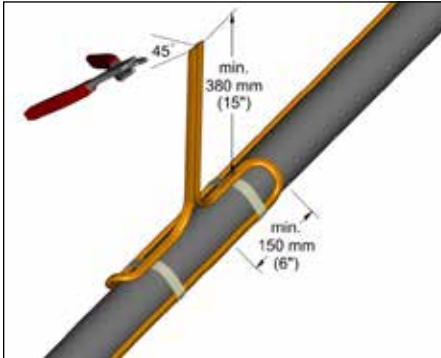

A1. Cut end of cable at angle (or use screwdriver) to aid in piercing grommet. Leave additional cable for expansion loop.

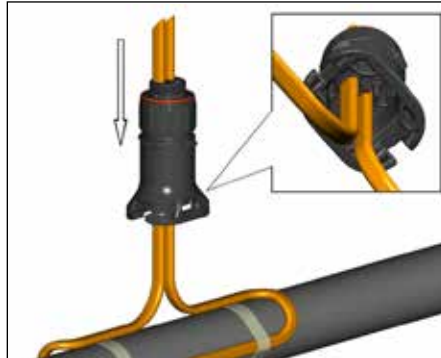

A2. Insert two cables into expediter.

Wiring Details Two Conductors

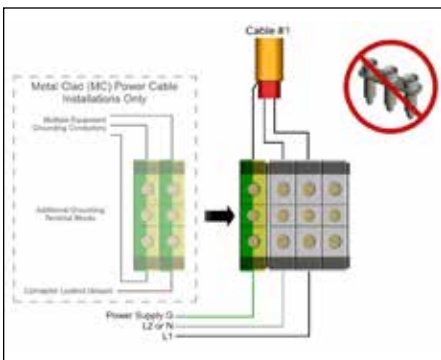

B1. Power Connection (1 Cable)

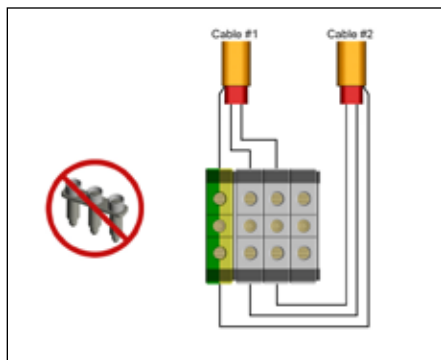

B2. In-line splice.

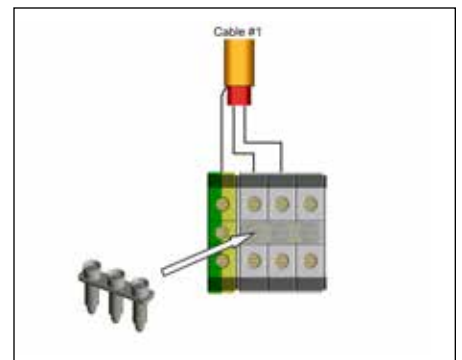

B3. End Termination (1 Cable Only). Install jumper to terminal blocks.

Terminator DP-M

Wiring Details Three Conductors

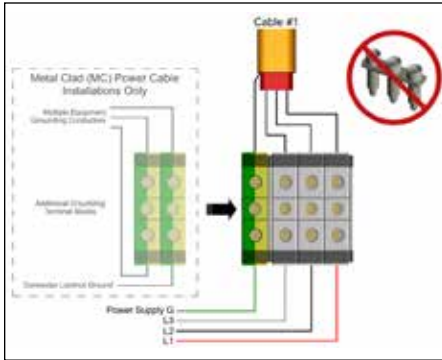

C1. Power Connection (1 Cable)

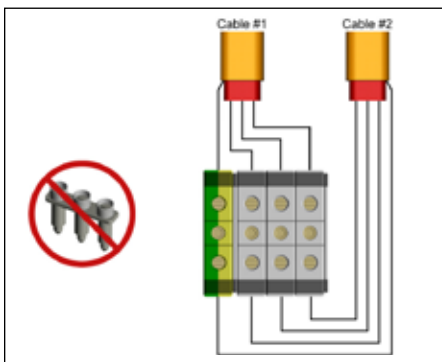

C2. In-line splice.

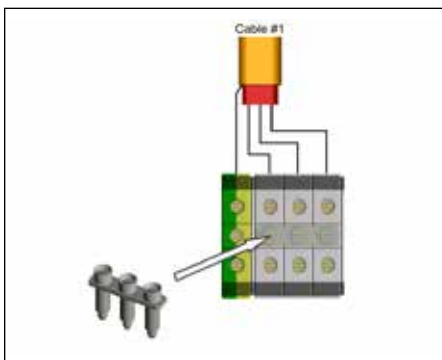

C3. End Termination (1 Cable). Install jumper to terminal blocks.

