

# FlexiPanel®

## INSTALLATION PROCEDURES

WITH MAINTENANCE AND TROUBLE SHOOTING GUIDE  
INSPECTION REPORT FORMS

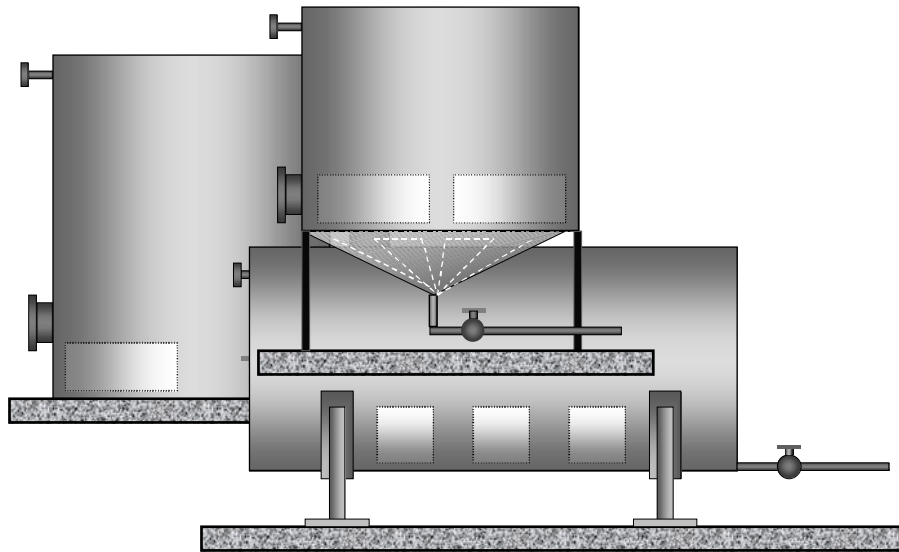

**The Heat Tracing Specialists®**

# FlexiPanel® Vessel Heating System

The following installation procedures are suggested guidelines for the installation of Thermon's FlexiPanel system. They are not intended to preclude the use of other methods and good engineering or field construction practices. A copy of this manual accompanies each heater panel shipped. It is also available on the web at [www.thermon.com](http://www.thermon.com).

## Receiving, Storing and Handling . . .

1. Inspect materials for damage incurred during shipping. Report damages to the carrier for settlement.
2. Shipping cartons are marked on the outside with the product description, sales order number and quantity. Compare information on shipping carton with packing slip and purchase order to verify receipt of correct shipment.
3. Product should be stored indoors away from standing water; however, if outdoor storage is required, a protective covering should be used.
4. Do not remove the heater from the carton until ready to install. Read all installation instructions prior to installing heater(s).

## Surface Preparation/Layout . . .

1. Surface area where the FlexiPanel is to be installed must be reasonably clean. Remove dirt, rust and scale with a wire brush and oil and grease film with a suitable solvent. Mill varnish and protective coatings may be removed with a suitable stripper.
2. FlexiPanels are typically 12" in width and vary in length up to 84". In general the heater is adhesively bonded to the lower exterior tank wall. The FlexiPanel should not extend above the vessel's normal minimum liquid level as this will result in higher operating sheath temperatures at the exposed heater area. Space FlexiPanels evenly around circumference of vertical vessels and along lower area of horizontal vessels.

## FlexiPanel Testing . . .

1. Prior to installation check each heater for proper resistance. Resistance values for standard FlexiPanel heaters are enclosed.
  - Nominal resistance is  $V^2/P$   
(Voltage squared divided by Power)  
Example -  $120V@1000\text{ Watt} = 120^2/1000$  or 14.4 ohms. The resistance window is +/- 10%. (13.0-15.8 ohms)
2. Prior to installation check each heater for insulation resistance.
  - 1000 Vdc megohmmeter check for insulation resistance between the power wires and ground wire.
  - On steel tanks repeat test between the power wires and steel tank.
  - 20 megohms minimum after 60 seconds.
3. Repeat these tests after installing heaters and after the insulation has been installed.

## FlexiPanel Attachment . . .

1. Plan for proper heater placement on the tank based on tank and heater sizes, tank obstructions, low liquid level and wiring routing requirements etc. FlexiPanels rely on good surface contact to maximize the heat transfer into the tank wall and product. Do not modify, overlap, cut or crease the heater.
2. Heaters are typically bonded to the tank wall surface using adhesive supplied with the RTM Mounting Kit Part# W3073. An instruction sheet (Thermon dwg # 54A107S1) is supplied with the kit.
3. The RTM Mounting Kit includes 2 each 10.3 oz tubes of RTV silicone sealant. One kit can install up to 8 square feet of heater. Additional tubes are available – specify Part Number W20043 Silicone Sealant 10.3oz. Allow One tube per 4 square feet of heater area. A roll of AL-20L tape is also included and installs up to 35 square feet of heater. Additional rolls of AL-20L are available - specify Part Number W400080.



Photo: RTM Mounting Kit

4. The outline of the heater is marked on the vessel using the marking pen. Load the adhesive tube into the caulking gun. Clip off end of threaded tip or puncture seal as applicable, install cartridge nozzle and cut 1/2" off the nozzle tip for proper bead size. A bead of adhesive is applied to the silicone heater layer at 2" spacing. In a similar manner apply adhesive to the marked area on the tank wall. Using the notched spreader immediately spread the adhesive on the heater and tank not exceeding 1/32". Be sure the entire surface area is covered. Position the heater in place. Do not allow the adhesive to "skin over". Compress heater firmly in place onto the tank wall using the roller. Work out any air bubbles by running the roller over the backside of the heater from the center outward. Secure the heater to the tank using aluminum tape as required. If spray on foam type insulation is to be used seal all the edges of the heater with AL-20L tape to prevent lifting. Allow 24 hours for adhesive to cure before energizing.
5. The RTM Mounting Kit includes 8 each Caution Labels to be secure to the exterior of the insulating shell to identify the tank as electrically heat traced.

# INSTALLATION PROCEDURES

## Final Connections . . .

1. FlexiPanel heaters are supplied standard with a T&B 5232 liquidtight flex conduit fitting exiting the top of the heater cap. The ½" liquidtight flexible conduit is supplied by others.
  2. Local junction boxes and thermostats are to be properly installed and supported. Connect conduit securely as required to keep enclosures dust-tight and water-tight. Area approved seal fittings when required are supplied by others.
  3. Carefully connect conduit to heater fitting without rotating the fitting. Use a wrench to keep the heater fitting from rotating while tightening . Use a wrench to keep the heater fitting from rotating. Tighten the cap nut first by hand and then with a second wrench with 25 ft-pounds of torque.
  4. Repeat heater resistance and insulation resistance tests after the heater is installed on the tank. This verifies the heater was not damaged during the heater installation. Make any corrections/repairs/replacements.
  5. Tape or bond thermostat bulb or sensor onto the tank wall mid-way between heaters and away from any heat sinks at a level similar to the heaters. If a high temperature thermostat is used to monitor maximum bulk fluid temperature the thermostat bulb or sensor would be located on the tank wall similar to the control thermostat but at a higher temperature setpoint. If a high temperature thermostat is used to monitor maximum heater sheath temperature the thermostat bulb or sensor would be located directly on the backside of one heater in the circuit and set to a temperature above the normal operating temperature of the heater.
3. An **overlimit or high temperature thermostat** may be employed in the design to monitor the maximum allowable bulk fluid temperature or maximum allowable heater temperature.
    - If designed to monitor the maximum **bulk fluid temperature** lower the setpoint of the high temperature thermostat below the actual fluid temperature to verify switch operation. The microswitch will produce an audible click sound and the heater current will be zero. Increase the setpoint to the design high temperature cutout setpoint. Note that the sensor is wall mounted and during normal operation this thermostat will always be in the closed position.
    - If designed to monitor the maximum allowable **heater temperature** lower the setpoint of the high temperature thermostat below the actual heater operating temperature to verify switch operation. The microswitch will produce an audible click sound and the heater current will be zero. Increase the setpoint to the design high temperature cutout setpoint. Note that the sensor is mounted on the heater and during normal operation this thermostat will always be in the closed position.
    - A liquid level below the heaters with the heaters energized is considered an upset condition and should be avoided or prevented unless the heating system has been specifically designed for this condition. In general the heater operating temperature is much higher without fluid to conduct heat away from the heater. Liquid level controls can be employed to cut off the power supply to the heating system during low liquid level conditions but this disables the heating system so it is best to consider the fluid level above the heaters as a system requirement for safe operation.

## Thermal Insulation . . .

1. The need for properly installed and well maintained thermal insulation cannot be overemphasized. Regardless of the type or thickness of insulation used, a protective barrier should be installed. This protects the insulation from moisture intrusion, physical damage and helps insure the proper performance of the heat tracing system. Seal around all penetrations through the thermal insulation.
2. Repeat heater resistance and insulation resistance tests after the installation of the thermal insulation and weather barrier. This verifies the heater was not damaged during the insulation installation. Make any corrections/repairs/replacements.

## System Operation . . .

1. The heating system can be energized once the fluid level is above the heaters. Turn the circuit breaker on and with the control thermostat closed (set to a temperature higher than actual fluid temperature) record the voltage and current. Retain these readings as part of an ongoing maintenance program.
  2. Lower the setpoint on the control thermostat to below the actual fluid temperature to test that the thermostat will shut off the heaters. The microswitch will produce an audible click sound and the heater current will be zero. Set the control thermostat to the desired maintain temperature setpoint.
4. The 2002 NEC requires Ground Leakage Equipment Protective Devices on all heat tracing circuits. Exception: Ground Leakage Monitoring and Alarms may prevent the need for branch EPD breakers.
  5. "Electrical Heat Tracing " caution labels should be applied to the outer surface of the weather barrier at regular intervals around the tank. 8 labels are supplied with the RTM Mounting Kit. Part# 27200 provides a package of 25 labels.
- Once the heat tracing system has been installed, an ongoing preventative maintenance program should be implemented using qualified personnel. Support documentation should be maintained which provides general information and an operating history of the specific circuits in the system.

# FlexiPanel® Vessel Heating System

## Insulation Resistance Test (IR Test)



**Description** An Insulation Resistance Test (Megger) checks the quality of the heaters insulating layers by measuring the electrical insulation resistance of the system. The higher the reading the better the insulation resistance. A low reading may indicate potential failure and allow replacement during routine maintenance. To obtain comparable results tests are done for the same duration usually 60 seconds.

Check heater insulation resistance before installation, after installation, after insulation is installed as part of an annual preventative maintenance program. Record data in a maintenance log. An IR test should also be done if any work is done on the tank insulation or if the tank has been subject to damage.

**Equipment** The test is performed with an instrument called a megohmmeter or "Megger". Thermon recommends performing the test at 1000 Vdc. 500 Vdc is the minimum acceptable test voltage.

**Testing** Tests are done with the heating equipment not connected to a power supply. On an installed system use the connections at the local junction box or splice box. Disconnect the heater lead wires from the terminals and connect to Megger.

Testing insulation layer between heater element and heater ground. Connect one lead to the heater power wires and the other lead to the heater ground wire. Set the voltage to 1000Vdc. Turn the Megger on. Apply test voltage for one minute. The minimum insulation resistance reading is 20 megohms.



If the heater is installed on a nonmetallic tank the testing is complete. To test the insulation layer between heater element and metal tank remove the negative lead from the ground wire and connect to the metal tank surface. Set the voltage to 1000Vdc. Turn the Megger on. Apply test voltage for one minute. The minimum insulation resistance reading is 20 megohms.

**Test Results** For readings below 20 megohms recheck testing procedure. Look for correct connections and settings and that the heater is isolated from other electrical connections. Check for evidence of excess moisture, corrosion or damage to the heater or wiring. Damaged heaters should be replaced.

Insulation failure can result from excessive heat or cold, dirt, moisture, oil, corrosive vapors, vibration, aging, nicked wires or mechanical or electrical damage.

FlexiPanel Cat. #	Nominal Service Voltage (VAC)	Nominal Power (Watts)	Dimensions (Inches)	Minimum -10%	Nominal Resistance	Maximum +10%
RT-521	120	500	12 x 24	25.9	28.8	31.7
RT-522	240	500	12 x 24	103.7	115.2	126.7
RT-1021	120	1000	12 x 42	13.0	14.4	15.8
RT-1022	240	1000	12 x 42	51.8	57.6	63.4
RT-2022	240	2000	12 x 84	25.9	28.8	31.7
RT Special	Up to 600V	Up to 2 W/in2	As Specified	-10%	As Specified	+10%
RTF-1236	120	300	12 x 36	43.2	48.0	52.8
RTF-1260	120	500	12 x 60	25.9	28.8	31.7
RTF-1282	120	300	12 x 84	43.2	48.0	52.8
RTF-1284	120	500	12 x 84	25.9	28.8	31.7
RTF-2260	240	500	12 x 60	103.7	115.2	126.7
RTF-2284	240	500	12 x 84	103.7	115.2	126.7
RTF Special	Up to 600V	Up to 0.7 W/in2	As Specified	-10%	As Specified	+10%
FlexiPanel Cat. #	Nominal Service Voltage (VAC)	Nominal Power (Watts)	Dimensions (Inches)	Minimum -10%	Nominal Resistance	Maximum +10%

# WIRING SCHEMATICS

## Single Heater / Phase to Phase or Phase to Neutral

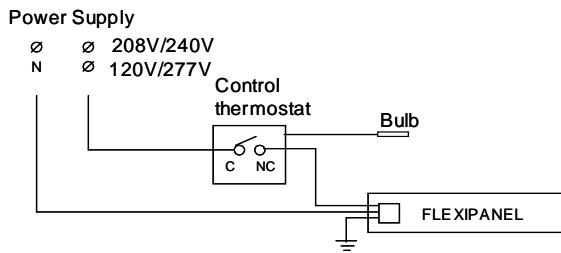

## Multiple Heater / Phase to Phase or Phase to Neutral

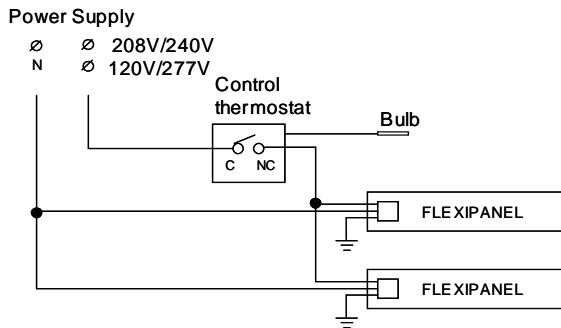

## Multiple Heater / Contactor / Phase to Phase Heaters / Phase to Neutral Control

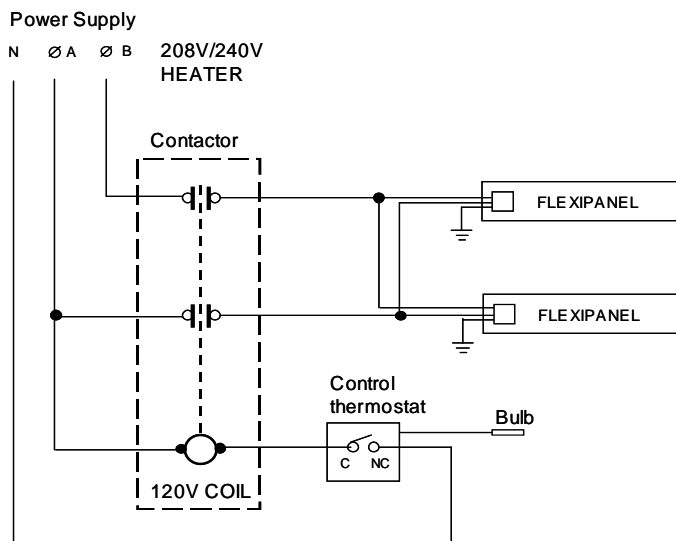

## Sample Circuit - Control Thermostat and High Temperature Cutout Thermostat

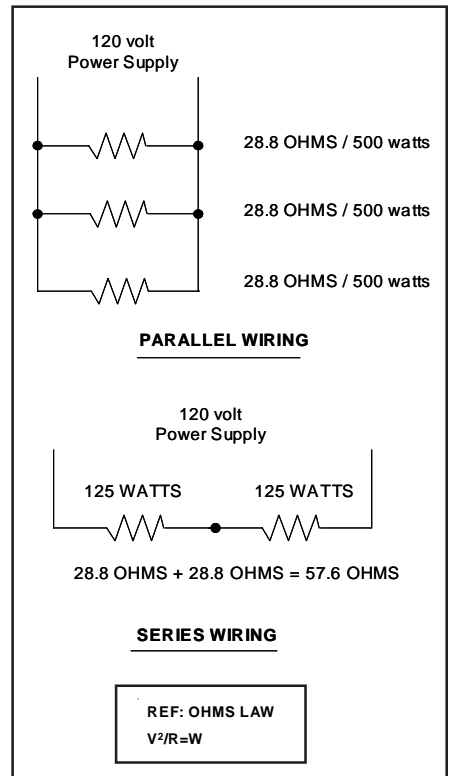
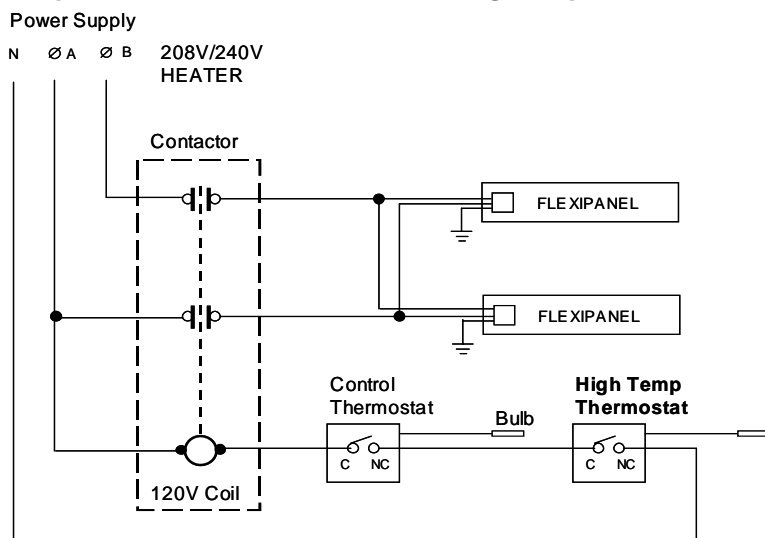

The Heat Tracing Specialists®

# FlexiPanel<sup>®</sup> Vessel Heating System

## Maintenance and Troubleshooting Guide

The following information is intended to assist you in maintaining and troubleshooting electric tank and vessel heating systems. The primary objective is to enhance your understanding of the elements of a successful heat tracing installation. Of these elements, one of the most important is thermal insulation.

Before calling your heat-tracing vendor make a visual inspection of the installation; perhaps the thermal insulation is wet, damaged or missing. Also, consider that repairs or maintenance of in-line or nearby equipment may have resulted in damage to the heating equipment. These are common causes of heat tracing problems, and they are often overlooked. Other possible causes are listed below with their symptoms and remedies.

Note: If you suspect that an electric heating circuit is damaged, we recommend a dielectric insulation resistance (megger) test be performed with a 1000 Vdc megohmmeter. See page 4 of this manual. Readings can be logged on Part 2 of the Thermon “Inspection Report Form” brochure. Periodic testing with accurate records will establish a “normal” range of operation, and dielectric insulation resistance readings, which deviate from the normal range, can quickly reveal a damaged circuit.

### Thermal Insulation . . . An Integral Part of Every Heat Tracing System

The value of properly installed and well-maintained thermal insulation cannot be overemphasized. Without the insulation, the heat losses are generally too high to be offset by a conventional heat tracing system.

Before the thermal insulation is installed on the tank or vessel, the heating circuit should be tested for dielectric insulation resistance. This will ensure that the heater has not been damaged while exposed on the uninsulated tank.

There are many different tank insulation materials, each of which has advantages in particular applications. The temperature ratings of some of the common insulation materials are listed below in order of their efficiency (from the most to least effective), based on equivalent thicknesses:

Polyurethane foam (180°F - 250°F)	– Rigid
Fiberglass (375°F – 500°F)	– Flexible
Cellular Glass (400°F)	– Rigid
Calcium Silicate (1200°F+)	– Rigid

Regardless of the type or thickness of insulation used, a protective barrier should be installed. This protects the insulation from moisture intrusion and physical damage, and helps ensure the proper performance of the heat tracing system. Insulating materials such as fiberglass and calcium silicate are very susceptible to water absorption, which dramatically increases the heat lost. They should be replaced if they become wet.

### SYMPTOM

#### I. No heat/No current

##### POSSIBLE CAUSE

A. Loss of Power (Voltage)

B. Controller set point too low

C. High-temperature limit switch activated

D. “Open” series heating circuit

E. Controller Failure

##### REMEDY

Restore power to the heating circuit. (Check circuit breaker and electrical connections.)

Adjust set point.

May require manual reset to re-enable heating circuit. Check set point. (Identify cause of high temperature- review design, check liquid level.)

Repair or replace circuit.<sup>1</sup>

Repair sensor or controller.<sup>2</sup>

### SYMPTOM

#### II. Low System Temperature

##### POSSIBLE CAUSE

A. Controller Set Point Too Low

B. Temperature sensor located too close to heater or other heat source; may be accompanied by excessive cycling of control relays/contacts.

C. Insulation material and/or thickness different than designed.

D. Ambient temperature lower than designed

E. Lower Voltage (Check at power Connection point)

F. Liquid Level below heaters (Heaters cycling or deenergized if tied into LLL switch)

##### REMEDY

Adjust set point.

Relocate sensor.

Replace insulation; Increase insulation thickness (if dry); Consider increasing voltage<sup>3</sup> for higher heater output; Add additional heaters.

Add additional heaters; Consider increasing voltage<sup>3</sup>; Add additional insulation.

Adjust voltage<sup>3</sup> to meet design requirements.

Increase liquid level; Lower heater location below low liquid level.



# MAINTENANCE AND TROUBLESHOOTING GUIDE

## SYMPTOM

### III. High System Temperature

#### POSSIBLE CAUSE

#### REMEDY

- |  |   |
|--|---|
| A. Controller ‘on’ continuously                        | Adjust set-point or replace sensor. <sup>2</sup>                      |
| B. Controller failed with contacts closed              | Replace sensor or controller. <sup>2</sup>                            |
| C. Sensor located near heat sink.                      | Relocate sensor to an area representative of overall tank conditions. |
| D. Backup heating circuit controller “on” continuously | Adjust set-point or replace backup controller.                        |

## SYMPTOM

### IV. Excessive Cycling

#### POSSIBLE CAUSE

#### REMEDY

- |   |   |
|---|---|
| A. Temperature sensor located too close to heater or other heat source; may be accompanied by low system temperature. | Relocate sensor.  |
| B. Connected voltage too high (See item C)  | Lower voltage <sup>4</sup>  |
| C. Heater output too high   | Install lower-output heater or lower voltage.   |
| D. Fluid level below heater   | Increase fluid level above heaters. <sup>5</sup>  |
| E. Wall thickness larger than design allowance (Not an issue for steel wall)  | Lower maintain temperature; Lower voltage; Design for lower watt density heater; Increase setpoint for high temp cut out. |

## Footnotes . . .

- 1 FlexiPanel heaters must usually be replaced if defect not found in heater wires . Note: FlexiPanel heaters may use an internal thermal cutout that will result in a “open” circuit if activated due to temperatures above the rated set point. This may be normal. Check system design.
- 2 Mechanical thermostat sensors cannot be repaired or replaced; RTD or thermocouple sensors may be replaced. Some controllers have replaceable contacts/relays, or may require a manual reset if a “trip-off” condition on the heating circuit was detected.
- 3 The operation of most electric heating circuits is dramatically affected by changes in the supply voltage. Before making any changes, consult the heater manufacturer with information on the alternate voltages available, otherwise, heater failure and/or electrical safety hazard may result in some situations.
- 4 Verify voltage prior to energizing heating system. Higher voltages can result in heater failure and/or an electrical safety hazard may result in some situations.
- 5 A liquid level below the heaters is considered an upset condition and should be avoided or prevented unless the heating system has been specifically designed for this condition.

# FlexiPanel® Vessel Heating System

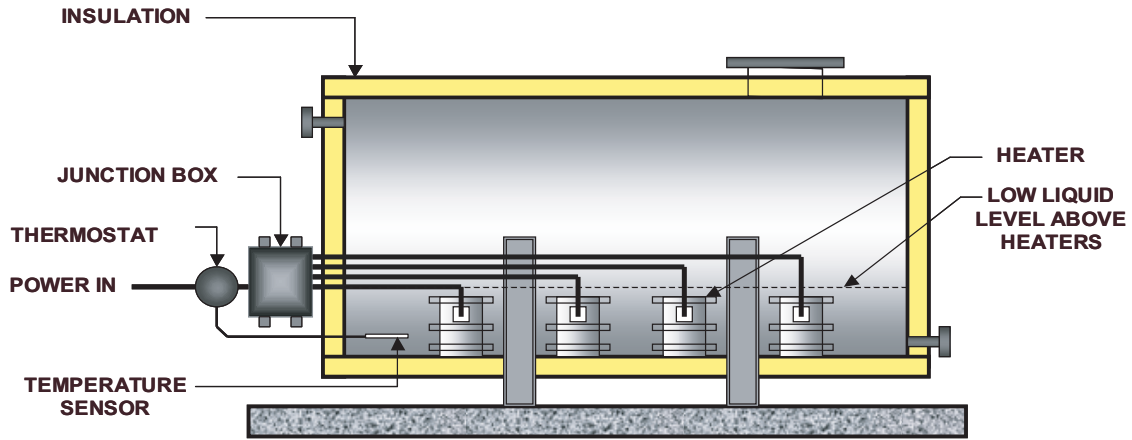

SAMPLE INSTALLATION – HORIZONTAL TANK

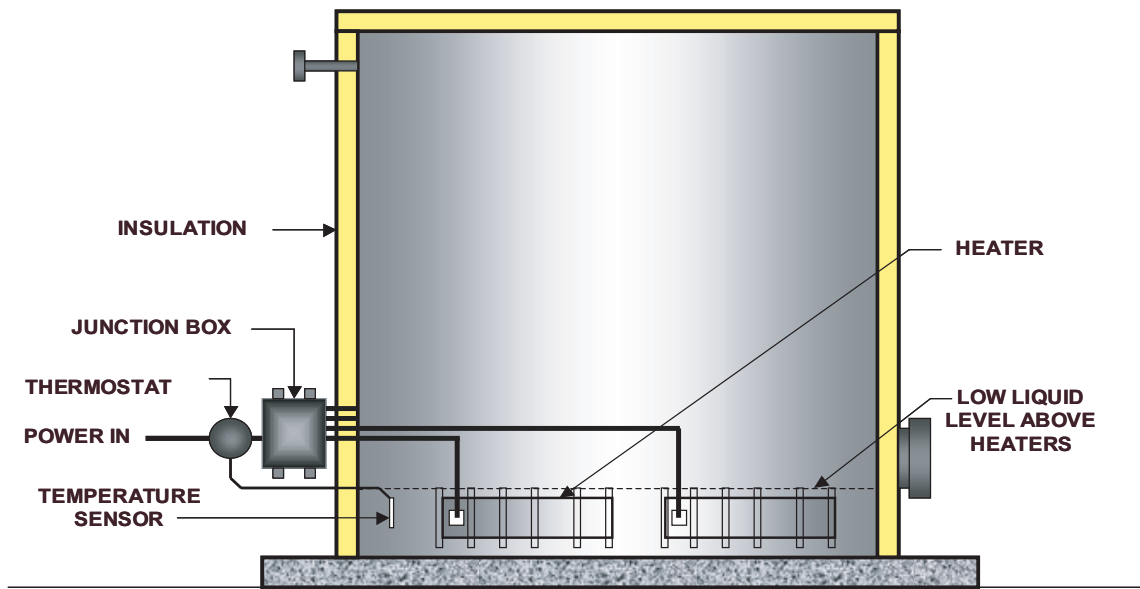

SAMPLE INSTALLATION – VERTICAL TANK



THERMON . . . The Heat Tracing Specialists®

ISO 9001  
REGISTERED

100 Thermon Dr. PO Box 609 San Marcos, TX 78667-0609  
 Phone: 512-396-5801 Facsimile: 512-396-3627 800-820-HEAT  
 www.thermon.com In Canada call 800-563-8461



# FlexiPanel<sup>®</sup> Vessel Heating System

## Inspection Report Form For Electric Tank Heating Part 1

Page \_\_\_\_ of \_\_\_\_

LOCATION	SYSTEM	REFERENCE DRAWING(S)

CIRCUIT INFORMATION						
BKR PANEL NO.						
BKR POLE(S) NO.						
HEATER JUNCTION BOX #						
# HEATERS PER JUNCTION BOX						
HEATER CONTROLLER						
HIGH LIMIT CONTROLLER (IF ANY)						
GROUND FAULT PROTECTION (TYPE)						
GROUND FAULT TRIP SETTING						

DATE	COMMENTS AND ACTIONS

# INSPECTION REPORT FORMS

## Inspection Report Form For Electric Tank Heating Part 2

Page \_\_\_\_ of \_\_\_\_

<b>QUANTITY/TYPE/LOCATION/RESISTANCE</b>						
HEATER MODEL						
PART NUMBER						
LOCATION						
RESISTANCE						

<b>INSULATION RESISTANCE TESTING (BEFORE INSULATING)</b>						
HEATER #						
TEST VOLTAGE						
MEGGER VALUE						

<b>INSULATION RESISTANCE TESTING (AFTER INSULATING)</b>						
HEATER #						
TEST VOLTAGE						
MEGGER VALUE						

<b>HEATER SUPPLY VOLTAGE</b>						
VALUE AT POWER SOURCE						
VALUE AT FIELD CONNECTION						

<b>HEATER CIRCUIT CURRENT READING</b>						
AMP READING						
GROUND FAULT CURRENT						

# FlexiPanel<sup>®</sup> Vessel Heating System

## Inspection Report Form For Electric Tank Heating Part 3

Page \_\_\_\_\_ of \_\_\_\_\_

<b>THERMAL INSULATION</b>						
DAMAGED INSULATION OR LAGGING						
WEATHER SEAL GOOD						
INSULATION OR						
LAGGING MISSING						
PRESENCE OF MOISTURE						
CAUTION LABELS INSTALLED						

<b>HEATING SYSTEM COMPONENTS</b>						
ENCLOSURES, BOXES SEALED						
SIGN OF CORROSION						
HEATER WIRE CONNECTIONS						
PRESENCE OF MOISTURE						

<b>HEATING AND/OR HIGH LIMIT CONTROLLER</b>						
MODEL						
CONTROLLER SET POINT(S)						
OPERATING PROPERLY						

<b>PERFORMED BY</b>	<b>COMPANY</b>
<b>DATE</b>	
<b>APPROVED BY</b>	<b>COMPANY</b>
<b>DATE</b>	

